

### MEASUREMENT RANGE

300 -7500 mm

- ✓ Time-Of-Flight (TOF)
- ✓ Integrated lightning
- ✓ QVGA Resolution
- ✓ Integrated image processing



|                |                     |
|----------------|---------------------|
| Part Number    | 600-100-207         |
| Part Reference | CAM-3TIQC-C99S-SF-A |



| OPTICAL DATA                       |                                | INTERFACE          |                                |
|------------------------------------|--------------------------------|--------------------|--------------------------------|
| Technology                         | 3D Time-of-Flight              | Wi-Fi access point | 802.11 b/g/n 2.4GHz            |
| Measurement range short range mode | 300...3750mm <sup>1</sup>      | Push Button        | Enable local Wi-Fi network     |
| Measurement range long range mode  | 300...7500mm <sup>1</sup>      | Indicator LED's    | 2x multicolour + 2 color Fix   |
| Image Resolution                   | QVGA (320x240 px)              | POWER Connector    | Power supply, IO-Link, SIO     |
| Angle of aperture                  | 37° x 27.9° (Diag 46.1°)       | Ethernet Connector | Fast Ethernet (100 Mbps)       |
| Light source                       | Laser class 1, infrared 850 nm | Configuration      | Rest API on Wi-Fi and Ethernet |

<sup>(1)</sup>Operating range depends of the infrared reflectivity of the target object

| ELECTRICAL DATA                        |                           | MECHANICAL DATA               |                                  |
|--|---------------------------|-------------------------------|----------------------------------|
| Supply voltage range (U <sub>B</sub> ) | 18..30 VDC                | Dimensions                    | 92 x 92 x 81 mm                  |
| Power Consumption (no-load)            | < 1A                      | Enclosure rating              | IP65, IP67                       |
| Number of digital outputs              | 2, PIN 4 & 2              | Ambient temperature operation | 0...+50 °C                       |
| Number of digital inputs               | 1, PIN 5 (Trigger signal) | Shock and vibration           | IEC 60947-5-2                    |
| Outputs Polarity                       | PNP/NPN Configurable      | Weight                        | 470g                             |
| Outputs Current PIN 4                  | < 200 mA                  | Housing material              | Aluminium, PC, PA                |
| Outputs Current PIN 2                  | < 600 mA                  | Window material               | PMMA                             |
| Voltage Drop Digital Outputs           | < 100 VDC                 | POWER connector               | Male M12-5 PIN A-coded           |
| Short-circuit protection               | Yes                       | Ethernet connector            | Female M12-4 PIN D-coded         |
| Voltage reversal protection            | Yes                       | Mounting                      | 8x M4 (4x on two opposite sides) |
| Max cable length                       | ≤ 20 m                    |                               |                                  |

## MECHANICAL DRAWINGS

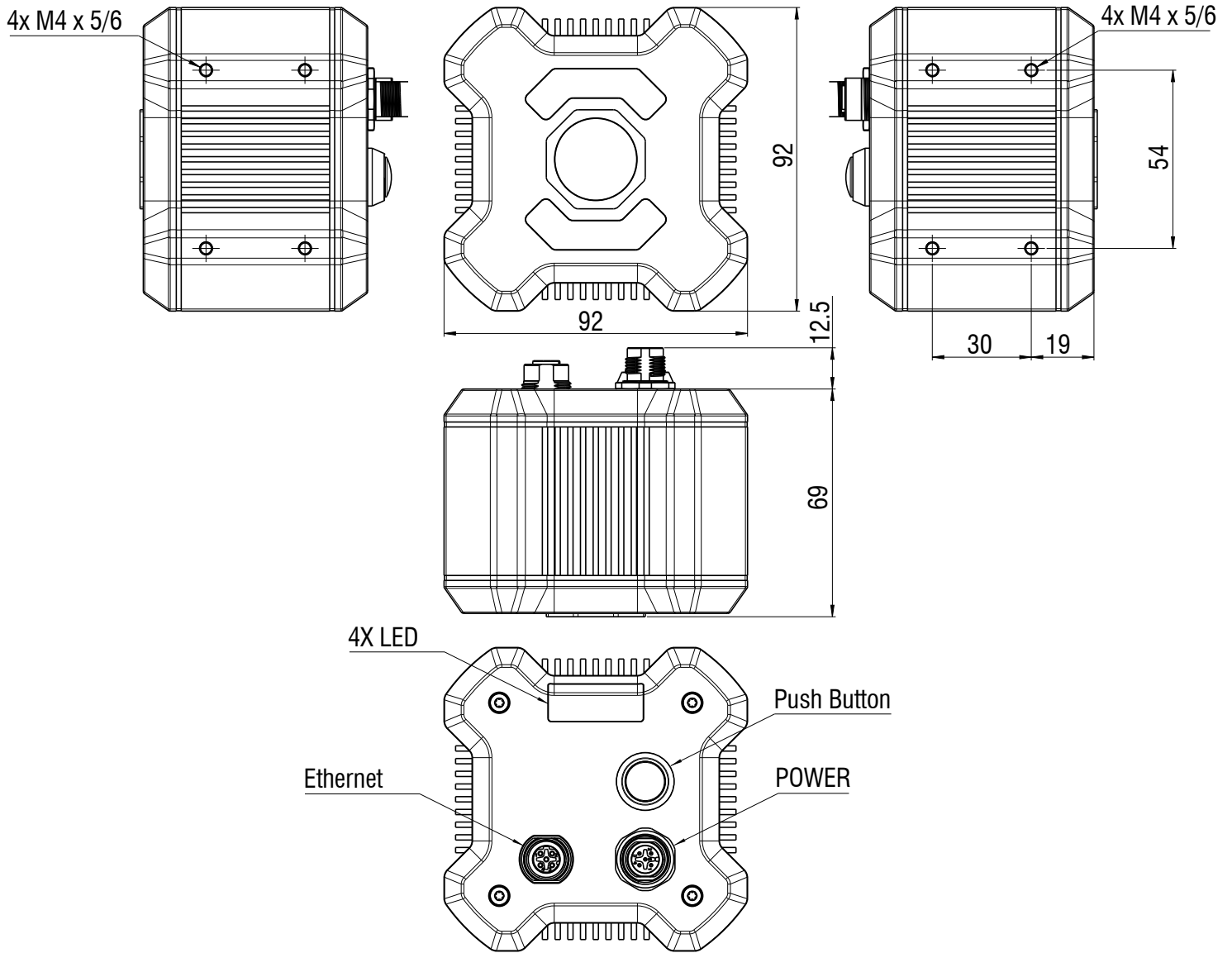

### MOUNTING CONDITIONS

|                           |      |
|---------------------------|------|
| Max Tightening torque     | 4 Nm |
| M4 mounting Thread length | 5 mm |

### FIELD OF VIEW



| Installation Distance (m) | X (m) | Y (m) |
|---------------------------|-------|-------|
| 0.5                       | 0.33  | 0.25  |
| 1                         | 0.67  | 0.5   |
| 2                         | 1.34  | 1     |
| 3                         | 2.01  | 1.51  |
| 3.5                       | 2.34  | 1.76  |
| 7.5                       | 5.02  | 3.76  |

## POWER CONNECTOR

Male M12-5 PIN A-coded

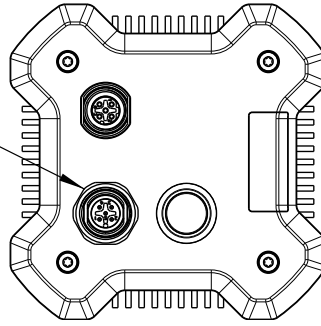

### WIRING DIAGRAM

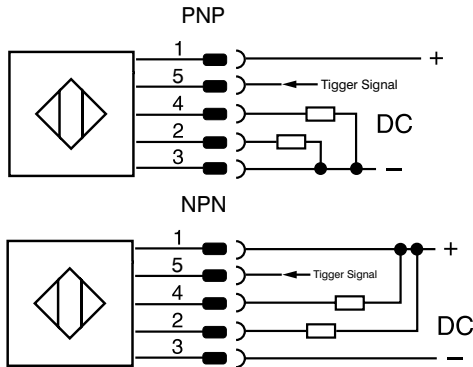

### PIN ASSIGNMENT

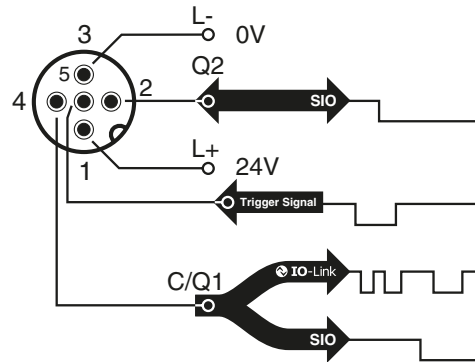

### IO-LINK FUNCTIONALITIES

| IO-LINK CHARACTERISTICS      | VALUE FOR CAM-3TIQC-C99S-Sx-A |
|------------------------------|-------------------------------|
| Vendor ID                    | 342 (0156 hex)                |
| Device ID                    | 13762817 (D20101 hex)         |
| IO-Link Version              | 1.1                           |
| Bit rate                     | 230,4 kbit/s (COM3)           |
| Minimum Cycle Time           | 8000 ms                       |
| Supports SIO Mode            | YES                           |
| Supports Data Storage        | YES                           |
| Supports Block Configuration | YES                           |
| Supports ISDU                | YES                           |
| Process Data Input Width     | 32 Bytes                      |
| Process Data Output Width    | 16 Bytes                      |

IODD files may be downloaded from [www.contrinex.com](http://www.contrinex.com) (Download section)

## ETHERNET CONNECTOR

### PIN ASSIGNMENT

Female M12-4 PIN d-coded, fast Ethernet

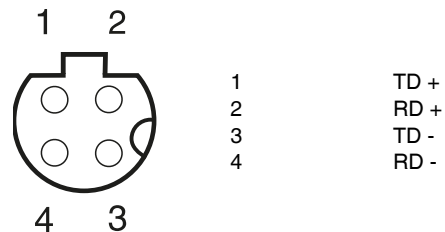
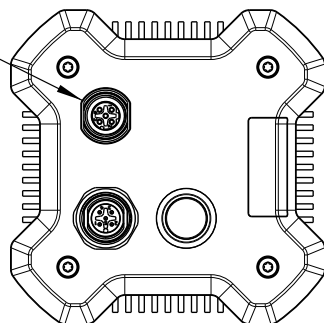

Operators of the products we supply are responsible for compliance with measures for the protection of persons. The use of our equipment in applications where the safety of persons might be at risk is only authorized if the operator observes and implements separate, appropriate and necessary measures for the protection of persons and machines. Terms of delivery and rights to change design reserved.

## CAMERA CONFIGURATION WITH SMARTVISION APP

The Contrinex Smart 3D Camera is configured using the **Contrinex SmartVision App/Software**, available for download on iOS, Android, and Windows platforms.

The camera operates using selectable **Use Cases**, which are pre-defined processing functions combining optimized 3D algorithms for specific industrial tasks. Each Use Case requires application-specific configuration by the user, including the teaching of reference scenes and the definition of evaluation parameters.

**Configuration is performed through an intuitive guided workflow in the SmartVision App, allowing the user to:**

- Select the appropriate Use Case for the application

- Define Regions of Interest (ROI) and thresholds
- Teach background or reference scenes
- Configure output behavior (SIO, IO-Link, REST API)
- Adjust exposure, acquisition parameters, and measurement settings
- Save and manage multiple Use Case configurations in the device

Up to **64 Use Cases** can be stored in the device, **with one active Use Case at a time.**

For detailed configuration and commissioning instructions, refer to the Operating Manual.

### AVAILABLE USE CASES

The Contrinex Smart 3D Camera provides three embedded Use Cases that execute 3D data processing directly on the device. Each Use Case applies optimized algorithms for a specific industrial task and delivers results via SIO, IO-Link, or Ethernet (REST API).

Only **one Use Case** at a time can be linked to the SIO outputs/IO-Link; up to **64 Use Cases** can be stored in the device.

The Selection of the active use case can be performed through the SmartVision app, the IO-Link process data outputs or the Rest API over Ethernet.

### DISTANCE MEASUREMENT

3D distance evaluation within user-defined Regions of Interest (ROI).

#### Functionality

- Measures absolute distance values (Average, Max, Min)
- Measurement relative to background or camera origin
- Up to 64 configurable ROIs
- Output via IO-Link Process Data or REST API

#### Typical values

Target Object surface: 200 x 200 mm

Target Reflectivity: 18%

| Operating Distance in m | Repeatability mm |
|-------------------------|------------------|
| 0.3 ..3                 | 5                |
| 3..5                    | 15               |
| 5..7.5                  | 30               |

### OBJECT SIZING

#### Functionality

##### Measures:

- Longest side (X)
- Smallest side (Y)
- Average Height (Z)
- Max height (Max Z)
- Angle (°), From Image horizontal

Data output via IO-Link Process Data, or REST API

##### Limitation:

- Full object within the field of view
- Flat Background
- Static target object
- Minimum Object size: 100 x 100 x 100 mm
- Operating range 0.3 to 3.75 m

#### Typical values

Target Object surface: 200 x 200 mm

Target Reflectivity: 18%

Exposure time: 8 ms

Background Distance: 1m

| Metric                        | Performance |
|-------------------------------|-------------|
| Repeatability (L, W, H)       | 5 mm        |
| Accuracy (Length, Width)      | ± 25 mm     |
| Accuracy Height (flat object) | ± 25 mm     |

## COMPLETENESS CHECK

Verification of the presence of all required items in **compartmentalized packaging** (trays, blister packs, kitting boxes, sorting grids, etc.). This Use Case is designed for applications where **all inspected objects are identical in shape and dimensions**.

### Functionality

- Detects whether each compartment contains an object
- Confirms the presence of uniform, identical items across all compartments
- Identifies missing, misplaced, or incorrectly seated items
- Evaluates completeness of multi-slot packaging in a single acquisition
- Provides a Boolean pass/fail output
- Results available via SIO, IO-Link Process Data, or REST API
- Ideal for kitting, blister packaging, multi-slot assembly trays, and order verification

### Limitations

- All inspected objects must be identical (size, shape, and overall geometry)
- Compartments must be fully visible in the camera's field of view
- Transparent or highly reflective tray materials may affect stability
- Very dark or low-reflective objects can reduce detection reliability
- Excessive packaging tilt may distort compartment geometry

### Typical Target object requirements:

Distance to object 1m.

- Maximum target object speed: 0.2ms
- Minimum container height for automatic alignment: 30 mm
- Maximum angular variation\*:  $\pm 45^\circ$
- Minimum detectable item size inside packaging compartments:  $20 \times 20 \times 60$  mm

\*Angular deviation relative to the taught reference image (2D plane).

# IO-LINK PROCESS DATA REPRESENTATION

## PROCESS DATA INPUT

### BITOFFSET

| Byte | 7                            | 6       | 5        | 4       | 3       | 2       | 1        | 0        |
|------|------------------------------|---------|----------|---------|---------|---------|----------|----------|
| 31   |                              | Error   | Ethernet | WI-FI   | Trigger | Ready   | Output 2 | Output 1 |
| 30   | Running Config ID (0 to 255) |         |          |         |         |         |          |          |
| 29   | Bool 8                       | Bool 7  | Bool 6   | Bool 5  | Bool 4  | Bool 3  | Bool 2   | Bool 1   |
| 28   | Bool 16                      | Bool 15 | Bool 14  | Bool 13 | Bool 12 | Bool 11 | Bool 10  | Bool 9   |
| 27   | Measurement value 1          |         |          |         |         |         |          |          |
| 26   | Measurement value 2          |         |          |         |         |         |          |          |
| 25   | Measurement value 3          |         |          |         |         |         |          |          |
| 24   | Measurement value 4          |         |          |         |         |         |          |          |
| 23   | Measurement value 5          |         |          |         |         |         |          |          |
| 22   | Measurement value 6          |         |          |         |         |         |          |          |
| 21   | Measurement value 7          |         |          |         |         |         |          |          |
| 20   | Measurement value 8          |         |          |         |         |         |          |          |
| 19   | Measurement value 9          |         |          |         |         |         |          |          |
| 18   | Measurement value 10         |         |          |         |         |         |          |          |
| 17   | Measurement value 11         |         |          |         |         |         |          |          |
| 16   | Measurement value 12         |         |          |         |         |         |          |          |
| 15   | Measurement value 13         |         |          |         |         |         |          |          |
| 14   | Measurement value 14         |         |          |         |         |         |          |          |
| 13   | Measurement value 15         |         |          |         |         |         |          |          |
| 12   | Measurement value 16         |         |          |         |         |         |          |          |
| 11   | Measurement value 17         |         |          |         |         |         |          |          |
| 10   | Measurement value 18         |         |          |         |         |         |          |          |
| 9    | Measurement value 19         |         |          |         |         |         |          |          |
| 8    | Measurement value 20         |         |          |         |         |         |          |          |
| 7    | Measurement value 21         |         |          |         |         |         |          |          |
| 6    | Measurement value 22         |         |          |         |         |         |          |          |
| 5    | Measurement value 23         |         |          |         |         |         |          |          |
| 4    | Measurement value 24         |         |          |         |         |         |          |          |
| 3    | Measurement value 25         |         |          |         |         |         |          |          |
| 2    | Measurement value 26         |         |          |         |         |         |          |          |
| 1    | Measurement value 27         |         |          |         |         |         |          |          |
| 0    | Measurement value 28         |         |          |         |         |         |          |          |

|                          |  |
|--------------------------|--|
| <b>Output 1</b>          | 0 : Output 1 Signal is ON<br>1 : Output 1 Signal is OFF  |
| <b>Output 2</b>          | 0 : Output 2 Signal is ON<br>1 : Output 2 Signal is OFF  |
| <b>Ready</b>             | 0 : Image Acquisition or treatment is ongoing<br>1 : Camera is ready for new acquisition             |
| <b>Trigger</b>           | 0 : Physical Input trigger signal is OFF<br>1 : Physical Input trigger signal is ON                  |
| <b>WI-FI</b>             | 0: Local WI-FI network is turned OFF<br>1: Local WI-FI network is turned ON                          |
| <b>Ethernet</b>          | 0 : no Ethernet link signal detected<br>1 : Ethernet link signal detected                            |
| <b>Error</b>             | 0 : Camera has no error<br>1 : Camera has error  |
| <b>Running Config ID</b> | 0 to 63 : ID of active configuration in the camera<br>255 : Selected Configuration ID does not exist |
| <b>Bool 1-16</b>         | 0 : Boolean Result of Configuration is False<br>1 : Boolean Result of active configuration is TRUE   |

# IO-LINK PROCESS DATA REPRESENTATION

## PROCESS DATA OUTPUT

### BITOFFSET

|                                 | 7   | 6 | 5 | 4 | 3 | 2 | 1 | 0       |
|---------------------------------|---|---|---|---|---|---|---|---------|
| <b>15</b>                       | RFU   |   |   |   |   |   |   | Trigger |
| <b>14</b>                       | Running Config ID (0 to 255)  |   |   |   |   |   |   |         |
| <b>13..0</b>                    | RFU   |   |   |   |   |   |   |         |
| <b>Trigger</b>                  | 0 : NO new Image aquisition is requested<br>1 : New Image aquisition is requested   |   |   |   |   |   |   |         |
| <b>Running Configuration ID</b> | 0 to 63 : Selection ID of active configuration in the camera<br>64 to 255 : Not available for selection (Generates Error) |   |   |   |   |   |   |         |
| <b>RFU</b>                      | Reserved for future use   |   |   |   |   |   |   |         |

## IO-LINK SERVICE DATA

| PARAMETER NAME           | INDEX |      | SUB INDEX |      | SIZE<br>(BYTES) | ACCES | DATA<br>TYPE            | DATA<br>STORAGE | DEFAULT VALUE                       | RANGE  |
|--------------------------|-------|------|-----------|------|-----------------|-------|-------------------------|-----------------|-------------------------------------|--|
|                          | dec   | hex  | dec       | hex  |                 |       |                         |                 |                                     |  |
| <b>DIRECT PARAMETER</b>  |       |      |           |      |                 |       |                         |                 |                                     |  |
| Master-Command           | 0     | 0x00 | 1         | 0x01 | 1               | W     | uint8                   |                 | -                                   | -  |
| MasterCycle-Time         |       |      | 2         | 0x02 | 1               | R/W   | uint8                   |                 | 0x44 (8ms)                          | -  |
| MinCycleTime             |       |      | 3         | 0x03 | 1               | R     | uint8                   |                 | 0x44 (8ms)                          | -  |
| M-Sequence-Capability    |       |      | 4         | 0x04 | 1               | R     | uint8                   |                 | 0x39                                | -  |
| Revision ID              |       |      | 5         | 0x05 | 1               | R     | uint8                   |                 | 0x11                                | -  |
| ProcessDataIn            |       |      | 6         | 0x06 | 1               | R     | uint8                   |                 | 0xDF                                | -  |
| ProcessDataOut           |       |      | 7         | 0x07 | 1               | R     | uint8                   |                 | 0x8F                                | -  |
| VendorID 1               |       |      | 8         | 0x08 | 1               | R     | uint8                   |                 | 0x01                                | -  |
| VendorID 2               |       |      | 9         | 0x09 | 1               | R     | uint8                   |                 | 0x56                                | -  |
| DeviceID 1               |       |      | 10        | 0x0A | 1               | R     | uint8                   |                 | 0xD2                                | -  |
| DeviceID 2               |       |      | 11        | 0x0b | 1               | R     | uint8                   |                 | 0x01                                | -  |
| DeviceID 3               |       |      | 12        | 0x0c | 1               | R     | uint8                   |                 | 0x01                                | -  |
| <b>SYSTEM COMMAND</b>    |       |      |           |      |                 |       |                         |                 |                                     |  |
| System_command           | 2     | 0x02 |           |      | 1               | W     | uint8                   |                 | -                                   | 0x81 Application Reset<br>(Mandatory)<br>0x83 Back-To-Box<br>(Mandatory)   |
| <b>DATA STORAGE</b>      |       |      |           |      |                 |       |                         |                 |                                     |  |
| DS_Command               | 3     | 0x03 | 1         | 0x01 | 1               | R/W   | uint8                   |                 | -                                   | 0x00: Reserved<br>0x01: DS_UploadStart<br>0x02: DS_UploadEnd<br>0x03: DS_DownloadStart<br>0x04: DS_DownloadEnd<br>0x05: DS_Break<br>0x06 to 0xFF: Reserved   |
| State_Property           |       |      | 2         | 0x02 | 1               | R     | uint8                   |                 | -                                   | Bit 0: Reserved<br>Bit 1 and 2: State<br>of Data Storage<br>0b00: Inactive<br>0b01: Upload<br>0b10: Download<br>0b11: Data Storage locked<br>Bit 3 to 6: Reserved<br>Bit 7: DS_UPLOAD_FLAG<br>"1": DS_UPLOAD_REQ<br>pending<br>"0": no DS_UPLOAD_REQ |
| Data_Storage_Size        |       |      | 3         | 0x03 | 4               | R     | uint32                  |                 | 0x70                                | 0 - 0x0800   |
| Parameter_Checksum       |       |      | 4         | 0x04 | 4               | R     | uint32                  |                 | -                                   | -  |
| Index_List               |       |      | 5         | 0x05 | 11              | R     | array (of<br>octetstr3) |                 | 00 18 00 00 19 00<br>00 1A 00 00 00 | -  |
| <b>PROFILE PARAMETER</b> |       |      |           |      |                 |       |                         |                 |                                     |  |
| Profile Characteristic   | 13    | 0x0D |           |      | 2               | R     | array<br>(uint16)       |                 | 0x4000                              | -  |

## IO-LINK SERVICE DATA

| PARAMETER NAME                                | INDEX |      | SUB INDEX |     | SIZE<br>(BYTES) | ACCES | DATA<br>TYPE             | DATA<br>STORAGE | DEFAULT VALUE  | RANGE  |
|---|-------|------|-----------|-----|-----------------|-------|--------------------------|-----------------|--|--|
|   | dec   | hex  | dec       | hex |                 |       |                          |                 |  |  |
| <b>PD DESCRIPTOR</b>                          |       |      |           |     |                 |       |                          |                 |  |  |
| PD Input Descriptor                           | 14    | 0x0E |           |     | 51              | R     | 1 x array<br>(octetstr3) |                 | 01 08 00 02 08 08<br>01 10 10 01 10 20<br>01 10 30 01 10 40<br>01 10 50 01 10 60<br>01 10 70 01 10 80<br>01 10 90 01 10 A0<br>01 10 B0 01 10 C0<br>01 10 D0 01 10 E0<br>01 10 F0 | -  |
| PD Output Descriptor                          | 15    | 0x0F |           |     | 15              | R     | 1 x array<br>(octetstr3) |                 | 01 01 00 02 07 01<br>02 08 08 02 10 10<br>02 40 40   | -  |
| <b>FUNCTION CLASS IDENTIFICATION (0X8000)</b> |       |      |           |     |                 |       |                          |                 |  |  |
| Vendor Name                                   | 16    | 0x10 |           |     | 16              | R     | char[16]                 |                 | Contrinex AG   | -  |
| Vendor Text                                   | 17    | 0x11 |           |     | 32              | R     | char[32]                 |                 | www.contrinex.com  | -  |
| Product Name                                  | 18    | 0x12 |           |     | 32              | R     | char[32]                 |                 | CAM-3TIQC-C99S-xx-A  | -  |
| Product ID                                    | 19    | 0x13 |           |     | 16              | R     | char[16]                 |                 | xxx-xxx-xxx  | -  |
| Product Text                                  | 20    | 0x14 |           |     | 32              | R     | char[32]                 |                 | ToF Camera   | -  |
| Serial Number                                 | 21    | 0x15 |           |     | 16              | R     | char[16]                 |                 | 123456   | -  |
| Hardware Revision                             | 22    | 0x16 |           |     | 16              | R     | char[16]                 |                 |  | -  |
| Firmware Revision                             | 23    | 0x17 |           |     | 16              | R     | char[16]                 |                 |  | -  |
| Application Specific Tag                      | 24    | 0x18 |           |     | 32              | R/W   | char[32]                 | YES             | ***  | <user string, 32 bytes<br>(variable length)> |
| <b>FUNCTION &amp; LOCATION TAG</b>            |       |      |           |     |                 |       |                          |                 |  |  |
| Function Tag                                  | 25    | 0x19 |           |     | 32              | R/W   | char[32]                 | YES             | ***  | <user string, 32 bytes<br>(variable length)> |
| Location Tag                                  | 26    | 0x1A |           |     | 32              | R/W   | char[32]                 | YES             | ***  | <user string, 32 bytes<br>(variable length)> |
| <b>FUNCTION CLASS DIAGNOSIS (0X8003)</b>      |       |      |           |     |                 |       |                          |                 |  |  |
| Device Status                                 | 36    | 0x24 |           |     | 1               | R     | uint8                    |                 | 0= device is OK,<br>1= Maintenance<br>required, 2= out of<br>specification, 3=<br>Functional check,<br>4= Failure, 5...255<br>reserved   | 0 - 4  |
| Detailed Device Status                        | 37    | 0x25 |           |     | 9               | R     | array (of<br>octetstr3)  |                 | 00 00 00 00 00 00<br>00 00 00  |  |

## IO-LINK SERVICE DATA

| PARAMETER NAME                    | INDEX |      | SUB INDEX |      | SIZE<br>(BYTES) | ACCES | DATA<br>TYPE | DATA<br>STORAGE | DEFAULT VALUE | RANGE   |
|-----------------------------------|-------|------|-----------|------|-----------------|-------|--------------|-----------------|---------------|---|
|                                   | dec   | hex  | dec       | hex  |                 |       |              |                 |               |   |
| <b>RUNNING USE CASE PARAMETER</b> |       |      |           |      |                 |       |              |                 |               |   |
| Acquisition mode                  | 64    | 0x40 | 1         | 0x01 | 1               | R     | uint8        |                 | 0             | 0 = Continuous Mode<br>1 = Trigger mode<br>255 = Usecase not present  |
| Running Use case name             |       |      | 2         | 0x02 | 1               | R     | uint8        |                 | 0             | 0 = Multi Distance Measurement<br>1 = Defect Detection<br>2 = Level measurement<br>3 = Completeness check<br>4 = Object sizing<br>5 = Position control<br>255 = Usecase not present |
| Number of loaded Use cases        |       |      | 3         | 0x03 | 1               | R     | uint8        |                 | 0             | 0 to 64   |
| <b>CAMERA PARAMETERS</b>          |       |      |           |      |                 |       |              |                 |               |   |
| Camera HW state                   | 65    | 0x41 | 1         | 0x01 | 1               | R     | uint8        |                 | 0             | 0 = Running<br>1 = Error  |
| Image Exposure time               |       |      | 2         | 0x02 | 2               | R     | uint16       |                 | 8000          | 0 to 65535 us   |
| HDR Mode                          |       |      | 3         | 0x03 | 1               | R     | uint8        |                 | 0             | 0 = Deactivated<br>1 = Enabled  |
| HDR exposure time                 |       |      | 4         | 0x04 | 2               | R     | uint16       |                 | 0             | 0 to 65535 us   |
| Range                             |       |      | 5         | 0x05 | 1               | R     | uint8        |                 | 0             | 0 = Short range mode<br>1 = Long range mode   |
| <b>CAMERA MONITORING UNIT</b>     |       |      |           |      |                 |       |              |                 |               |   |
| Interface board temp              | 66    | 0x42 | 1         | 0x01 | 2               | R     | int16        |                 | N/A           | 0 to 150  |
| Min interface board temp          |       |      | 2         | 0x02 | 2               | R     | int16        |                 | N/A           | 0 to 150  |
| Max Interface board temp          |       |      | 3         | 0x03 | 2               | R     | int16        |                 | N/A           | 0 to 150  |
| IR board temp                     |       |      | 4         | 0x04 | 2               | R     | int16        |                 | N/A           | 0 to 150  |
| Min IR board temp                 |       |      | 5         | 0x05 | 2               | R     | int16        |                 | N/A           | 0 to 150  |
| Max IR board temp                 |       |      | 6         | 0x06 | 2               | R     | int16        |                 | N/A           | 0 to 150  |
| CPU temperature                   |       |      | 7         | 0x07 | 2               | R     | int16        |                 | N/A           | 0 to 150  |
| Min CPU temperature               |       |      | 8         | 0x08 | 2               | R     | int16        |                 | N/A           | 0 to 150  |
| Max CPU temperature               |       |      | 9         | 0x09 | 2               | R     | int16        |                 | N/A           | 0 to 150  |
| Lifetime Operating Hours          |       |      | 10        | 0x10 | 4               | R     | int16        |                 | N/A           | 0 to 150  |
| Lifetime poweron cycle            |       |      | 11        | 0x11 | 4               | R     | int16        |                 | N/A           | 0 to 150  |
| <b>OSS</b>                        |       |      |           |      |                 |       |              |                 |               |   |
| Pin Polarity                      | 67    | 0x43 | 1         | 0x01 | 1               | R     | uint8        |                 | 0             | 0 = PNP<br>1 = NPN  |
| OSS1 Output pin Direction         |       |      | 2         | 0x02 | 1               | R     | uint8        |                 | 0             | 0= SIO Output/ IO-link  |
| OSS2 Output pin Direction         |       |      | 3         | 0x03 | 1               | R     | uint8        |                 | 0             | 0 =SIO Output   |
| OSS3 Output Pin Direction         |       |      | 4         | 0x04 | 1               | R     | uint8        |                 | 0             | 1 = Input Trigger   |
| OSS1 Logic                        |       |      | 5         | 0x05 | 1               | R     | uint8        |                 | 0             | 0= NO<br>1 = NC<br>255 = No output  |
| OSS2 Logic                        |       |      | 6         | 0x06 | 1               | R     | uint8        |                 | 0             | 0= NO<br>1 = NC<br>255 = No output  |
| OSS3 Logic                        |       |      | 7         | 0x07 | 1               | R     | uint8        |                 | 0             | 0 = Input Trigger   |

## IO-LINK SERVICE DATA

| PARAMETER NAME          | INDEX |      | SUB INDEX |      | SIZE<br>(BYTES) | ACCES | DATA<br>TYPE | DATA<br>STORAGE | DEFAULT VALUE     | RANGE                          |
|-------------------------|-------|------|-----------|------|-----------------|-------|--------------|-----------------|-------------------|--------------------------------|
|                         | dec   | hex  | dec       | hex  |                 |       |              |                 |                   |                                |
| <b>NETWORK SETTINGS</b> |       |      |           |      |                 |       |              |                 |                   |                                |
| IP address              | 68    | 0x44 | 1         | 0x01 | 16              | R     | char[16]     |                 | 192.168.0.10      | N/A                            |
| Subnet mask             |       |      | 2         | 0x02 | 16              | R     | char[16]     |                 | 255.255.255.0     | N/A                            |
| Gateway IP              |       |      | 3         | 0x03 | 16              | R     | char[16]     |                 | 0.0.0.0           | N/A                            |
| DHCP Enabled            |       |      | 4         | 0x04 | 1               | R     | uint8        |                 | 0                 | 0 = No<br>1 = Yes<br>255 = N/A |
| Mac Address             |       |      | 5         | 0x05 | 16              | R     | char[16]     |                 | xx:xx:xx:xx:xx:xx | N/A                            |

## IO-LINK ERROR

| Error Code |      | Error Type                   | Description  |
|------------|------|------------------------------|--|
| DEC        | HEX  |                              |  |
| 32785      | 8011 | Index Not Available          | The addressed Index is not implemented in the device or cannot be accessed in the current device state.  |
| 32786      | 8012 | Subindex Not Available       | The addressed Subindex does not exist for the chosen Index or cannot be accessed in the current device state.  |
| 32803      | 8023 | Access Denied                | The requested access is not permitted. Possible reasons include: write protection active, insufficient access level, or the parameter is locked by the device state. |
| 32816      | 8030 | Parameter Value Out of Range | The written parameter value is outside the permitted range defined by the device.  |
| 32819      | 8033 | Parameter Length Overrun     | The transferred data block contains more bytes than expected for the selected Index/Subindex   |
| 32820      | 8034 | Parameter Length Underrun    | The transferred data block contains fewer bytes than expected for the selected Index/Subindex.   |
| 32821      | 8035 | Function Not Available       | The requested function or command is not supported by the device, or is not available in the current operating state.  |

## IO-LINK EVENTS

| Error Code |     | Event Type | Device Status | Event Description | Corrective Action |
|------------|-----|------------|---------------|-------------------|-------------------|
| DEC        | HEX |            |               |                   |                   |
|            |     |            |               |                   |                   |
|            |     |            |               |                   |                   |
|            |     |            |               |                   |                   |
|            |     |            |               |                   |                   |
|            |     |            |               |                   |                   |