



High-performance
Light Barrier



Safety
Light Barrier



Compact
Light Barrier



Fork
Light Barrier



Special
Light Barrier

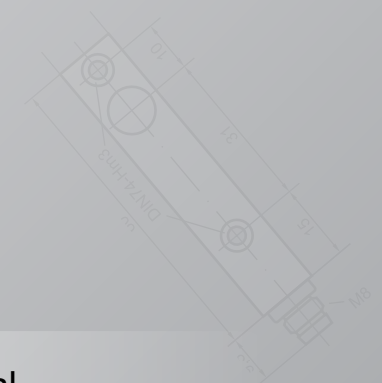
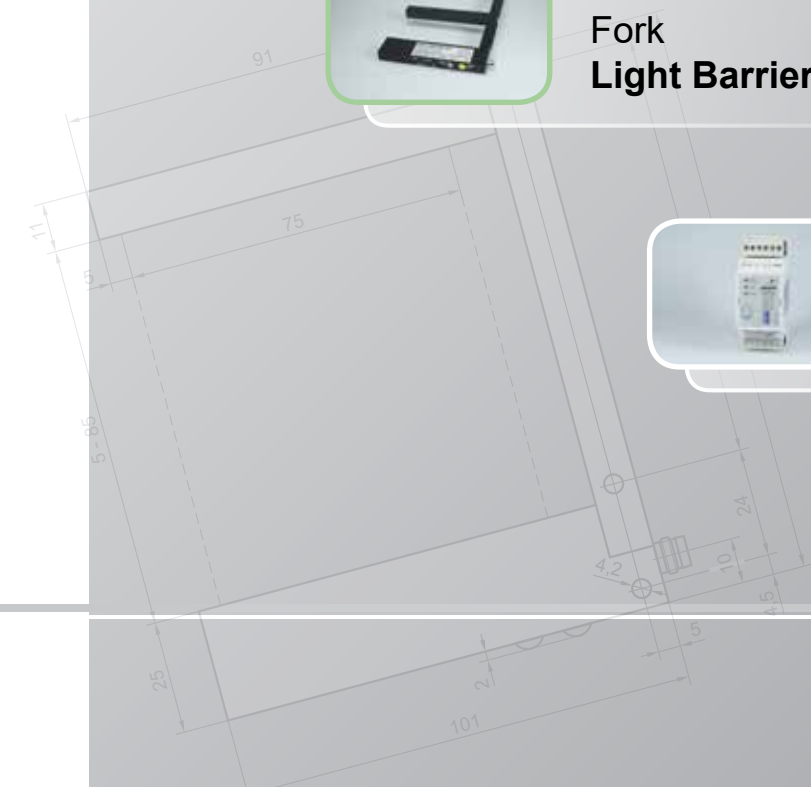
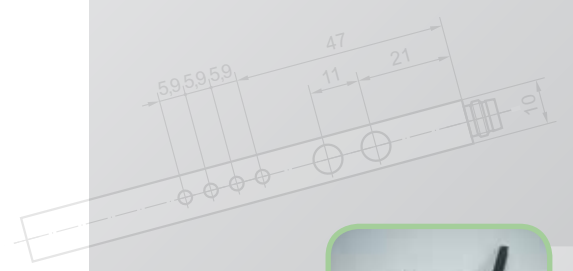
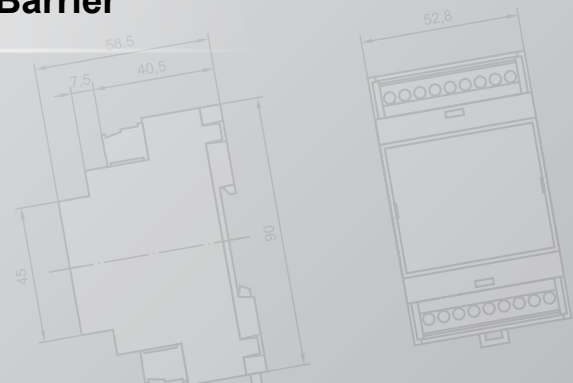



Safety instructions

The devices of the series ICL, ILD, IMX, ISG and ISM are not to be used for applications where personal safety is dependent on their function.



All Pantron products fulfil the following approval:



All technical specifications refer to the state of art 06/2018. Subject to modifications.

High-performance light barrier	General description / Applications	page 6
	Product overview	page 7
	Series ISM-... (1-channel and multichannel amplifiers)	page 8
	Series ICL-... (Multichannel amplifiers)	page 18
	Series ISG-N... (1-channel amplifiers)	page 21
	Series ISG-N1... (1-channel amplifiers)	page 24
	Series ISG-A1... (1-channel automatic amplifiers)	page 26
	Series IMX-N... (Multichannel amplifiers)	page 30
	Series IMX-A... (Multichannel automatic amplifiers)	page 36
	Special amplifiers	
	Light detector ILD-1000 (arc welding)	page 43
	1-channel amplifiers ISM-1230 (Dust and turbidity measurement)	page 44
	1-channel amplifiers ISG-A103 (Gate systems with rubber safety edge)	page 45
	Special amplifiers (Car wash applications)	
Series ISM-... (1-channel and multichannel amplifiers)	page 46	
ISG-A101 (1-channel automatic amplifiers)	page 50	
ISG-A104 (1-channel automatic amplifiers / replacement for IGW1.A)	page 51	
Series ICL-... (Multichannel amplifiers)	page 52	
Dimension drawings	page 55	
Sensors	Technical Data	page 58
	Range overview / Connection diagram	page 58
	Product overview	page 59
	Dimension drawings	page 60
Safety light barrier	Safety light barrier amplifiers ISL-8000	page 62
	Safety sensors IST-... / ISR-...	page 63
	Product overview (Safety sensors)	page 64
Compact light barrier	General description / Applications	page 66
	Safety instructions / Range overview / Dimension drawings	page 67
	Transmitter ST...	page 68
	Receiver SR...	page 70
Fork light barrier	General description Fork light barrier	page 74
	Fork light barrier FSI-... / FSR-...	page 75
	Dimension drawings	page 76
Accessories	Protective enclosure PanBox	page 78
	Power supply unit PSU-1000 / PSU-1200	page 80
	Measurement amplifiers ISG-N124M / Interfacebox IFB-1	page 82
	Communication cable CAB-COM / Connection cable CAB-M	page 84
	Measurement cable CAB-TEST / Glass fiber optic cable FOI...	page 84
	DIN-socket / Retaining clip / Accessories for sensors / Software	page 85

Automatic operation

In this operation mode the transmit power will adjust automatically depending on environmental conditions. Disturbing influences will be permanently adjusted, so that the switching sensitivity is constant over the whole power range.

Ambient light immunity

Ambient light is the light from other light sources. The light immunity is the maximum allowed illumination level from other light sources beyond that which is normally received from the receiver, which will allow the system to work safely.

Dark mode

see Switching behaviour

Diffuse light proximity

A light proximity, where light transmitter and light receiver are arranged side by side.

Infrared light

Infrared light is described as a radiation with a wavelength from 780 nm up to 1500 nm. Above this level is visible light.

Light barrier

A light barrier is an arrangement from one or more light transmitters with one or more light receivers illuminated by a light beam. The changing of the illumination will be converted to an electrical signal.

Light curtain

By the light curtain mode, the switching signal from several channels will be collected on one switching output. The additional wiring by connection of the switching outputs in serial or in parallel can be reduced.

Light mode

see Switching behaviour

Light proximity

A light proximity is an arrangement from one or more light transmitters which illuminate an object. The light, which reflects from the object will be received from one or more light receivers. The changing of the reflective light will be converted to an electrical signal.

Manual operation

The transmit power will be adjusted manually to the ambient conditions by the user.

Master/Slave operation

Several amplifiers of the same type can be synchronized by the Master/Slave connection. Disturbance from other amplifier light barriers can be prevented.

Maximum range

The maximum range is the maximum usable distance between the transmitter and receiver of a through beam light barrier. The amplifier must be set on the maximum sensitivity and on the highest basic transmit level.

Modulated light

Modulated light changes intensity with a specific frequency (see transmit frequency).

Multiplex-amplifier

Multiplex-amplifier, referred to as "amplifier", is the combination of several light barriers controlled as one with each channel activated in sequence. By this method, interference may be prevented between each light barrier.

Multiplex speed

The multiplex speed is the required time to activate all light barriers of an amplifier, one after the other.

NPN-Output

The NPN-output includes a transistor, which the load switches to the ground. The load will be connected between the operating voltage and the output.

Operating voltage

The operating voltage consists of a nominal voltage and a tolerance. The specified nominal voltage is the voltage for which the device is designed. The tolerance is the maximum deviation from the nominal voltage. This information follows the voltage range, within which, the device will reliably work. To exceed or remain under the voltage range is not advised.

PNP-Output

The PNP-output includes a transistor, which the load switches to the operating voltage. The load will be connected between the output and the ground.

Power level

Choosing between the different available power levels allows the amplifier to adjust to different applications.

Protection class

The protection class describes the protection of the device against the touching, ingress from objects or moisture according to EN 6529. The protection name starts with the character IP (International Protection) and the first number as an indicator for direct contact and ingress from objects. The second number is the protection against water. The bigger the number is, the higher the respective protection.

Push-Pull circuit

The push-pull circuit is a connection from a PNP-output and an NPN-output in series. They form a common transistor output where the connection of the load causes one of the two outputs to be activated. Do not connect sensors with a push-pull circuit in parallel.

Reaction time

The time between interruption or clearance of the light beam and the change of the output status is called reaction time.

Retro reflective light barrier

A light barrier, where the light from the transmitter is reflected by a reflector back to the receiver. Light transmitter and light receiver are arranged side by side.

Sensitivity indicator

The received signal power is displayed by the sensitivity indicator. This is illuminated constantly when the received signal is sufficient. If it flashes or goes off completely, then the signal is too low.

Switching behaviour

The switching behaviour describes the behaviour of the switching output when the beam of the light barrier is interrupted or cleared. When the amplifier is set to light mode, there is a constant output as long as the beam is present. In the dark mode, the output occurs only when the beam is interrupted.

Switching delay

Switching-on or switching-off delay controls the reaction of the switching output. The switching-on delay is the time between change of the beam status and turning the switching output on. The switching-off delay is the time between change of the beam status and turning the switching output off.

Switching frequency

The maximum switching frequency is the maximum number of signal changes at the output per second, when the duty-cycle is constant.

Test input

To check the function of the system, the light of the transmitter can be switched off by this input. After activating, the switching output must change the status.

Test function

To determine malfunctions or defects at the sensor head, a control unit is included. The amplifier will indicate whether the transmitter or the receiver is defective. If nothing is defective, the test function shows the signal quality. A green LED flashes from 1 up to 10 times. The flashes are proportional to the received signal.

Teach function

The teach function enables the user to program the switching point of the switching output. The user can decide whether the object should be recognized or should not be recognized.

Through beam light barrier

A light barrier, which will deliver light from the transmitter to the receiver. Transmitter and receiver are separately arranged.

Transmit frequency

The transmit frequency is the number of light impulses per second.

High-performance light barrier



Overview

Description	S. 6
Applications	S. 6
Product overview amplifier	S. 7

Description

High-performance Light Barrier ...

... were specially developed for areas of application in which traditional photo-electric sensors reach their limits. Pantron devices are internationally successful state-of-the-art products made in Germany.

Extreme dirt resistance and a long range make them particularly suitable for most difficult applications. The system's high power guarantees excellent penetration, even in the case of extreme contamination. Chips, dust, flour, oil or muddy water are no longer an obstacle. They are perfectly suitable for use in the timber and paper industry, in car wash systems, for controlling bulk material, in elevators, for outdoor gate control, in the food processing industry and in many other applications.

Each system consists of a transmitter, a receiver and an amplifier. Transmitters and receivers are available in different, highly compact designs so they can be installed in any applications.

Thanks to their large field of view, they can be easily aligned, even at distances of 70 meters.

Simultaneously, they are insensitive to shock, vibrations and a degree of misalignment.

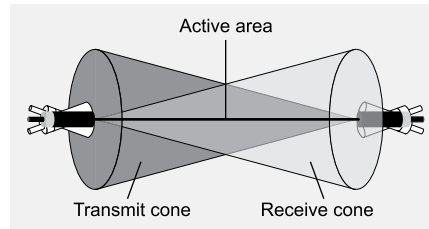

The simple installation of the amplifiers and sensors as well as the uncomplicated handling of the devices emphasize the high user friendliness.

Amplifiers are available in different variations, starting with the base unit, a manual amplifier that adjusts with a potentiometer. Also available is an automatic amplifier with automatic adjustment to disturbing influences. For applications where multiple sets of sensors are needed, a fast 8-channel multiplex amplifier is available. With this wide range of products, no application is impossible.

The sensors can be mounted according to different operating principles as required:



Through beam

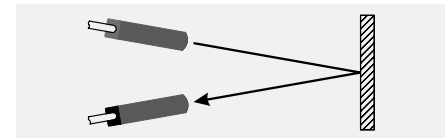

Retro reflective

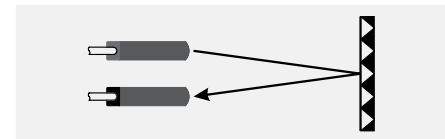

Diffuse proximity

Applications

Through beam light barrier

- Harsh and dirty to control the levels of bulk material in silos
- Gate control in industrial sectional gates, also outdoor in rain, snow and fog
- Door control in passenger and industrial elevators
- Extremely dusty environments, such as cement or gravel plants

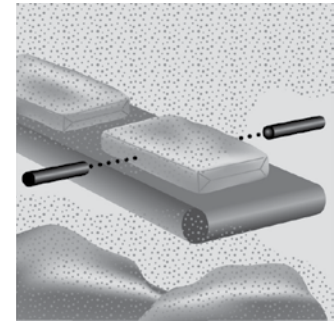
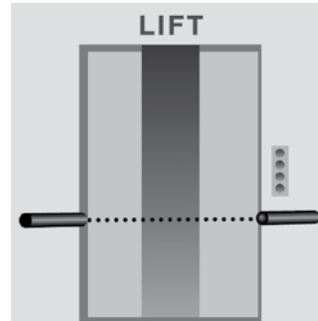
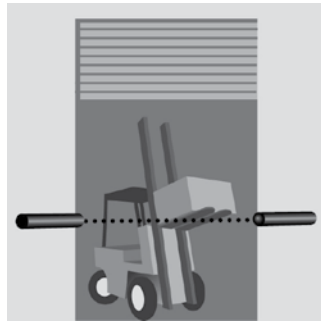
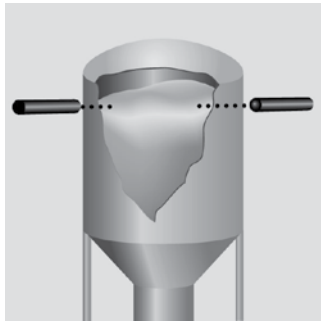

Multichannel light barrier

- High humidity, with a high condensation of water and drizzle on the optical system, as in vehicle wash systems

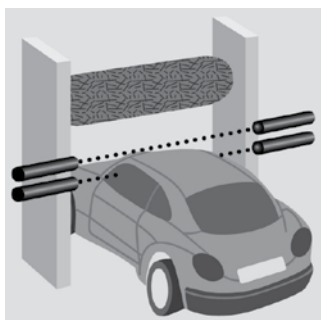

Light curtain

- Multiplex amplifiers in an extremely dirty environment, as in measuring the thickness of tree trunks in sawmills

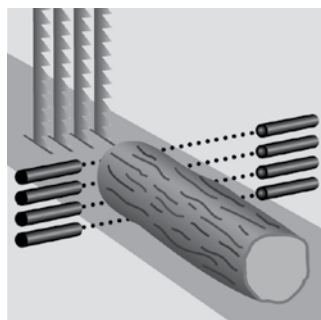

Diffuse proximity

- Detecting piece material

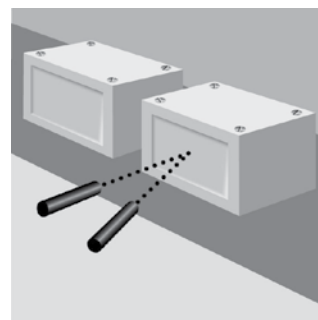

Retro reflective light barrier

- Detecting piece material

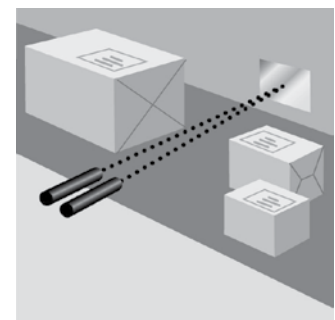

Series		light barriers (channels)	maximum range [m] (through beam)	transmit power adjustment (automatic)	transmit power adjustment (manual)	switching behaviour (light)	switching behaviour (dark)	switching delay	switching output					basic transmit level	sensor control	transmit frequency	master/slave operation	teach function	analog output	alarm output	test input	connection				page
									relay (normally open)	relay (change over)	semiconductor relay	transistor (PNP)	transistor (NPN)									DIN-plug	plug (screw terminals)	plug (spring clamp terminals)	screw terminals	
ISM	ISM-1000	1	55		•	•							1	1						•	•		8			
	ISM-1000S	1	55		•	•							1	1						•		•	8			
	ISM-1100	1	55		•	•	•						2	4						•	•		9			
	ISM-1100S	1	55		•	•	•						2	4						•	•		9			
	ISM-1200	1	55	•	•	•	•						2	•	2			•	•	•		•		10		
	ISM-1200S	1	55	•	•	•	•						2	•	2			•	•	•		•		10		
	ISM-1220S	1	50	•	•	•	•	•			•		4	•	2					•	•		•	11		
	ISM-1510	1	70		•	•	•			•			1	1								•		12		
	ISM-1515	1	70		•	•	•						1	1								•		12		
	ISM-1516	1	70		•	•	•						1	1								•		12		
	ISM-1520	1	70		•	•	•			•			1	1								•		13		
	ISM-1525	1	70		•	•	•						1	1								•		13		
	ISM-1530	1	70		•	•	•	•		•			1	1								•		14		
	ISM-1535	1	70		•	•	•	•					1	1								•		14		
	ISM-2000	2	55	•	•	•	•						4	•	1					•	•		•	15		
	ISM-2000S	2	55	•	•	•	•						4	•	1					•	•		•	15		
	ISM-4000	4	60	•	•	•	•	•					6	•	1	•			•	•	•		•	16		
ISM-8000	8	60	•	•	•	•	•					6	•	1	•			•	•	•		•	17			
ICL	ICL-2100	2	35	•	•	•	•					4	•	1	•			•	•	•		•	18			
	ICL-6100	6	35	•	•	•	•					4	•	1	•			•	•	•		•	19			
	ICL-8100	8	35	•	•	•	•					4	•	1	•			•	•	•		•	20			
ISG	ISG-N14	1	70		•	•						1	1								•		21			
	ISG-N24	1	70		•	•	•					2	4							•	•		22			
	ISG-N27	1	70		•	•	•					2	4							•	•		23			
	ISG-N34	1	70		•	•	•	•				2	4							•	•		22			
	ISG-N37	1	70		•	•	•	•				2	4								•	•	23			
	ISG-N127	1	55		•	•	•					2	•	4							•	•	24			
	ISG-N128	1	55		•	•	•					2	•	4							•	•	25			
	ISG-N137	1	55		•	•	•	•				2	•	4							•	•	24			
	ISG-N138	1	55		•	•	•	•				2	•	4							•	•	25			
	ISG-A113	1	50	•		•							2	1							•	•	26			
	ISG-A114	1	50	•		•							2	1							•	•	26			
	ISG-A123	1	50	•		•	•						4	2						•	•	•	27			
	ISG-A124	1	50	•		•	•						4	2						•	•	•	27			
	ISG-A133	1	50	•		•	•	•					4	2							•	•	•	28		
ISG-A134	1	50	•		•	•	•					4	2							•	•	•	28			
ISG-A143	1	50	•		•	•						2	2			•				•	•	•	29			
ISG-A144	1	50	•		•	•						2	2			•				•	•	•	29			
IMX	IMX-N23	2	50		•	•	•					2	1								•		30			
	IMX-N24	2	50		•	•	•			•		2	1								•		30			
	IMX-N33	2	50		•	•	•	•				2	1								•		31			
	IMX-N34	2	50		•	•	•	•				2	1								•		31			
	IMX-N430	4	40		•	•	•	•				2	1	•								•	32			
	IMX-N440	4	40		•	•	•	•			•	2	1	•								•	33			
	IMX-N830	8	40		•	•	•	•				2	1	•								•	34			
	IMX-N840	8	40		•	•	•	•				2	1	•								•	35			
	IMX-A2023	2	40	•		•	•						4	1								•		36		
	IMX-A2024	2	40	•		•	•						4	1								•		36		
	IMX-A2033	2	40	•		•	•	•					4	1								•		37		
	IMX-A2034	2	40	•		•	•	•					4	1								•		37		
	IMX-A830	8	55	•		•	•	•					2	1	•								•	38		
	IMX-A832	8	55	•		•	•	•					4	1	•								•	38		
IMX-A840	8	55	•		•	•	•					2	1	•								•	39			
IMX-A842	8	55	•		•	•	•					4	1	•								•	39			



1-channel amplifier ISM-1000

- Detection range up to 55 m
- Manual operation
- Switching behaviour light
- Floating distance switching output - short circuit proof
- Test input for system check
- Mounting for DIN rail (EN 60715)

Technical data (at 20°C)

Operating voltage	24 V DC / ±20% / 2.4 W
Operating basis	modulated infrared light
Transmit frequency	4.0 kHz
Transmit power	manual
Basic transmit level	high
Switching behaviour	light
Switching delay	—
Multiplex speed	—
Master/Slave operation	—
Switching output	semiconductor relay, normally open
Operation values (max.)	100 mA / 60 V AC (DC)
Reaction time	24 ms
Alarm output / Error output	— / —
Test input	0 ... 30 V DC
Analog output	—
COM-Interface	—
Housing material	NORYL, grey
Protection class (EN 60529)	IP 20
Connection	see purchase order table
Wire size	0.14 ... 2.5 mm ²
Operating temperature	-25 °C ... 50 °C
Dimensions (W x H x D)	35.5 x 90 x 58.5 mm
ISM-1000	see picture 3 on page 55
ISM-1000S	see picture 4 on page 55

For more detailed information see www.pantron.com

Maximum Range (through beam)

	Receiver IRL-...	Receiver IR-...
Transmitter IT-..., ITL-...	7 m	15 m
Transmitter IT-...HP, ITH-...	10 m	25 m
Transmitter ITA-...	20 m	55 m

Connection diagram

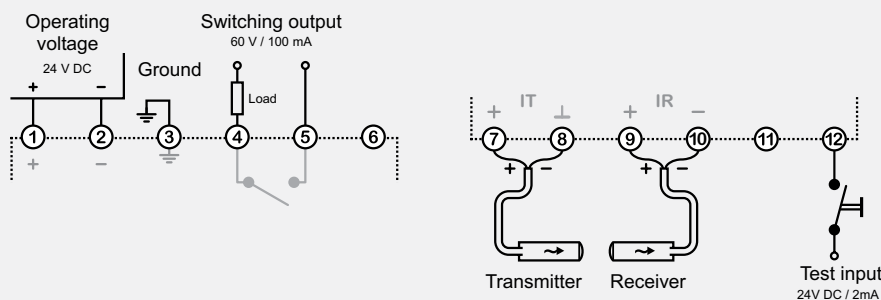

Purchase order table

Connection	Order code
Plug (screw terminals)	ISM-1000/24VDC
Screw terminals	ISM-1000S/24VDC

Accessories	Order code	Page
Protective enclosure	PanBox 1x1	78
Power supply PSU-1000	PSU-1000S/95...265VAC	80

Device description

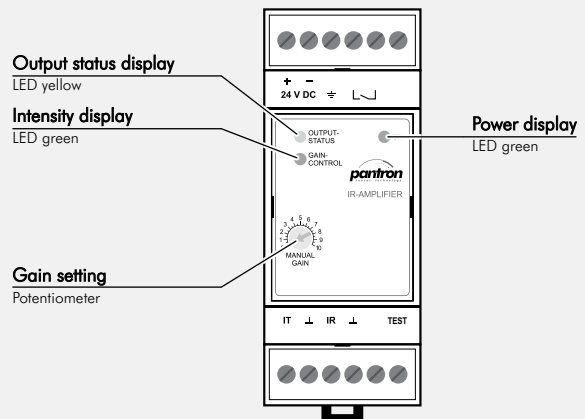

1-channel amplifier ISM-1100

- Detection range up to 55 m
- Manual operation
- Basic transmit level 2-fold selectable
- Switching behaviour light / dark selectable
- Transmit frequency 4-fold selectable
- Floating distance switching output - short circuit proof
- Alarm output for power limit
- Test input for system check
- Mounting for DIN rail (EN 60715)



Purchase order table		
Connection	Order code	
Plug (screw terminals)	ISM-1100/24VDC	
Screw terminals	ISM-1100S/24VDC	
Accessories		
Accessories	Order code	Page
Protective enclosure	PanBox 1x1	78
Power supply PSU-1000	PSU-1000S/95...265VAC	80

Device description

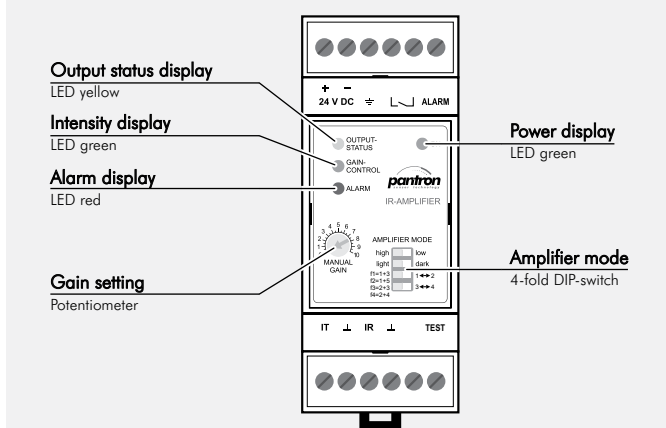

Technical data (at 20°C)	
Operating voltage	24 V DC / ±20% / 2.4 W
Operating basis	modulated infrared light
Transmit frequency	3.5 kHz / 3.8 kHz / 4.0 kHz / 4.5 kHz
Transmit power	manual
Basic transmit level	low / high
Switching behaviour	light / dark
Switching delay	—
Multiplex speed	—
Master/Slave operation	—
Switching output	semiconductor relay, normally open
Operation values (max.)	100 mA / 60 V AC (DC)
Reaction time	24 ms
Alarm output / Error output	PNP / —
Operation values (max.)	100 mA / 24 V DC
Test input	0 ... 30 V DC
Analog output	—
COM-Interface	—
Housing material	NORYL, grey
Protection class (EN 60529)	IP 20
Connection	see purchase order table
Wire size	0.14 ... 2.5 mm ²
Operating temperature	-25 °C ... 50 °C
Dimensions (W x H x D)	35.5 x 90 x 58.5 mm
ISM-1100	see picture 3 on page 55
ISM-1100S	see picture 4 on page 55

Amplifier mode (factory setting is marked white)

1	Basic transmit level	high	low		
		<input checked="" type="checkbox"/>	<input type="checkbox"/>		
2	Switching behaviour	light	dark		
		<input checked="" type="checkbox"/>	<input type="checkbox"/>		
3	Transmit frequency	3.5 kHz	3.8 kHz	4.0 kHz	4.5 kHz
		<input checked="" type="checkbox"/>	<input type="checkbox"/>	<input type="checkbox"/>	<input type="checkbox"/>
		<input type="checkbox"/>	<input checked="" type="checkbox"/>	<input type="checkbox"/>	<input type="checkbox"/>
		<input type="checkbox"/>	<input type="checkbox"/>	<input checked="" type="checkbox"/>	<input type="checkbox"/>
4					

For more detailed information see www.pantron.com

Maximum Range (through beam)

	Receiver IRL-...	Receiver IR-...
Transmitter IT-..., ITL-...	7 m	15 m
Transmitter IT-...HP, ITH-...	10 m	25 m
Transmitter ITA-...	20 m	55 m

Connection diagram

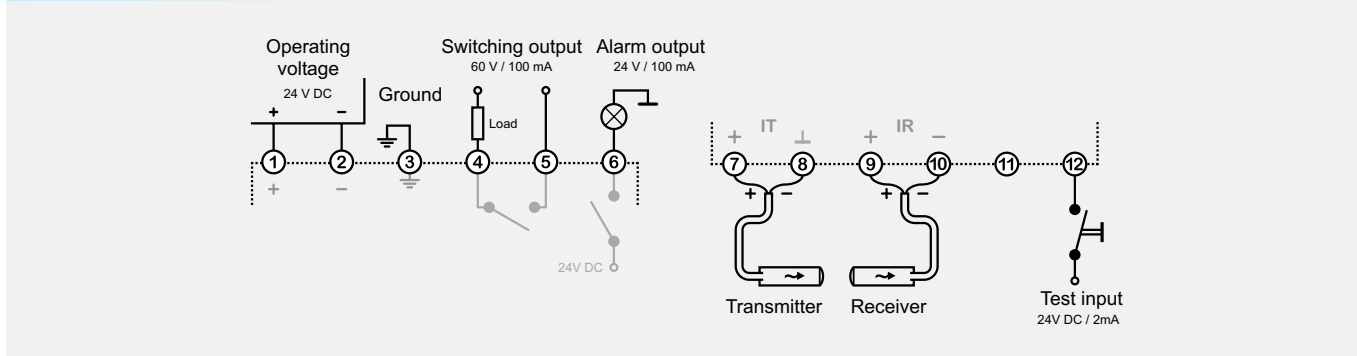



1-channel amplifier ISM-1200

- Detection range up to 55 m
- Manual / automatic operation selectable
- Basic transmit level 2-fold selectable
- Switching behaviour light / dark selectable
- Transmit frequency 2-fold selectable
- Floating distance switching output - short circuit proof
- Analog output
- Alarm output for power limit
- Test input for system check
- Sensor control
- Mounting for DIN rail (EN 60715)

Technical data (at 20°C)

Operating voltage	24 V DC / ±20% / 2.4 W
Operating basis	modulated infrared light
Transmit frequency	3.7 kHz / 4.3 kHz
Transmit power	manual / automatic
Basic transmit level	low / high
Switching behaviour	light / dark
Switching delay	—
Multiplex speed	—
Master/Slave operation	—
Switching output	semiconductor relay, normally open
Operation values (max.)	100 mA / 60 V AC (DC)
Reaction time	24 ms
Alarm output / Error output	PNP / —
Operation values (max.)	100 mA / 24 V DC
Test input	0 ... 30 V DC
Analog output	0 ... 10 V DC
COM-Interface	—
Housing material	NORYL, grey
Protection class (EN 60529)	IP 20
Connection	see purchase order table
Wire size	0.14 ... 2.5 mm ²
Operating temperature	-25 °C ... 50 °C
Dimensions (W x H x D)	35.5 x 90 x 58.5 mm
ISM-1200	see picture 3 on page 55
ISM-1200S	see picture 4 on page 55

For more detailed information see www.pantron.com

Maximum Range (through beam)

	Receiver IRL-...	Receiver IR-...
Transmitter IT-..., ITL-...	7 m	15 m
Transmitter IT-...HP, ITH-...	10 m	25 m
Transmitter ITA-...	20 m	55 m

Connection diagram

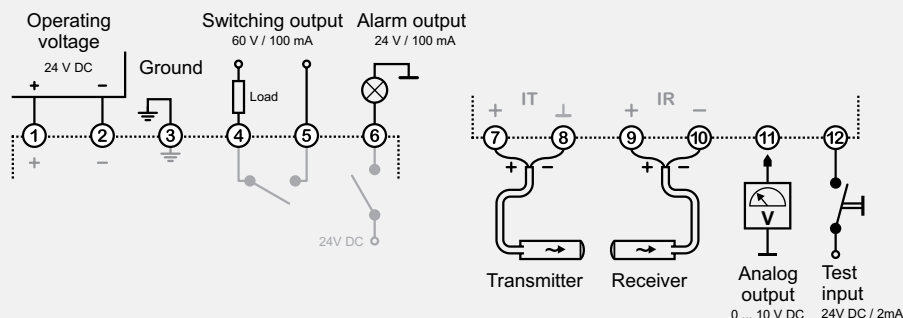

Purchase order table

Connection	Order code
Plug (screw terminals)	ISM-1200/24VDC
Screw terminals	ISM-1200S/24VDC

Accessories	Order code	Page
Protective enclosure	PanBox 1x1	78
Power supply PSU-1000	PSU-1000S/95...265VAC	80

Device description

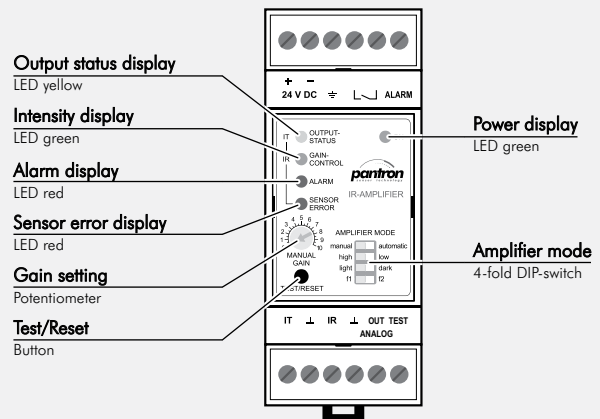

Amplifier mode (factory setting is marked white)

	1	Operation mode	manual	automatic
	2	Basic transmit level	high	low
	3	Switching behaviour	light	dark
	4	Transmit frequency	3.7 kHz	4.3 kHz

1-channel amplifier ISM-1220S

- Detection range up to 50 m
- Manual / automatic operation selectable
- Basic transmit level 2-fold selectable
- Switching behaviour light / dark selectable
- Transmit frequency 2-fold selectable
- Relay output, change over
- Alarm output for power limit
- Test input for system check
- Sensor control
- Mounting for DIN rail (EN 60715)



Purchase order table

Operating voltage	Order code
230 V AC / ± 10% / 4.8 VA	ISM-1220S/230VAC
115 V AC / ± 10% / 4.8 VA	ISM-1220S/115VAC
24 V AC / ± 10% / 4.8 VA	ISM-1220S/24VAC

Accessories	Order code	Page
Protective enclosure	PanBox 1x1	78

Device description

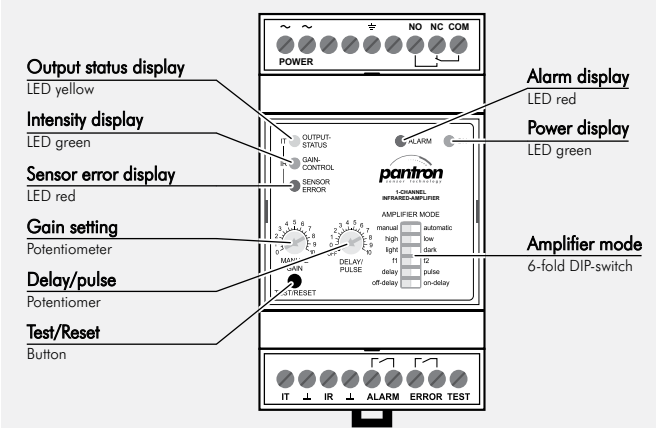

Technical data (at 20°C)

Operating voltage	see purchase order table
Operating basis	modulated infrared light
Transmit frequency	3.7 kHz / 4.3 kHz
Transmit power	manual / automatic
Basic transmit level	low / high
Switching behaviour	light / dark
Switching delay	0 ... 10 s
Multiplex speed	—
Master/Slave operation	—
Switching output	Relay, change over
Operation values (max.)	5 A / 230 V AC (24 V DC)
Reaction time	36 ms
Alarm output / Error output	2x semiconductor relay, normally open
Operation values (max.)	100 mA / 24 V DC
Test input	0 ... 30 V DC
Analog output	—
COM-Interface	—
Housing material	NORYL, grey
Protection class (EN 60529)	IP 20
Connection	screw terminals
Wire size	0.14 ... 2.5 mm ²
Operating temperature	-25 °C ... 50 °C
Dimensions (W x H x D)	52.8 x 90 x 58.5 mm see picture 6 on page 55

Amplifier mode (factory setting is marked white)

	1	Operation mode	manual	automatic
	2	Basic transmit level	high	low
	3	Switching behaviour	light	dark
	4	Transmit frequency	3.7 kHz	4.3 kHz
	5	Switching method	delay	pulse
	6	Switching reaction	on	off

For more detailed information see www.pantron.com

Maximum Range (through beam)

	Receiver IRL-...	Receiver IR-...
Transmitter IT-..., ITL-...	8 m	15 m
Transmitter IT-...HP, ITH-...	10 m	20 m
Transmitter ITA-...	20 m	50 m

Connection diagram

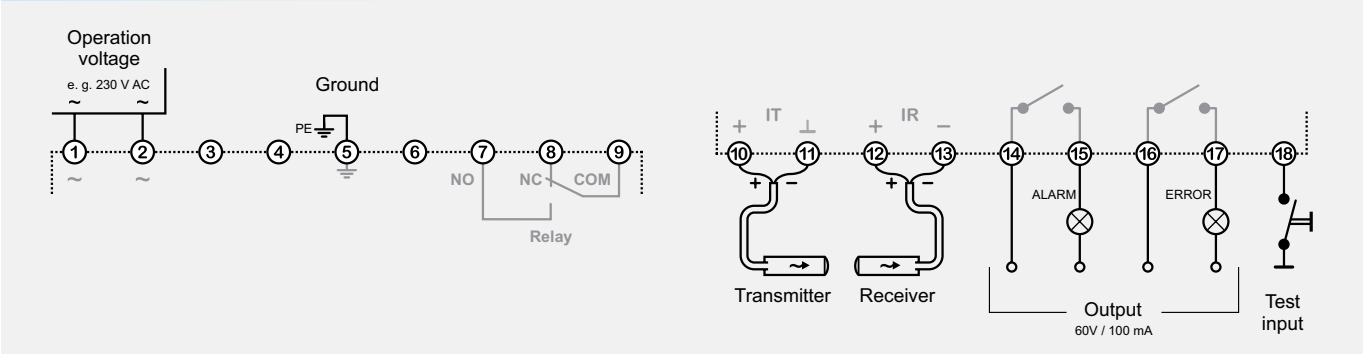



1-channel amplifier ISM-1510 / ISM-1515 / ISM-1516

- Detection range up to 70 m
- Sensitivity adjustable with potentiometer
- Operating voltage 24 V AC or DC
- Floating distance switching output (*ISM-1510* with relay and *ISM-1515 / ...16* with semiconductor relay)
- Connections are pluggable
- Mounting for DIN rail (EN 60715)

Technical data (at 20°C)

Operating voltage	24 V AC / ±10% / 2.4 VA 24 V DC / ±10% / 2.4 W
Operating basis	modulated infrared light
Transmit frequency	4.0 kHz
Transmit power	manual
Basic transmit level	high
Switching behaviour	light
Switching delay	—
Multiplex speed	—
Master/Slave operation	—
Switching output ISM-1510	relay, normally open
Operation values (max.)	5 A / 230 V AC (24 V DC)
Reaction time	36 ms
Switching output ISM-1515	semiconductor relay, normally open
Operation values (max.)	100 mA / 60 V AC (DC)
Reaction time	36 ms
Alarm output / Error output	— / —
Test input	—
Analog output	—
COM-Interface	—
Housing material	polyamide, light grey
Protection class (EN 60529)	IP 20
Connection	plug with screw terminals
Wire size	0.2 ... 2.5 mm ²
Operating temperature	-25 °C ... 50 °C
Dimensions ISM-1510 / ...15 (W x H x D)	22.5 x 94 x 84 mm see <i>picture 1</i> on page 55
Dimensions ISM-1516 (W x H x D)	22.5 x 94 x 63 mm see <i>picture 2</i> on page 55

Maximum Range (through beam)

	Receiver IRL-...	Receiver IR-...
Transmitter IT-..., ITL-...	20 m	25 m
Transmitter IT-...HP, ITH-...	30 m	35 m
Transmitter ITA-...	50 m	70 m

Connection diagram

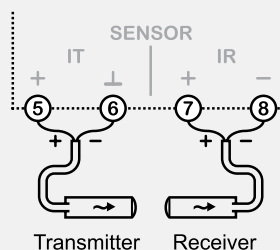
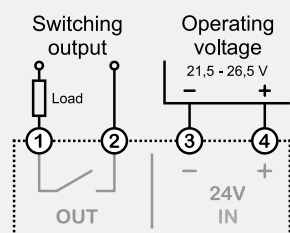

Purchase order table

Switching output	Order code	
Relay	ISM-1510/24V	
Semiconductor relay	ISM-1515/24V	
Semiconductor relay	ISM-1516/24V	
Accessories	Order code	Page
Protective enclosure	PanBox 1x1	78
Power supply PSU-1000	PSU-1000S/95...265VAC	80

Device description

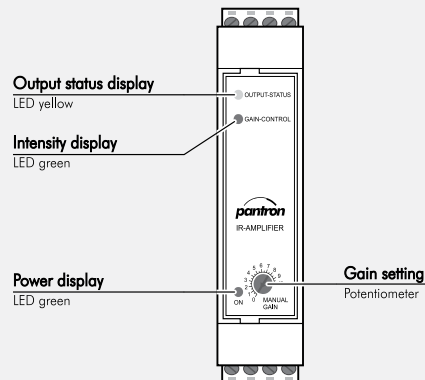

1-channel amplifier ISM-1520 / ISM-1525

- Detection range up to 70 m
- Sensitivity adjustable with potentiometer
- Operating voltage 24 V AC or DC
- Basic transmit level 2-fold selectable
- Switching behaviour light / dark selectable
- Floating distance switching output (*ISM-1520* with relay and *ISM-1525* with semiconductor relay)
- Connections are pluggable
- Mounting for DIN rail (EN 60715)



Purchase order table		
Switching output	Order code	
Relay	ISM-1520/24V	
Semiconductor relay	ISM-1525/24V	
Accessories		
Accessories	Order code	Page
Protective enclosure	PanBox 1x1	78
Power supply PSU-1000	PSU-1000S/95...265VAC	80

Device description

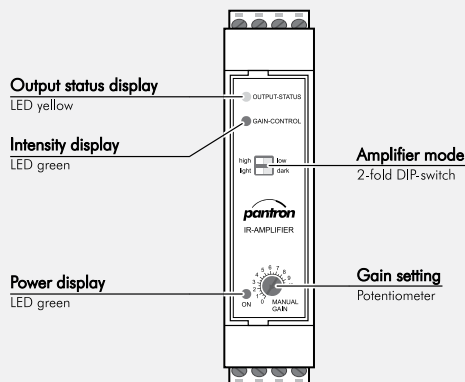

Amplifier mode (factory setting is marked white)

	1	Basic transmit level	high	low
	2	Switching behaviour	light	dark

Technical data (at 20°C)

Operating voltage	24 V AC / ±10% / 2.4 VA 24 V DC / ±10% / 2.4 W
Operating basis	modulated infrared light
Transmit frequency	4.0 kHz
Transmit power	manual
Basic transmit level	low / high
Switching behaviour	light / dark
Switching delay	—
Multiplex speed	—
Master/Slave operation	—
Switching output ISM-1520	relay, normally open
Operation values (max.)	5 A / 230 V AC (24 V DC)
Reaction time	36 ms
Switching output ISM-1525	semiconductor relay, normally open
Operation values (max.)	100 mA / 60 V AC (DC)
Reaction time	36 ms
Alarm output / Error output	— / —
Test input	—
Analog output	—
COM-Interface	—
Housing material	polyamide, light grey
Protection class (EN 60529)	IP 20
Connection	plug with screw terminals
Wire size	0.2 ... 2.5 mm ²
Operating temperature	-25 °C ... 50 °C
Dimensions (W x H x D)	22.5 x 94 x 84 mm see <i>picture 1</i> on page 55

For more detailed information see www.pantron.com

Maximum Range (through beam)

	Receiver IRL-...	Receiver IR-...
Transmitter IT-..., ITL-...	20 m	25 m
Transmitter IT-...HP, ITH-...	30 m	35 m
Transmitter ITA-...	50 m	70 m

Connection diagram

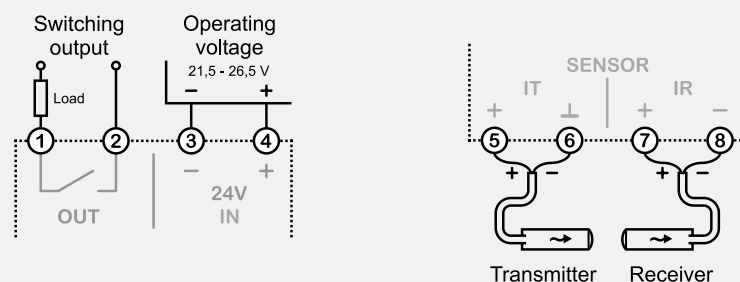



1-channel amplifier ISM-1530 / ISM-1535

- Detection range up to 70 m
- Sensitivity adjustable with potentiometer
- Operating voltage 24 V AC or DC
- Basic transmit level 2-fold switchable
- Switching behaviour light / dark selectable
- Switching-on and switching-off delay
- Floating distance switching output (**ISM-1530** with relay and **ISM-1535** with semiconductor relay)
- Connections are pluggable
- Mounting for DIN rail (EN 60715)

Technical data (at 20°C)

Operating voltage	24 V AC / ±10% / 2.4 VA 24 V DC / ±10% / 2.4 W
Operating basis	modulated infrared light
Transmit frequency	4.0 kHz
Transmit power	manual
Basic transmit level	low / high
Switching behaviour	light / dark
Switching delay	0 ... 10 s
Multiplex speed	—
Master/Slave operation	—
Switching output ISM-1530	relay, normally open
Operation values (max.)	5 A / 230 V AC (24 V DC)
Reaction time	36 ms
Switching output ISM-1535	semiconductor relay, normally open
Operation values (max.)	100 mA / 60 V AC (DC)
Reaction time	36 ms
Alarm output / Error output	— / —
Test input	—
Analog output	—
COM-Interface	—
Housing material	polyamide, light grey
Protection class (EN 60529)	IP 20
Connection	plug with screw terminals
Wire size	0.2 ... 2.5 mm ²
Operating temperature	-25 °C ... 50 °C
Dimensions (W x H x D)	22.5 x 94 x 84 mm see <i>picture 1</i> on page 55

For more detailed information see www.pantron.com

Maximum Range (through beam)

	Receiver IRL-...	Receiver IR-...
Transmitter IT-..., ITL-...	20 m	25 m
Transmitter IT-...HP, ITH-...	30 m	35 m
Transmitter ITA-...	50 m	70 m

Connection diagram

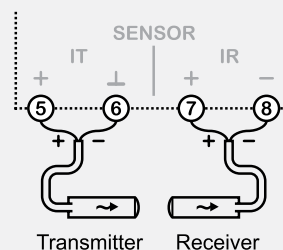
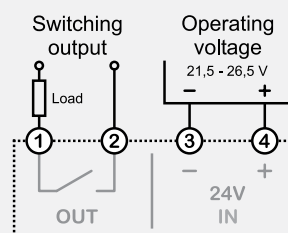

Purchase order table

Switching output	Order code
Relay	ISM-1530/24V
Semiconductor relay	ISM-1535/24V

Accessories	Order code	Page
Protective enclosure	PanBox 1x1	78
Power supply PSU-1000	PSU-1000S/95...265VAC	80

Device description

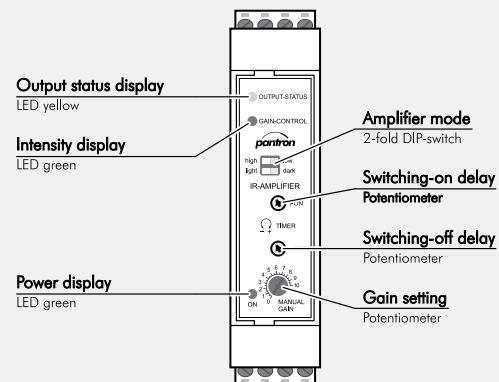

Amplifier mode (factory setting is marked white)

	1	Basic transmit level	high	low
	1			
	2	Switching behaviour	light	dark
	2			

2-channel multiplex amplifier ISM-2000

- Detection range up to 55 m
- Manual / automatic operation selectable
- Basic transmit level 2-fold selectable
- Switching behaviour light / dark selectable
- Floating distance switching outputs - short circuit proof
- Alarm output for power limit
- Test input for system check
- Sensor control
- Mounting for DIN rail (EN 60715)



Purchase order table

Connection	Order code
Plug (screw terminals)	ISM-2000/24VDC
Screw terminals	ISM-2000S/24VDC

Accessories	Order code	Page
Protective enclosure	PanBox 1x2	78
Power supply PSU-1000	PSU-1000S/95...265VAC	80

Device description

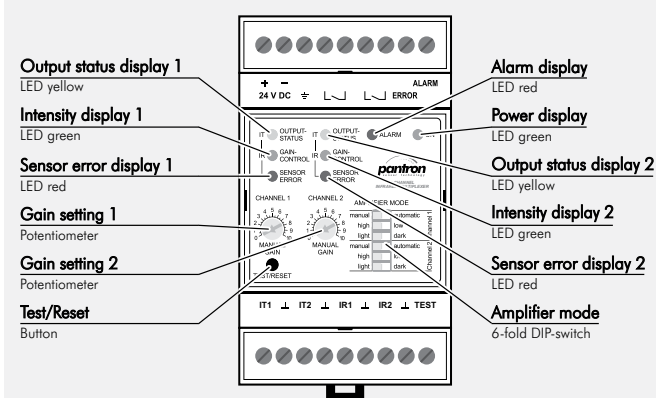

Technical data (at 20°C)

Operating voltage	24 V DC / ±20% / 3.6 W
Operating basis	modulated infrared light
Transmit frequency	3.9 kHz
Transmit power	manual / automatic
Basic transmit level	low / high
Switching behaviour	light / dark
Switching delay	—
Multiplex speed	8 ms
Master/Slave operation	—
Switching output	2x semiconductor relay, normally open
Operation values (max.)	100 mA / 60 V AC (DC)
Reaction time	24 ms
Alarm output / Error output	PNP / PNP
Operation values (max.)	100 mA / 24 V DC
Test input	0 ... 30 V DC
Analog output	—
COM-Interface	—
Housing material	NORYL, grey
Protection class (EN 60529)	IP 20
Connection	see purchase order table
Wire size	0.14 ... 2.5 mm ²
Operating temperature	-25 °C ... 50 °C
Dimensions (W x H x D)	35.5 x 90 x 58.5 mm
ISM-2000	see picture 5 on page 55
ISM-2000S	see picture 6 on page 55

Amplifier mode (factory setting is marked white)

	1	2	3	4	5	6
Operating basis channel 1	manual	automatic				
Basic transmit power channel 1	high	low				
Switching behaviour channel 1	light	dark				
Operating basis channel 2	manual	automatic				
Basic transmit power channel 2	high	low				
Switching behaviour channel 2	light	dark				

For more detailed information see www.pantron.com

Maximum Range (through beam)

	Receiver IRL-...	Receiver IR-...
Transmitter IT-..., ITL-...	10 m	15 m
Transmitter IT-...HP, ITH-...	12 m	25 m
Transmitter ITA-...	25 m	60 m

Connection diagram

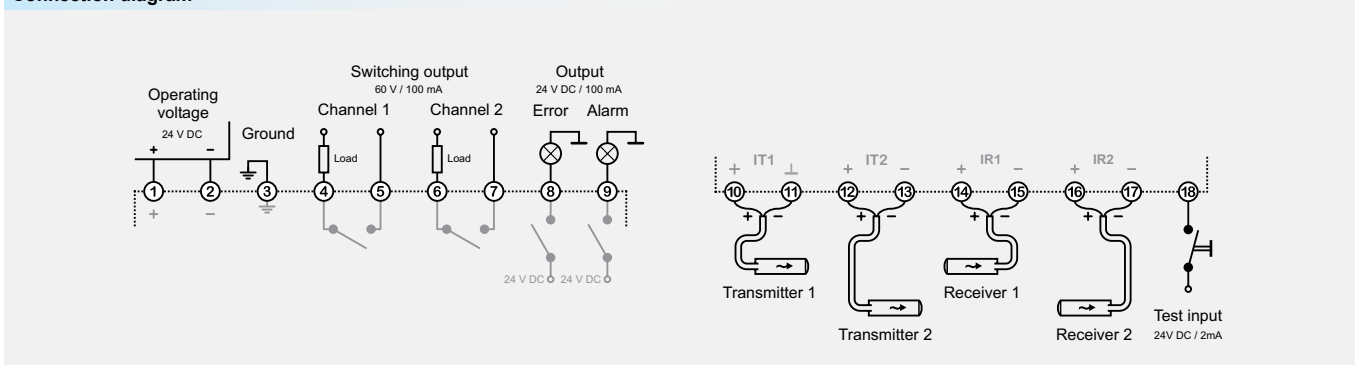



4-channel multiplex amplifier ISM-4000

- Detection range up to 60 m
- Menu-driven operation with display or PC software
- Manual / automatic operation selectable
- Switching behaviour light / dark selectable
- Switching delay
- Floating distance switching outputs - short circuit proof
- Alarm output for power limit
- Analog output
- Test input for system check
- Sensor control with error output
- Master/Slave operation
- Mounting for DIN rail (EN 60715)

Technical data (at 20 °C)

Operating voltage	24 V DC / ±20% / 6.5 W
Operating basis	modulated infrared light
Transmit frequency	4.0 kHz
Transmit power	manual / automatic
Basic transmit level - manual	man1 / man2
Basic transmit level - automatic	auto1 / auto2 / auto3 / auto4
Switching mode	light / dark
Switching delay	0 ... 60 s
Multiplex speed	18 ms
Master/Slave operation	yes
Switching output	4x Semiconductor relay, normally open
Operation values (max.)	100 mA / 60 V AC (DC)
Reaction time	20 ms
Alarm output / Error output	PNP / PNP
Operation values (max.)	100 mA / 24 V DC
Test input	max. 30 V DC / 2 mA
Analog output	0 ... 10 V DC or 10 ... 0 V DC
COM-Interface	RS232
Housing material	NORYL, grey
Protection class (EN 60529)	IP 20
Connection	plug with screw terminals
Wire size	0.14 ... 2.5 mm ²
Operating temperature	0 °C ... 50 °C
Dimensions (W x H x D)	106 x 90 x 58.5 mm see picture 7 on page 55

For more detailed information see www.pantron.com

Maximum Range (through beam)

	Receiver IRL-...	Receiver IR-...
Transmitter IT-..., ITL-...	10 m	15 m
Transmitter IT-...HP, ITH-...	12 m	25 m
Transmitter ITA-...	25 m	60 m

Connection diagram

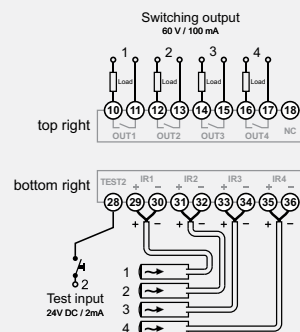
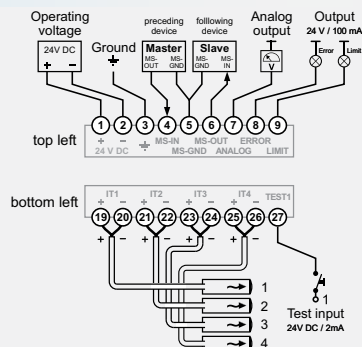

Purchase order table

Connection	Order code
Plug (screw terminals)	ISM-4000/24VDC

Accessories	Order code	Page
Protective enclosure	PanBox 1x4	79
Power supply PSU-1000	PSU-1000S/95...265VAC	80
Communication cable	CAB-COM-2	84
PC software	WinISM	85

Device description

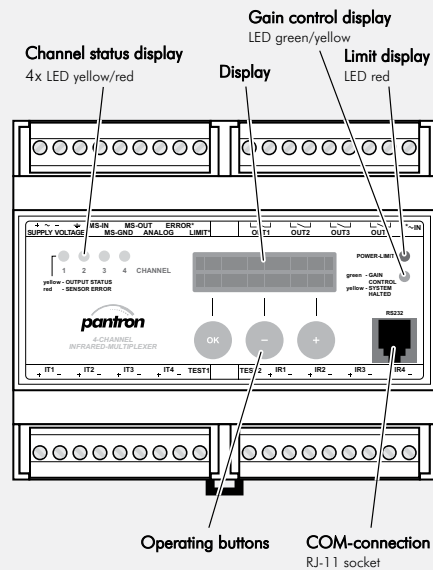

8-channel multiplex amplifier ISM-8000

- Detection range up to 60 m
- Menu-driven operation with display or PC software
- Manual / automatic operation selectable
- Switching behaviour light /dark selectable
- Switching delay
- Floating distance switching outputs - short circuit proof
- Alarm output for power limit
- Analog output
- Test input for system check
- Sensor control with error output
- Master/Slave operation
- Mounting for DIN rail (EN 60715)



Purchase order table

Connection	Order code	
Plug (screw terminals)	ISM-8000/24VDC	
Accessories	Order code	Page
Protective enclosure	PanBox 1x8	79
Power supply PSU-1000	PSU-1000S/95...265VAC	80
Communication cable	CAB-COM-2	84
PC software	WinISM	85

Device description

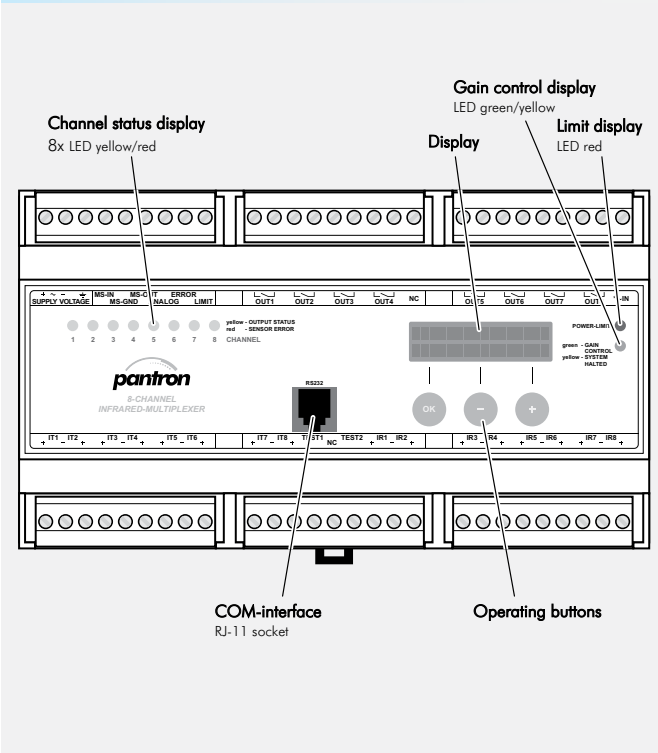

Technical data (at 20 °C)

Operating voltage	24 V DC / ±20% / 8.5 W
Operating basis	modulated infrared light
Transmit frequency	4.0 kHz
Transmit power	manual / automatic
Basic transmit level - manual	man1 / man2
Basic transmit level - automatic	auto1 / auto2 / auto3 / auto4
Switching mode	light / dark
Switching delay	0 ... 60 s
Multiplex speed	34 ms
Master/Slave operation	yes
Switching output	8x Semiconductor relay, normally open
Operation values (max.)	100 mA / 60 V AC (DC)
Reaction time	36 ms
Alarm output / Error output	PNP / PNP
Operation values (max.)	100 mA / 24 V DC
Test input	max. 30 V DC / 2 mA
Analog output	0 ... 10 V DC or 10 ... 0 V DC
COM-Interface	RS232
Housing material	NORYL, grey
Protection class (EN 60529)	IP 20
Connection	plug with screw terminals
Wire size	0.14 ... 2.5 mm ²
Operating temperature	0 °C ... 50 °C
Dimensions (W x H x D)	158.5 x 90 x 58.5 mm see picture 8 on page 55

For more detailed information see www.pantron.com

Maximum Range (through beam)

	Receiver IRL-...	Receiver IR-...
Transmitter IT-..., ITL-...	10 m	15 m
Transmitter IT-...HP, ITH-...	12 m	25 m
Transmitter ITA-...	25 m	60 m

Connection diagram

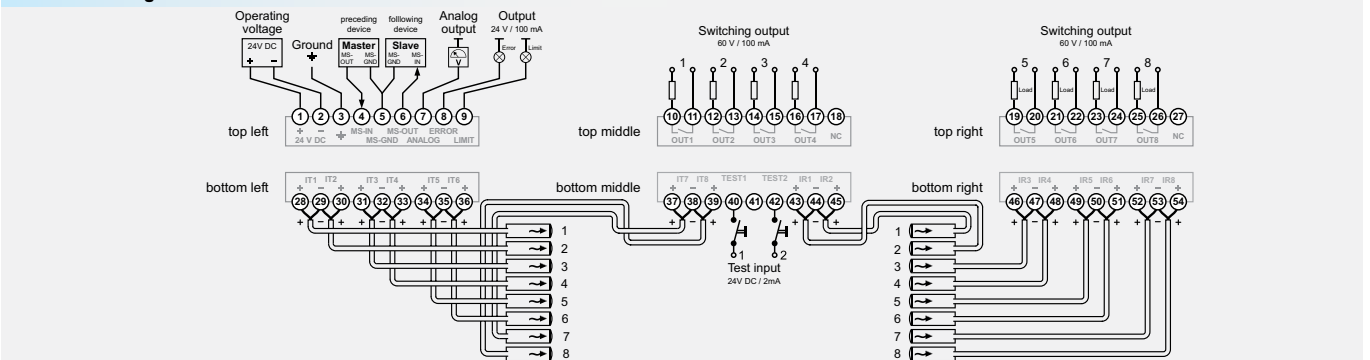



2-channel multiplex amplifier ICL-2100

- Detection range up to 35 m
- Manual / automatic operation selectable
- Switching behaviour light / dark selectable
- Switching outputs, PNP - short circuit proof
- Alarm output for power limit
- Analog output 0 - 10 V DC
- Test button with diagnostic function
- Test input for system check
- Sensor control
- COM Interface (RS232) - configuration with personal computer
- Master/Slave operation
- Mounting for DIN rail (EN 60715)

Technical data (at 20 °C)

Operating voltage	24 V DC / ±20% / 3.6 W
Operating basis	modulated infrared light
Transmit frequency	4.0 kHz
Transmit power	manual / automatic
Basic transmit level	low1 / low2 / high1 / high2
Switching behaviour	light / dark
Switching delay	—
Multiplex speed	10 ms
Master/Slave operation	yes
Switching output	2x PNP, short circuit proof
Operation values (max.)	100 mA / 24 V DC
Reaction time	12 ms
Alarm output	PNP, short circuit proof
Operation values (max.)	100 mA / 24 V DC
Test input	max. 30 V DC / 2 mA
Operate voltage	Low < 5 V DC; High > 15 V DC
Analog output	0 ... 10 V DC
COM-Interface	RS232
Housing material	Polyamide
Protection class (EN 60529)	IP 00
Connection	Phoenix Contact Typ MCV 1,5/8-G-3,81
Operating temperature	-25 °C ... 50 °C
Dimensions (W x H x D)	73 x 111 x 55 mm see <i>picture 16</i> on page 56

For more detailed information see www.pantron.com

Maximum Range (through beam)

	Receiver IRL-...	Receiver IR-...
Transmitter IT-..., ITL-...	4 m	12 m
Transmitter IT-...HP, ITH-...	7 m	19 m
Transmitter ITA-...	12 m	35 m

Connection diagram

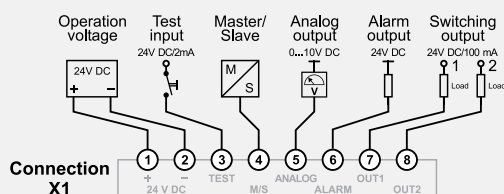

Connection X2

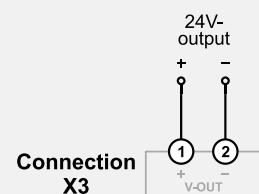
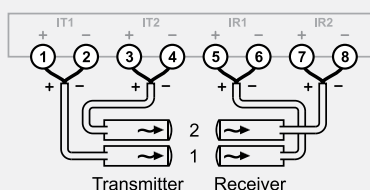

Purchase order table

Connection	Order code
Plug (spring clamp terminals)	ICL-2100/24VDC

Accessories	Order code	Page
Protective enclosure	PanBox 1x2	78
Power supply PSU-1000	PSU-1000S/95...265VAC	80
Communication cable	CAB-COM-2	84
PC software	WinICL	85

Device description

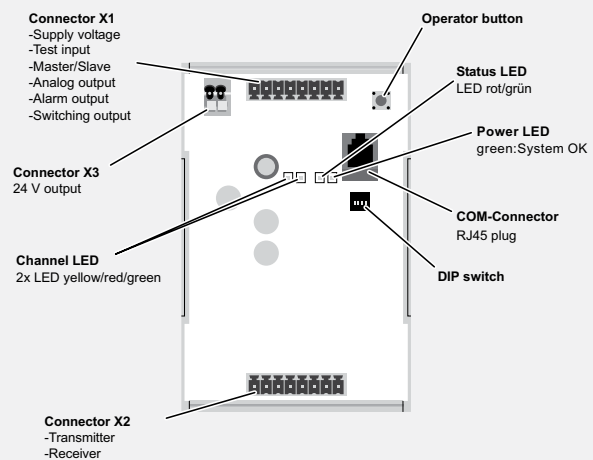

6-channel multiplex amplifier ICL-6100

- Detection range up to 35 m
- Manual / automatic operation selectable
- Switching behaviour light / dark selectable
- Switching outputs, PNP - short circuit proof
- Alarm output for power limit
- Analog output 0 - 10 V DC
- Test button with diagnostic function
- Test input for system check
- Sensor control
- COM Interface (RS232) - configuration with personal computer
- Master/Slave operation
- Mounting for DIN rail (EN 60715)

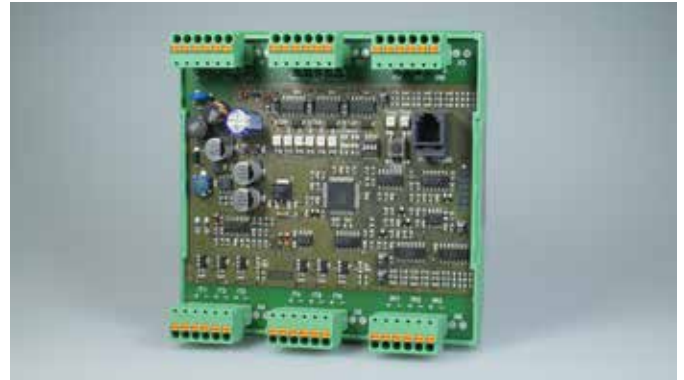

Purchase order table

Connection	Order code
Plug (spring clamp terminals)	ICL-6100/24VDC

Accessories	Order code	Page
Protective enclosure	PanBox 1x8	79
Power supply PSU-1000	PSU-1000S/95...265VAC	80
Communication cable	CAB-COM-2	84
PC software	WinICL	85

Device description

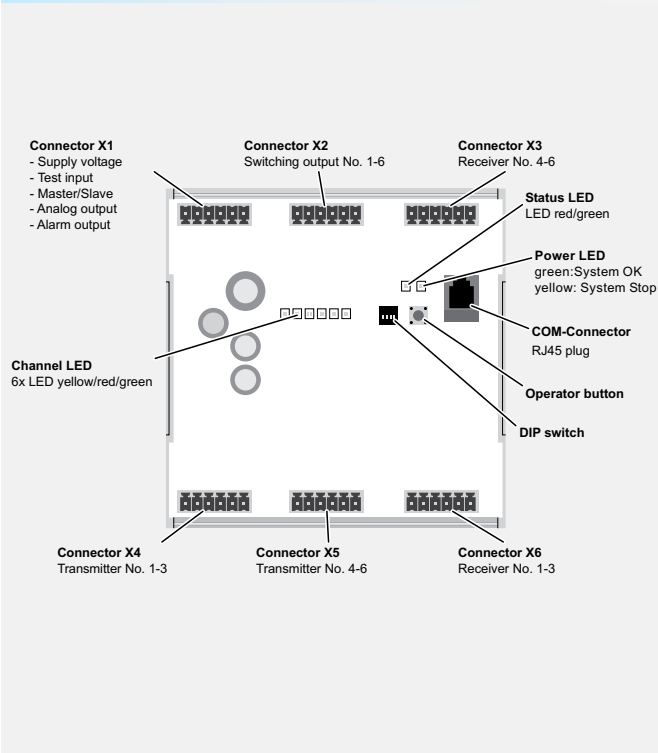

Technical data (at 20 °C)

Operating voltage	24 V DC / ±20% / 4.2 W
Operating basis	modulated infrared light
Transmit frequency	4.0 kHz
Transmit power	manual / automatic
Basic transmit level	low1 / low2 / high1 / high2
Switching behaviour	light / dark
Switching delay	—
Multiplex speed	34 ms
Master/Slave operation	yes
Switching output	6x PNP, short circuit proof
Operation values (max.)	100 mA / 24 V DC
Reaction time	36 ms
Alarm output	PNP, short circuit proof
Operation values (max.)	100 mA / 24 V DC
Test input	max. 30 V DC / 2 mA
Operate voltage	Low < 5 V DC; High > 15 V DC
Analog output	0 ... 10 V DC
COM-Interface	RS232
Housing material	Polyamide
Protection class (EN 60529)	IP 00
Connection	Phoenix Contact Typ MCV 1,5/6-G-3,81
Operating temperature	-25 °C ... 50 °C
Dimensions (W x H x D)	111 x 111 x 55 mm see picture 17 on page 56

For more detailed information see www.pantron.com

Maximum Range (through beam)

	Receiver IRL-...	Receiver IR-...
Transmitter IT-..., ITL-...	5 m	15 m
Transmitter IT-...HP, ITH-...	8 m	20 m
Transmitter ITA-...	14 m	35 m

Connection diagram

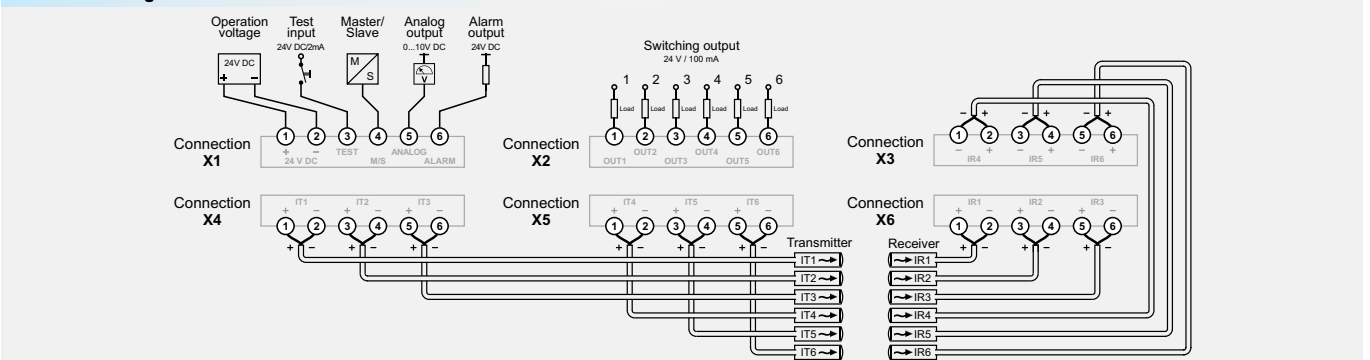

8-channel multiplex amplifier ICL-8100

- Detection range up to 35 m
- Manual / automatic operation selectable
- Switching behaviour light / dark selectable
- Switching outputs, PNP - short circuit proof
- Alarm output for power limit
- Analog output 0 - 10 V DC
- Test button with diagnostic function
- Test input for system check
- Sensor control
- COM Interface (RS232) - configuration with personal computer
- Master/Slave operation
- Mounting for DIN rail (EN 60715)

Technical data (at 20 °C)

Operating voltage	24 V DC / ±20% / 3.6 W
Operating basis	modulated infrared light
Transmit frequency	4.0 kHz
Transmit power	manual / automatic
Basic transmit level	low1 / low2 / high1 / high2
Switching behaviour	light / dark
Switching delay	—
Multiplex speed	34 ms
Master/Slave operation	yes
Switching output	8x PNP, short circuit proof
Operation values (max.)	100 mA / 24 V DC
Reaction time	36 ms
Alarm output	PNP, short circuit proof
Operation values (max.)	100 mA / 24 V DC
Test input	max. 30 V DC / 2 mA
Operate voltage	Low < 5 V DC; High > 15 V DC
Analog output	0 ... 10 V DC
COM-Interface	RS232
Housing material	Polyamide
Protection class (EN 60529)	IP 00
Connection	Phoenix Contact Typ MCV 1,5/8-G-3,81
Operating temperature	-25 °C ... 50 °C
Dimensions (W x H x D)	111 x 111 x 55 mm see picture 17 on page 56

For more detailed information see www.pantron.com

Maximum Range (through beam)

	Receiver IRL-...	Receiver IR-...
Transmitter IT-..., ITL-...	4 m	12 m
Transmitter IT-...HP, ITH-...	7 m	19 m
Transmitter ITA-...	12 m	35 m

Connection diagram

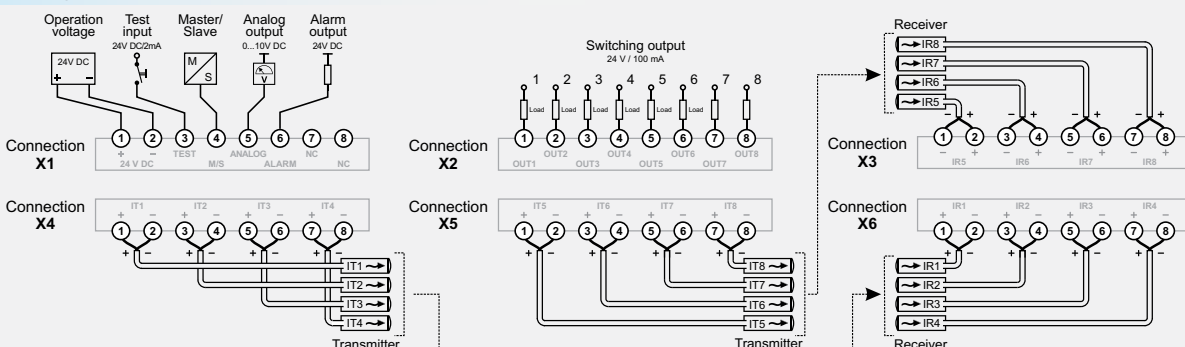

Purchase order table

Connection	Order code
Plug (spring clamp terminals)	ICL-8100/24VDC

Accessories	Order code	Page
Protective enclosure	PanBox 1x8	78
Power supply PSU-1000	PSU-1000S/95...265VAC	80
Communication cable	CAB-COM-2	84
PC software	WinICL	85

Device description

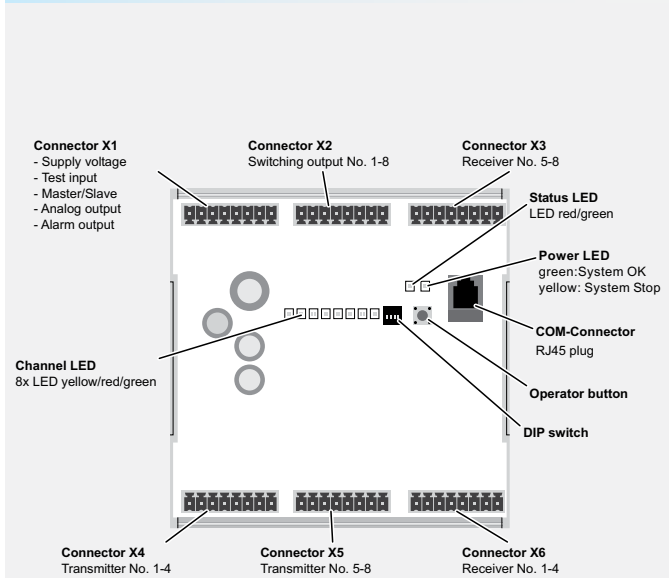

1-channel amplifier ISG-N14

- Detection range up to 70 m
- Sensitivity adjustable with potentiometer
- Relay output, change over



Purchase order table

Operation voltage	Order code	
230 V AC / ± 10% / 3.8 VA	ISG-N14/230VAC	
115 V AC / ± 10% / 3.8 VA	ISG-N14/115VAC	
24 V AC / ± 10% / 3.8 VA	ISG-N14/24VAC	
24 V DC / ± 20% / 2.0 W	ISG-N14/24VDC	
Accessories	Order code	Page
Protective enclosure	PanBox 1x1	78
11-pole DIN-socket	ISO1	85
Retaining clip	RTC 11	85

Device description

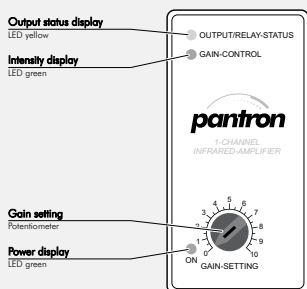

Technical data (at 20°C)

Operating voltage	see purchase order table
Operating basis	modulated infrared light
Transmit frequency	3.5 kHz
Transmit power	manual
Basic transmit level	high
Switching behaviour	light
Switching delay	—
Multiplex speed	—
Master/Slave operation	—
Switching output relay	change over
Operation values (max.)	5 A / 230 V AC (24 V DC)
Reaction time	36 ms
Switching output transistor	—
Alarm output	—
Test input	—
Analog output	—
COM-Interface	—
Housing material	plastic
Protection class (EN 60529)	IP 40
Connection	11-pole DIN-plug
Operating temperature	-25 °C ... 50 °C
Dimensions (W x H x D)	40 x 76.5 x 80 mm see picture 9 on page 55

For more detailed information see www.pantron.com

Maximum Range (through beam)

	Receiver IRL-...	Receiver IR-...
Transmitter IT-..., ITL-...	20 m	25 m
Transmitter IT-...HP, ITH-...	30 m	35 m
Transmitter ITA-...	50 m	70 m

Connection diagram

Operating voltage

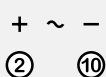

Relay

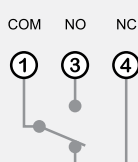

Transmitter

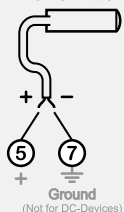

Receiver





1-channel amplifier ISG-N24 / ISG-N34

- Detection range up to 70 m
- Sensitivity adjustable with potentiometer
- Basic transmit level 2-fold selectable
- Switching behaviour light / dark selectable
- Transmit frequency 4-fold selectable
- Switching delay (only ISG-N34)
- Relay output, change over
- Transistor output, NPN / PNP
- Test input for system check

Technical data (at 20°C)

Operating voltage	see purchase order table
Operating basis	modulated infrared light
Transmit frequency	3.5 kHz / 3.8 kHz / 4.0 kHz / 4.4 kHz
Transmit power	manual
Basic transmit level	low / high
Switching behaviour	light / dark
Switching delay	0 ... 10 s (only ISG-N34)
Multiplex speed	—
Master/Slave operation	—
Switching output relay	change over
Operation values (max.)	5 A / 230 V AC (24 V DC)
Reaction time	36 ms
Switching output transistor	NPN / PNP
Operation values (max.) ...AC	NPN: 100 mA / 30 V DC PNP: 5 mA / 12 V DC
Operation values (max.) ...DC	NPN / PNP: 100 mA / 30 V DC
Reaction time	36 ms
Alarm output	—
Test input	24 V DC
Analog output	—
COM-Interface	—
Housing material	plastic
Protection class (EN 60529)	IP 40
Connection	11-pole DIN-plug
Operating temperature	-25 °C ... 50 °C
Dimensions (W x H x D)	40 x 76.5 x 80 mm see picture 10 on page 55

For more detailed information see www.pantron.com

Maximum Range (through beam)

	Receiver IRL...	Receiver IR...
Transmitter IT-..., ITL-...	20 m	25 m
Transmitter IT-...HP, ITH-...	30 m	35 m
Transmitter ITA-...	50 m	70 m

Connection diagram

Operating voltage

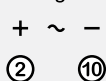

Relay

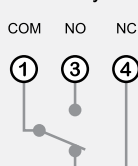

Transmitter

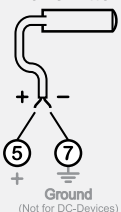

Receiver

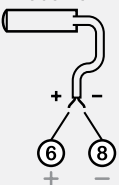

Transistor output

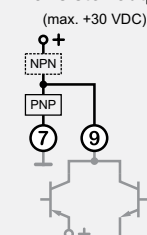

Test input



Purchase order table

Operation voltage	Order code	
230 V AC / ± 10% / 3.8 VA	ISG-N24/230VAC	ISG-N34/230VAC
115 V AC / ± 10% / 3.8 VA	ISG-N24/115VAC	ISG-N34/115VAC
24 V AC / ± 10% / 3.8 VA	ISG-N24/24VAC	ISG-N34/24VAC
24 V DC / ± 20% / 2.0 W	ISG-N24/24VDC	ISG-N34/24VDC
Accessories	Order code	Page
Protective enclosure	PanBox 1x1	78
11-pole DIN-socket	ISO1	85
Retaining clip	RTC 11	85

Device description

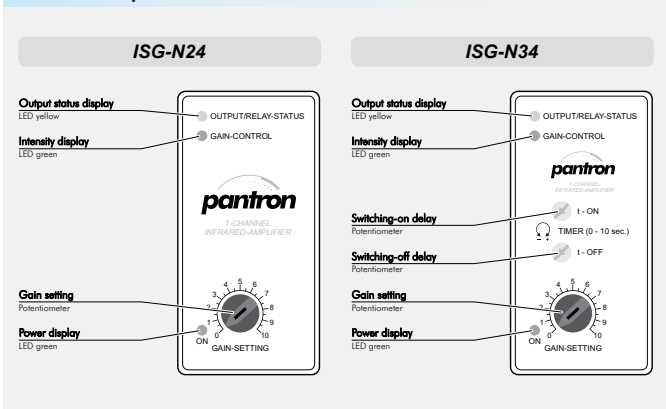

Amplifier mode (factory setting is marked white)

Basic transmit level	Switching behaviour		Transmit frequency	
	1	2	3	4
low	ON	dark	ON	ON
	OFF	light	OFF	OFF
high	OFF	light	OFF	ON
	ON	dark	ON	OFF

1-channel amplifier ISG-N27 / ISG-N37

- Detection range up to 70 m
- Sensitivity adjustable with potentiometer
- Basic transmit level 2-fold selectable
- Switching behaviour light / dark selectable
- Transmit frequency 4-fold selectable
- Switching delay (only ISG-N37)
- Relay output, change over
- Transistor output, NPN / PNP
- Alarm output for power limit



Purchase order table		
Operation voltage	Order code	
230 V AC / ± 10% / 3.8 VA	ISG-N27/230VAC	ISG-N37/230VAC
115 V AC / ± 10% / 3.8 VA	ISG-N27/115VAC	ISG-N37/115VAC
24 V AC / ± 10% / 3.8 VA	ISG-N27/24VAC	ISG-N37/24VAC
24 V DC / ± 20% / 2.0 W	ISG-N27/24VDC	ISG-N37/24VDC
Accessories	Order code	Page
Protective enclosure	PanBox 1x1	78
11-pole DIN-socket	ISO1	85
Retaining clip	RTC 11	85

Technical data (at 20°C)	
Operating voltage	see purchase order table
Operating basis	modulated infrared light
Transmit frequency	3.5 kHz / 3.8 kHz / 4.0 kHz / 4.4 kHz
Transmit power	manual
Basic transmit level	low / high
Switching behaviour	light / dark
Switching delay	0 ... 10 s (only ISG-N37)
Multiplex speed	—
Master/Slave operation	—
Switching output relay	change over
Operation values (max.)	5 A / 230 V AC (24 V DC)
Reaction time	36 ms
Switching output transistor	NPN / PNP
Operation values (max.) ...AC	NPN: 100 mA / 30 V DC PNP: 5 mA / 12 V DC
Operation values (max.) ...DC	100 mA / 30 V DC
Reaction time	36 ms
Alarm output	NPN / PNP
Operation values (max.) ...AC	NPN: 100 mA / 30 V DC PNP: 5 mA / 12 V DC
Operation values (max.) ...DC	NPN / PNP: 100 mA / 30 V DC
Test input	—
Analog output	—
COM-Interface	—
Housing material	plastic
Protection class (EN 60529)	IP 40
Connection	11-pole DIN-plug
Operating temperature	-25 °C ... 50 °C
Dimensions (W x H x D)	40 x 76.5 x 80 mm see picture 10 on page 55
For more detailed information see www.pantron.com	

Device description

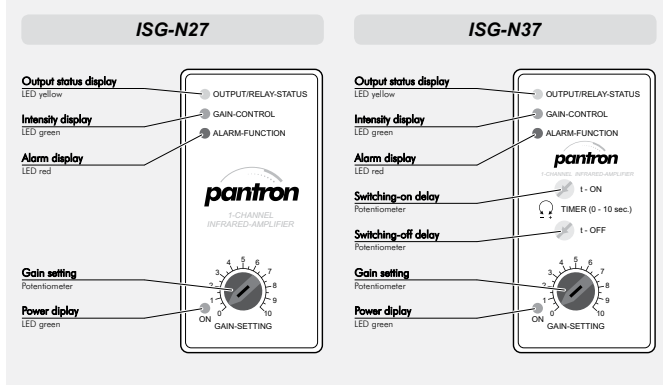

Amplifier mode (factory setting is marked white)

Basic transmit level	Switching behaviour		Transmit frequency	
	1	2	3	4
low	ON	dark	ON	ON
	OFF	light	ON	OFF
high	ON	dark	OFF	ON
	OFF	light	OFF	OFF

Maximum Range (through beam)

	Receiver IRL-...	Receiver IR-...
Transmitter IT-..., ITL-...	20 m	25 m
Transmitter IT-...HP, ITH-...	30 m	35 m
Transmitter ITA-...	50 m	70 m

Connection diagram

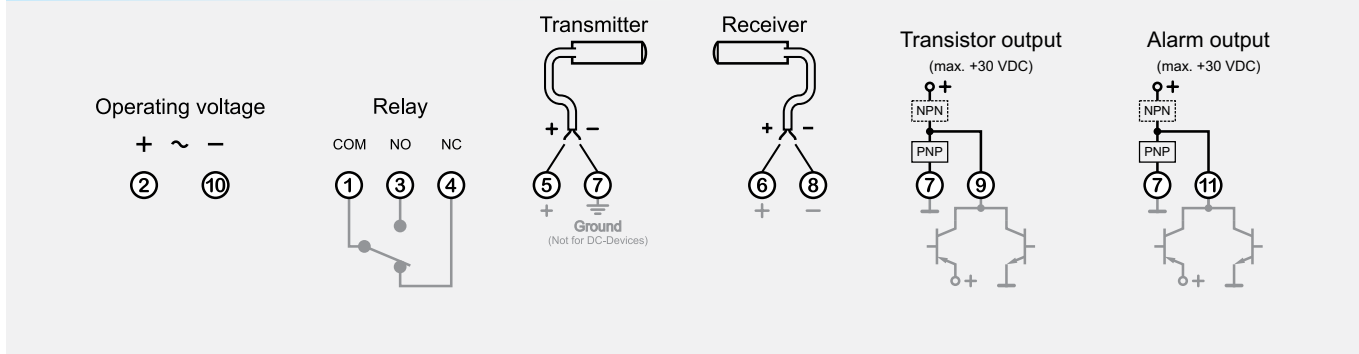



ISG-N127



ISG-N137

1-channel amplifier ISG-N127 / ISG-N137

- Detection range up to 55 m
- Sensitivity adjustable with potentiometer
- Sensor control
- Basic transmit level 2-fold selectable
- Switching behaviour light / dark selectable
- Transmit frequency 4-fold selectable
- Switching delay (only ISG-N137)
- Transistor output, NPN / PNP
- Alarm output

Technical data (at 20°C)

Operating voltage	see purchase order table	
Operating basis	modulated infrared light	
Transmit frequency	3.0 kHz / 3.3 kHz / 3.7 kHz / 4.0 kHz	
Transmit power	manual	
Basic transmit level	low / high	
Switching behaviour	light / dark	
Switching delay	0 ... 10 s (only ISG-N137)	
Multiplex speed	—	
Master/Slave operation	—	
Switching output relay	—	
Switching output transistor	NPN / PNP	
Operation values (max.)	100 mA / 30 V DC	
Reaction time	16 ms (Basic transmit level: low) 70 ms (Basic transmit level: high)	
Alarm output	...AC: NPN	...DC: NPN / PNP
Operation values (max.)	100 mA / 30 V DC	
Test input	—	
Analog output	—	
COM-Interface	—	
Housing material	plastic	
Protection class (EN 60529)	IP 40	
Connection	11-pole DIN-plug	
Operating temperature	-25 °C ... 50 °C	
Dimensions (W x H x D)	40 x 76.5 x 80 mm see picture 10 on page 55	

For more detailed information see www.pantron.com

Maximum Range (through beam)

	Receiver IRL-...	Receiver IR-...
Transmitter IT-..., ITL-...	10 m	20 m
Transmitter IT-...HP, ITH-...	20 m	35 m
Transmitter ITA-...	35 m	55 m

Connection diagram

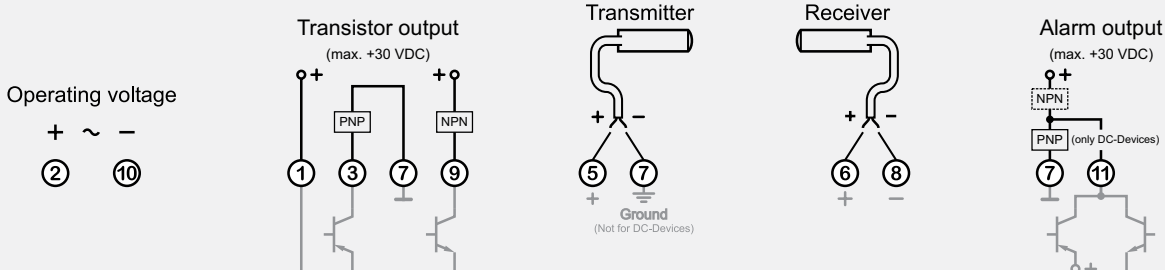

Purchase order table

Operation voltage	Order code	
230 V AC / ± 10% / 3.8 VA	ISG-N127/230VAC	ISG-N137/230VAC
115 V AC / ± 10% / 3.8 VA	ISG-N127/115VAC	ISG-N137/115VAC
24 V AC / ± 10% / 3.8 VA	ISG-N127/24VAC	ISG-N137/24VAC
24 V DC / ± 20% / 2.0 W	ISG-N127/24VDC	ISG-N137/24VDC
Accessories	Order code	Page
Protective enclosure	PanBox 1x1	78
11-pole DIN-socket	ISO1	85
Retaining clip	RTC 11	85

Device description

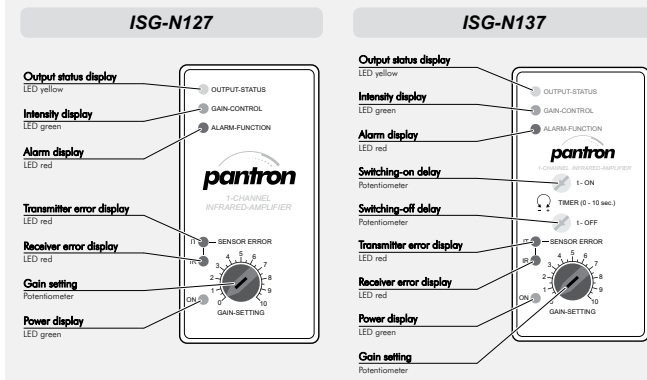

Amplifier mode (factory setting is marked white)

Basic transmit level	Switching behaviour		Transmit frequency	
	1	2	3	4
low	ON	dark	ON	ON
	OFF	light	OFF	OFF
high	ON	dark	ON	ON
	OFF	light	OFF	OFF

1-channel amplifier ISG-N128 / ISG-N138

- Detection range up to 55 m
- Sensitivity adjustable with potentiometer
- Sensor control
- Basic transmit level 2-fold selectable
- Switching behaviour light / dark selectable
- Transmit frequency 4-fold selectable
- Switching delay (only ISG-N138)
- Relay output, change over
- Transistor output, NPN
- Alarm output



Purchase order table		
Operation voltage	Order code	
230 V AC / ± 10% / 3.8 VA	ISG-N128/230VAC	ISG-N138/230VAC
115 V AC / ± 10% / 3.8 VA	ISG-N128/115VAC	ISG-N138/115VAC
24 V AC / ± 10% / 3.8 VA	ISG-N128/24VAC	ISG-N138/24VAC
24 V DC / ± 20% / 2.0 W	ISG-N128/24VDC	ISG-N138/24VDC
Accessories	Order code	Page
Protective enclosure	PanBox 1x1	78
11-pole DIN-socket	ISO1	85
Retaining clip	RTC 11	85

Technical data (at 20°C)	
Operating voltage	see purchase order table
Operating basis	modulated infrared light
Transmit frequency	3.0 kHz / 3.3 kHz / 3.7 kHz / 4.0 kHz
Transmit power	manual
Basic transmit level	low / high
Switching behaviour	light / dark
Switching delay	0 ... 10 s (only ISG-N138)
Multiplex speed	—
Master/Slave operation	—
Switching output relay	change over
Operation values (max.)	5 A / 230 V AC (24 V DC)
Reaction time	16 ms (Basic transmit level: low) 70 ms (Basic transmit level: high)
Switching output transistor	NPN
Operation values (max.)	100 mA / 30 V DC
Reaction time	16 ms (Basic transmit level: low) 70 ms (Basic transmit level: high)
Alarm output	...AC: NPN ...DC: NPN / PNP
Operation values (max.)	100 mA / 30 V DC
Test input	—
Analog output	—
COM-Interface	—
Housing material	plastic
Protection class (EN 60529)	IP 40
Connection	11-pole DIN-plug
Operating temperature	-25 °C ... 50 °C
Dimensions (W x H x D)	40 x 76.5 x 80 mm see picture 10 on page 55
For more detailed information see www.pantron.com	

Device description

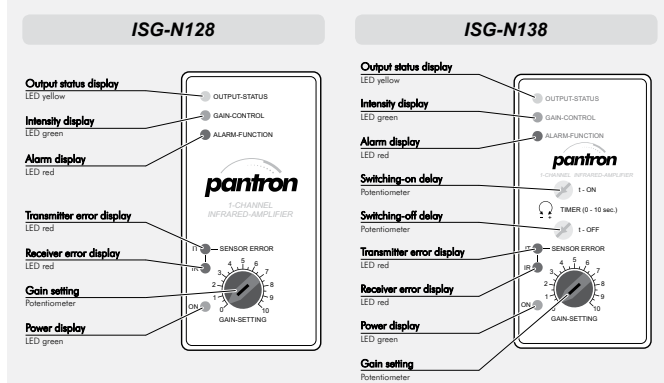

Amplifier mode (factory setting is marked white)

Basic transmit level	Switching behaviour		Transmit frequency	
	1	2	3	4
low	ON	dark	ON	ON
	OFF	light	OFF	OFF
high	ON	dark	ON	ON
	OFF	light	OFF	OFF

Maximum Range (through beam)

	Receiver IRL-...	Receiver IR-...
Transmitter IT-..., ITL-...	10 m	20 m
Transmitter IT-...HP, ITH-...	20 m	35 m
Transmitter ITA-...	35 m	55 m

Connection diagram

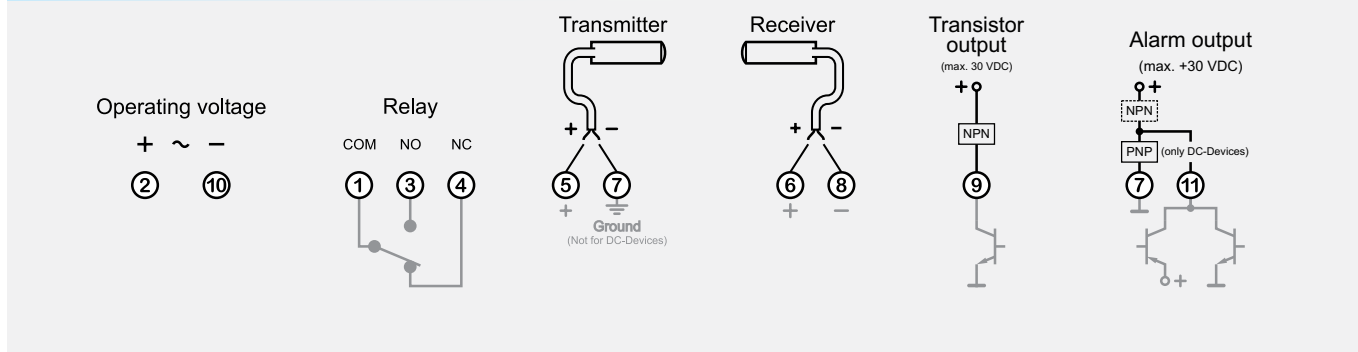



1-channel automatic amplifier ISG-A113 / ISG-A114

- Detection range up to 50 m
- Automatic transmit power adjustment
- Basic transmit level 2-fold selectable
- Switching output (**ISG-A113** with transistor output and **ISG-A114** with relay output)
- Alarm output

Technical data (at 20°C)

Operating voltage	see purchase order table
Operating basis	modulated infrared light
Transmit frequency	3.9 kHz
Transmit power	automatic
Basic transmit level	low1 / low2
Switching behaviour	light
Switching delay	—
Multiplex speed	—
Master/Slave operation	—
Teach function	—
Switching output ISG-A113	transistor, NPN / PNP
Operation values (max.)	100 mA / 30 V DC
Reaction time	25 ms
Switching output ISG-A114	relay, change over
Operation values (max.)	5 A / 230 V AC (24 V DC)
Reaction time	25 ms
Alarm output	PNP
Operation values (max.) ...AC	5 mA / 24 V DC
Operation values (max.) ...DC	100 mA / 24 V DC
Test input	—
Analog output	—
COM-Interface	—
Housing material	plastic
Protection class (EN 60529)	IP 40
Connection	11-pole DIN-plug
Operating temperature	-25 °C ... 50 °C
Dimensions (W x H x D)	40 x 76.5 x 78.5 mm see picture 11 on page 56
For more detailed information see www.pantron.com	

Maximum Range (through beam)

	Receiver IRL-...	Receiver IR-...
Transmitter IT-..., ITL-...	7 m	15 m
Transmitter IT-...HP, ITH-...	10 m	25 m
Transmitter ITA-...	20 m	50 m

Connection diagram

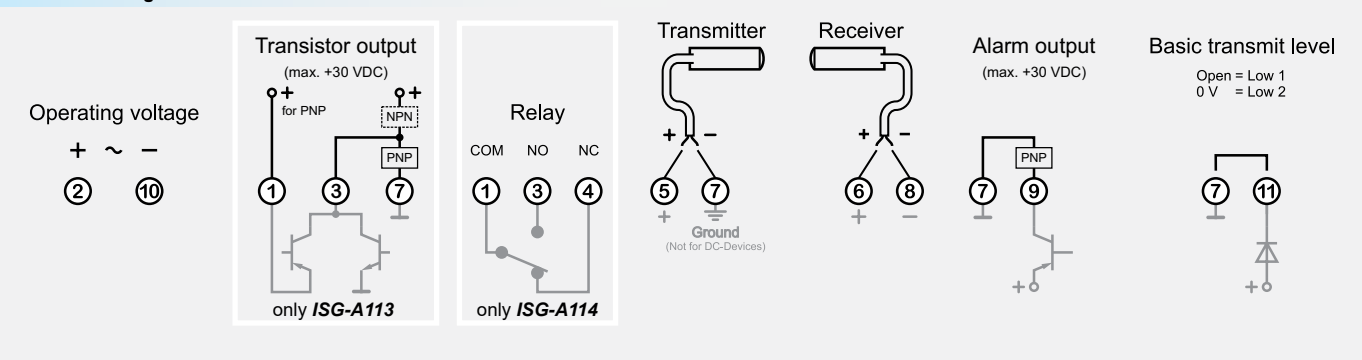

Purchase order table

Operation voltage	Order code	
230 V AC / ± 10% / 4.1 VA	ISG-A113/230VAC	ISG-A114/230VAC
115 V AC / ± 10% / 4.1 VA	ISG-A113/115VAC	ISG-A114/115VAC
24 V AC / ± 10% / 4.1 VA	ISG-A113/24VAC	ISG-A114/24VAC
24 V DC / ± 20% / 1.9 W	ISG-A113/24VDC	ISG-A114/24VDC
Accessories	Order code	Page
Protective enclosure	PanBox 1x1	78
11-pole DIN-socket	ISO1	85
Retaining clip	RTC 11	85

Device description

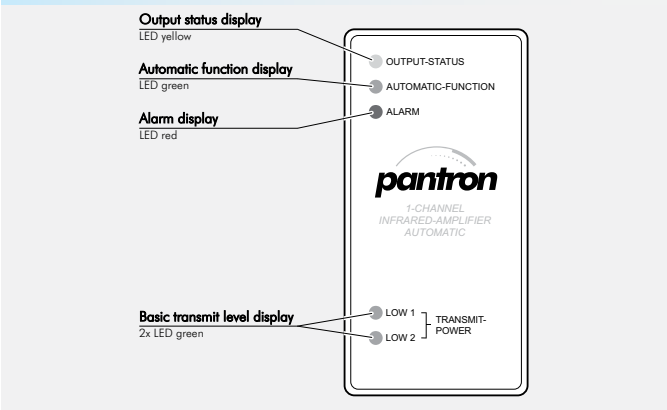

1-channel automatic amplifier ISG-A123 / ISG-A124

- Detection range up to 50 m
- Automatic transmit power adjustment
- Test function
- Basic transmit level 4-fold selectable
- Switching behaviour light / dark selectable
- Transmit frequency 4-fold selectable
- Switching output (**ISG-A123** with transistor output and **ISG-A124** with relay output)
- Alarm output
- Test input for system check



Purchase order table

Operation voltage	Order code	
230 V AC / ± 10% / 4.1 VA	ISG-A123/230VAC	ISG-A124/230VAC
115 V AC / ± 10% / 4.1 VA	ISG-A123/115VAC	ISG-A124/115VAC
24 V AC / ± 10% / 4.1 VA	ISG-A123/24VAC	ISG-A124/24VAC
24 V DC / ± 20% / 1.9 W	ISG-A123/24VDC	ISG-A124/24VDC
Accessories	Order code	Page
Protective enclosure	PanBox 1x1	78
11-pole DIN-socket	ISO1	85
Retaining clip	RTC 11	85

Device description

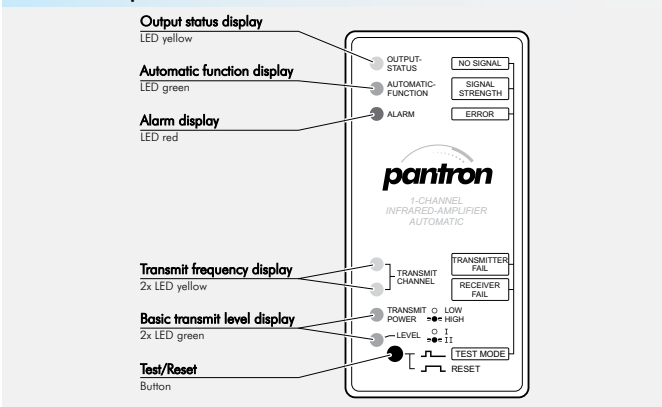

Amplifier mode (factory setting is marked white)

ON 1 2 3 4	Basic transmit level		Switching behaviour		Transmit frequency	
	1	2	3	4	4	4
high2	ON	ON	dark	ON	4.1 kHz	ON
high1	ON	OFF	light	OFF	3.7 kHz	OFF
low2	OFF	ON	light	OFF	3.7 kHz	OFF
low1	OFF	OFF	light	OFF	3.7 kHz	OFF

Technical data (at 20°C)

Operating voltage	see purchase order table
Operating basis	modulated infrared light
Transmit frequency	3.7 kHz / 4.1 kHz
Transmit power	automatic
Basic transmit level	low1 / low2 / high1 / high2
Switching behaviour	light / dark
Switching delay	—
Multiplex speed	—
Master/Slave operation	—
Teach function	—
Switching output ISG-A123	transistor, NPN / PNP
Operation values (max.)	100 mA / 30 V DC
Reaction time	25 ms / 52 ms (Basic transmit level: low / high)
Switching output ISG-A124	relay, change over
Operation values (max.)	5 A / 230 V AC (24 V DC)
Reaction time	25 ms / 52 ms (Basic transmit level: low / high)
Alarm output	PNP
Operation values (max.) ...AC	5 mA / 24 V DC
Operation values (max.) ...DC	100 mA / 24 V DC
Test input	0 ... 30 V DC
Analog output	—
COM-Interface	—
Housing material	plastic
Protection class (EN 60529)	IP 40
Connection	11-pole DIN-plug
Operating temperature	-25 °C ... 50 °C
Dimensions (W x H x D)	40 x 76.5 x 78.5 mm see picture 12 on page 56
For more detailed information see www.pantron.com	

Maximum Range (through beam)

	Receiver IRL-...	Receiver IR-...
Transmitter IT-..., ITL-...	7 m	15 m
Transmitter IT-...HP, ITH-...	10 m	25 m
Transmitter ITA-...	20 m	50 m

Connection diagram

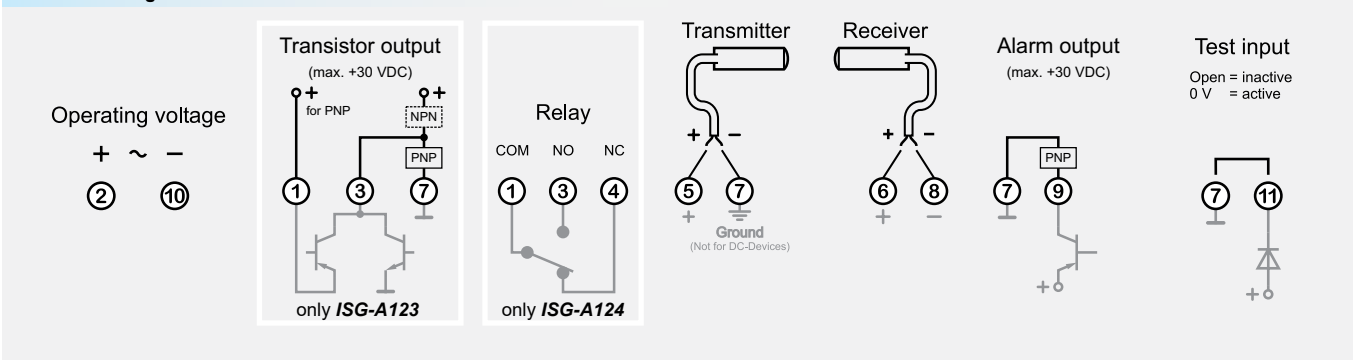



1-channel automatic amplifier ISG-A133 / ISG-A134

- Detection range up to 50 m
- Automatic transmit power adjustment
- Test function
- Basic transmit level 4-fold selectable
- Switching behaviour light / dark selectable
- Transmit frequency 4-fold selectable
- Switching delay 0 ... 10 s (**ISG-A134** also available with switching delay 0 ... 1 s: order code **ISG-A105**)
- Switching output (**ISG-A133** with transistor output and **ISG-A134** with relay output)
- Alarm output
- Test input for system check

Technical data (at 20°C)

Operating voltage	see purchase order table
Operating basis	modulated infrared light
Transmit frequency	3.7 kHz / 4.1 kHz
Transmit power	automatic
Basic transmit level	low1 / low2 / high1 / high2
Switching behaviour	light / dark
Switching delay	0 ... 10 s
Multiplex speed	—
Master/Slave operation	—
Teach function	—
Switching output ISG-A133	transistor, NPN / PNP
Operation values (max.)	100 mA / 30 V DC
Reaction time	25 ms / 52 ms (Basic transmit level: low / high)
Switching output ISG-A134	relay, change over
Operation values (max.)	5 A / 230 V AC (24 V DC)
Reaction time	25 ms / 52 ms (Basic transmit level: low / high)
Alarm output	PNP
Operation values (max.) ...AC	5 mA / 24 V DC
Operation values (max.) ...DC	100 mA / 24 V DC
Test input	0 ... 30 V DC
Analog output	—
COM-Interface	—
Housing material	plastic
Protection class (EN 60529)	IP 40
Connection	11-pole DIN-plug
Operating temperature	-25 °C ... 50 °C
Dimensions (W x H x D)	40 x 76.5 x 78.5 mm see picture 12 on page 56

For more detailed information see www.pantron.com

Maximum Range (through beam)

	Receiver IRL-...	Receiver IR-...
Transmitter IT-..., ITL-...	7 m	15 m
Transmitter IT-...HP, ITH-...	10 m	25 m
Transmitter ITA-...	20 m	50 m

Connection diagram

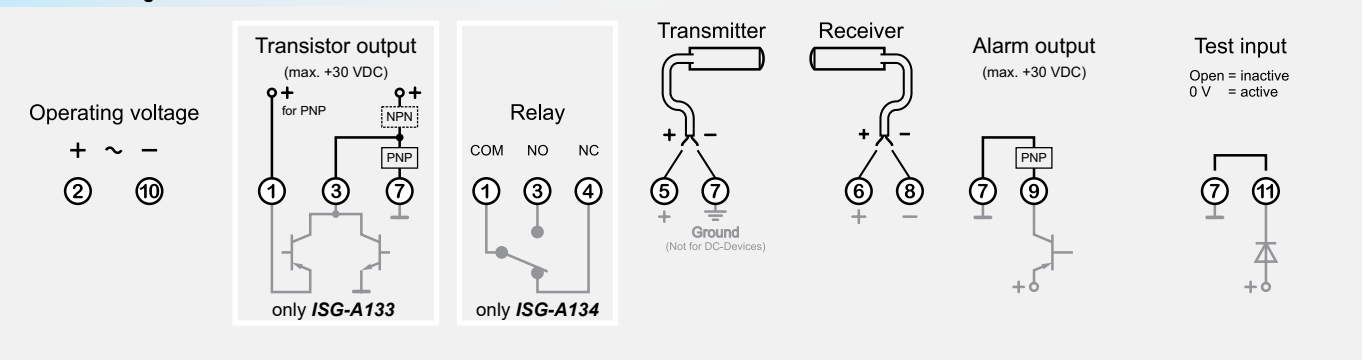

Purchase order table

Operation voltage	Order code	
230 V AC / ± 10% / 4.1 VA	ISG-A133/230VAC	ISG-A134/230VAC
115 V AC / ± 10% / 4.1 VA	ISG-A133/115VAC	ISG-A134/115VAC
24 V AC / ± 10% / 4.1 VA	ISG-A133/24VAC	ISG-A134/24VAC
24 V DC / ± 20% / 1.9 W	ISG-A133/24VDC	ISG-A134/24VDC
Accessories	Order code	Page
Protective enclosure	PanBox 1x1	78
11-pole DIN-socket	ISO1	85
Retaining clip	RTC 11	85

Device description

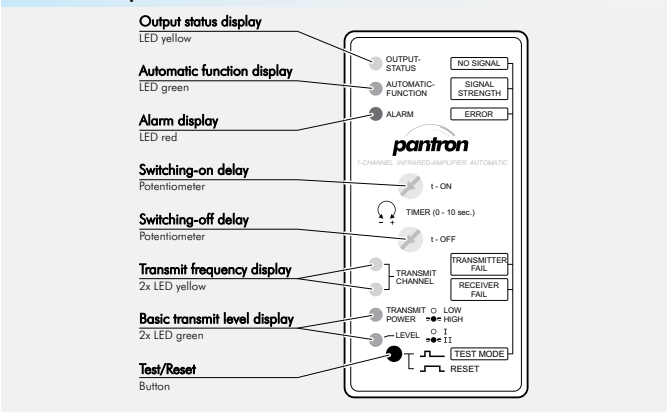

Amplifier mode (factory setting is marked white)

ON	Basic transmit level		Switching behaviour		Transmit frequency	
	1	2	3	4	1	2
high2	ON	ON	dark	ON	4.1 kHz	ON
high1	ON	OFF				
low2	OFF	ON	light	OFF	3.7 kHz	OFF
low1	OFF	OFF				

1-channel automatic amplifier ISG-A143 / ISG-A144

- Detection range up to 50 m
- Automatic transmit power adjustment
- Teach function
- Test function
- Basic transmit level 2-fold selectable
- Switching behaviour light / dark selectable
- Transmit frequency 2-fold selectable
- Switching output (**ISG-A143** with transistor output and **ISG-A144** with relay output)
- Alarm output
- Test input for system check



Purchase order table

Operation voltage	Order code	
230 V AC / ± 10% / 4.1 VA	ISG-A143/230VAC	ISG-A144/230VAC
115 V AC / ± 10% / 4.1 VA	ISG-A143/115VAC	ISG-A144/115VAC
24 V AC / ± 10% / 4.1 VA	ISG-A143/24VAC	ISG-A144/24VAC
24 V DC / ± 20% / 1.9 W	ISG-A143/24VDC	ISG-A144/24VDC
Accessories	Order code	Page
Protective enclosure	PanBox 1x1	78
11-pole DIN-socket	ISO1	85
Retaining clip	RTC 11	85

Technical data (at 20°C)

Operating voltage	see purchase order table
Operating basis	modulated infrared light
Transmit frequency	3.7 kHz / 4.1 kHz
Transmit power	automatic
Basic transmit level	low1 / low2
Switching behaviour	light / dark
Switching delay	—
Multiplex speed	—
Master/Slave operation	—
Teach function	teach1 / teach2
Switching output relay	—
Switching output ISG-A143	transistor, NPN / PNP
Operation values (max.)	100 mA / 30 V DC
Reaction time	25 ms
Switching output ISG-A144	relay, change over
Operation values (max.)	5 A / 230 V AC (24 V DC)
Reaction time	25 ms
Alarm output	PNP
Operation values (max.) ...AC	5 mA / 24 V DC
Operation values (max.) ...DC	100 mA / 24 V DC
Test input	0 ... 30 V DC
Analog output	—
COM-Interface	—
Housing material	plastic
Protection class (EN 60529)	IP 40
Connection	11-pole DIN-plug
Operating temperature	-25 °C ... 50 °C
Dimensions (W x H x D)	40 x 76.5 x 78.5 mm see picture 12 on page 56

Device description



Amplifier mode (factory setting is marked white)

ON	Operation mode		Switching behaviour		Transmit frequency	
	1	2	3	4	5	6
teach2	ON	ON	dark	ON	4.1 kHz	ON
teach1	ON	OFF	light	OFF	3.7 kHz	OFF
low2	OFF	ON	light	OFF	3.7 kHz	OFF
low1	OFF	OFF	light	OFF	3.7 kHz	OFF

Maximum Range (through beam)

	Receiver IRL-...	Receiver IR-...
Transmitter IT-..., ITL-...	7 m	15 m
Transmitter IT-...HP, ITH-...	10 m	25 m
Transmitter ITA-...	20 m	50 m

Connection diagram

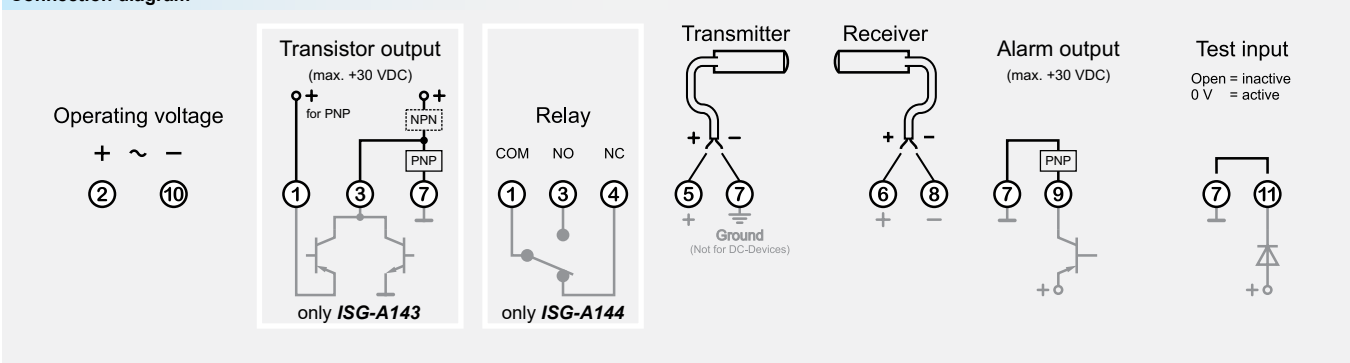



2-channel multiplex amplifier IMX-N23 / IMX-N24

- Detection range up to 50 m
- Sensitivity adjustable with potentiometer
- Basic transmit level 2-fold selectable
- Switching behaviour light / dark selectable
- Multiplex speed 2-fold selectable
- Switching output (*IMX-N23* with transistor output and *IMX-N24* with relay output)

Technical data (at 20°C)

Operating voltage	see purchase order table
Operating basis	modulated infrared light
Transmit frequency	4.0 kHz
Transmit power	manual
Basic transmit level	low / high
Switching behaviour	light / dark
Switching delay	—
Multiplex speed	8 ms / 16 ms
Light curtain	—
Master/Slave operation	—
Switching output IMX-N23	2x transistor, NPN / PNP
Operation values (max.)	30 mA / 30 V DC
Reaction time	16 ms (Multiplex speed: 8 ms) 32 ms (Multiplex speed: 16 ms)
Switching output IMX-N24	2x relay, normally open
Operation values (max.)	5 A / 230 V AC (24 V DC)
Reaction time	16 ms (Multiplex speed: 8 ms) 32 ms (Multiplex speed: 16 ms)
Alarm output	—
Test input	—
Analog output	—
COM-Interface	—
Housing material	plastic
Protection class (EN 60529)	IP 40
Connection	11-pole DIN-plug
Operating temperature	-25 °C ... 50 °C
Dimensions (W x H x D)	40 x 76.5 x 78.5 mm see picture 12 on page 56

For more detailed information see www.pantron.com

Maximum Range (through beam)

	Receiver IRL-...	Receiver IR-...
Transmitter IT-..., ITL-...	10 m	20 m
Transmitter IT-...HP, ITH-...	15 m	30 m
Transmitter ITA-...	25 m	50 m

Connection diagram

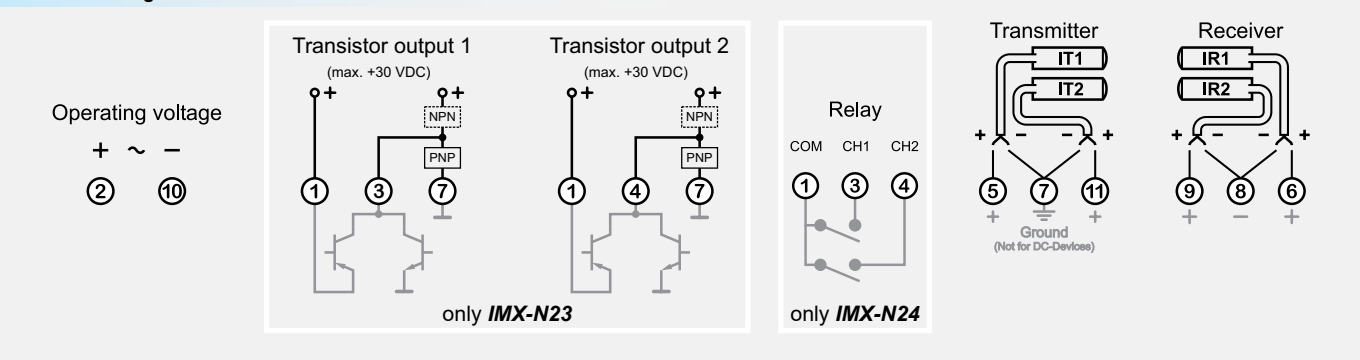

Purchase order table

Operation voltage	Order code	
230 V AC / ± 10% / 4.4 VA	IMX-N23/230VAC	IMX-N24/230VAC
115 V AC / ± 10% / 4.4 VA	IMX-N23/115VAC	IMX-N24/115VAC
24 V AC / ± 10% / 4.4 VA	IMX-N23/24VAC	IMX-N24/24VAC
24 V DC / ± 20% / 2.3 W	IMX-N23/24VDC	IMX-N24/24VDC
Accessories	Order code	Page
Protective enclosure	PanBox 1x2	78
11-pole DIN-socket	ISO1	85
Retaining clip	RTC 11	85

Device description

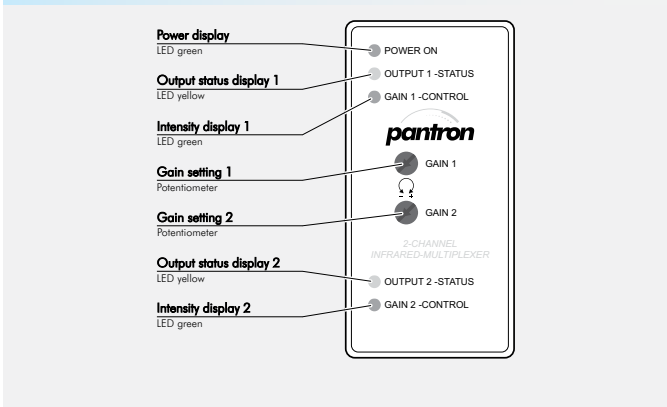

Amplifier mode (factory setting is marked white)

ON 1 2 3 4	Switching behaviour		Basic transmit level		Multiplex speed		
	channel 1	channel 2	1	2	3	4	
dark	ON	dark	ON	high	ON	16 ms	ON
light	OFF	light	OFF	low	OFF	8 ms	OFF

2-channel multiplex amplifier IMX-N33 / IMX-N34

- Detection range up to 50 m
- Sensitivity adjustable with potentiometer
- Basic transmit level 2-fold selectable
- Switching behaviour light / dark selectable
- Multiplex speed 2-fold selectable
- Switching delay
- Switching output (*IMX-N33* with transistor output and *IMX-N34* with relay output)



Purchase order table

Operation voltage	Order code	
230 V AC / ± 10% / 4.4 VA	IMX-N33/230VAC	IMX-N34/230VAC
115 V AC / ± 10% / 4.4 VA	IMX-N33/115VAC	IMX-N34/115VAC
24 V AC / ± 10% / 4.4 VA	IMX-N33/24VAC	IMX-N34/24VAC
24 V DC / ± 20% / 2.3 W	IMX-N33/24VDC	IMX-N34/24VDC
Accessories	Order code	Page
Protective enclosure	PanBox 1x2	78
11-pole DIN-socket	ISO1	85
Retaining clip	RTC 11	85

Technical data (at 20°C)

Operating voltage	see purchase order table
Operating basis	modulated infrared light
Transmit frequency	4.0 kHz
Transmit power	manual
Basic transmit level	low / high
Switching behaviour	light / dark
Switching delay	0 ... 15 s
Multiplex speed	8 ms / 16 ms
Light curtain	—
Master/Slave operation	—
Switching output <i>IMX-N33</i>	2x transistor, NPN / PNP
Operation values (max.)	30 mA / 30 V DC
Reaction time	16 ms (Multiplex speed: 8 ms) 32 ms (Multiplex speed: 16 ms)
Switching output <i>IMX-N34</i>	2x relay, normally open
Operation values (max.)	5 A / 230 V AC (24 V DC)
Reaction time	16 ms (Multiplex speed: 8 ms) 32 ms (Multiplex speed: 16 ms)
Alarm output	—
Test input	—
Analog output	—
COM-Interface	—
Housing material	plastic
Protection class (EN 60529)	IP 40
Connection	11-pole DIN-plug
Operating temperature	-25 °C ... 50 °C
Dimensions (W x H x D)	40 x 76.5 x 78.5 mm see picture 12 on page 56
For more detailed information see www.pantron.com	

Device description

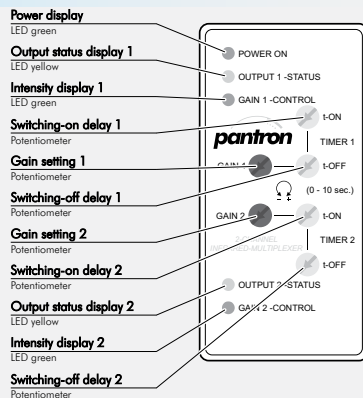

Amplifier mode (factory setting is marked white)

ON 1 2 3 4	Switching behaviour		Basic transmit level		Multiplex speed		
	channel 1	channel 2	1	2	3	4	
dark	ON	dark	ON	high	ON	16 ms	ON
light	OFF	light	OFF	low	OFF	8 ms	OFF

Maximum Range (through beam)

	Receiver IRL-...	Receiver IR-...
Transmitter IT-..., ITL-...	10 m	20 m
Transmitter IT-...HP, ITH-...	15 m	30 m
Transmitter ITA-...	25 m	50 m

Connection diagram

Operating voltage

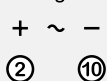

Transistor output 1

(max. +30 VDC)

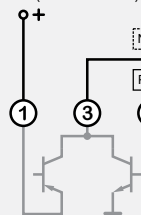

only *IMX-N33*...

Transistor output 2

(max. +30 VDC)

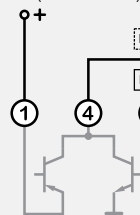

Relay



only *IMX-N34*

Transmitter

IT1 IT2

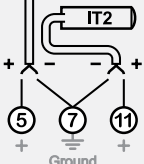

Receiver

IR1 IR2

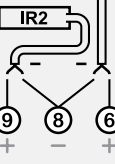

Ground (Not for DC-Devices)



4-channel multiplex amplifier IMX-N430

- Detection range up to 40 m
- Sensitivity adjustable with potentiometer
- Basic transmit level 2-fold selectable
- Switching behaviour light / dark selectable
- Multiplex speed 2-fold selectable
- Switching delay for channel 1
- Transistor output, NPN / PNP
- Master/Slave operation
- Mounting for DIN rail (EN 60715)

Technical data (at 20°C)

Operating voltage	see purchase order table
Operating basis	modulated infrared light
Transmit frequency	4.0 kHz
Transmit power	manual
Basic transmit level	low / high
Switching behaviour	light / dark
Switching delay	0 ... 15 s
Multiplex speed	16 ms / 32 ms
Light curtain	yes
Master/Slave operation	yes
Switching output	4x transistor, NPN / PNP
Operation values (max.)	20 mA / 24 V DC
Reaction time	18 ms
Alarm output	—
Test input	—
Analog output	—
COM-Interface	—
Housing material	plastic
Protection class (EN 60529)	IP 20
Connection	screw terminals
Operating temperature	-25 °C ... 50 °C
Dimensions (W x H x D)	100 x 75 x 110 mm see picture 14 on page 56

For more detailed information see www.pantron.com

Maximum Range (through beam)

	Receiver IRL-...	Receiver IR-...
Transmitter IT-..., ITL-...	10 m	20 m
Transmitter IT-...HP, ITH-...	15 m	30 m
Transmitter ITA-...	20 m	40 m

Connection diagram

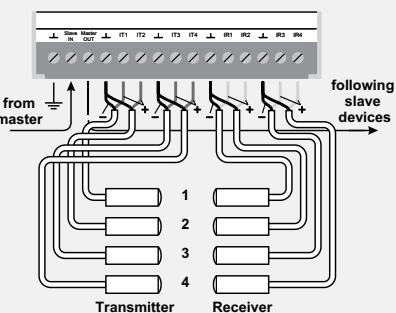
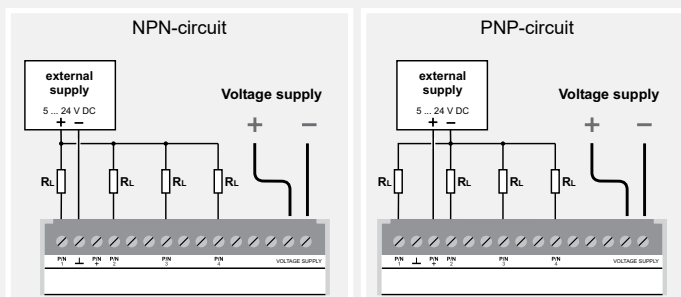

Purchase order table

Operation voltage	Order code
230 V AC / ± 10% / 8.2 VA	IMX-N430/230VAC
115 V AC / ± 10% / 8.2 VA	IMX-N430/115VAC
24 V AC / ± 10% / 8.2 VA	IMX-N430/24VAC
24 V DC / ± 20% / 4.3 W	IMX-N430/24VDC

Accessories	Order code	Page
Protective enclosure	PanBox 1x4	79

Device description

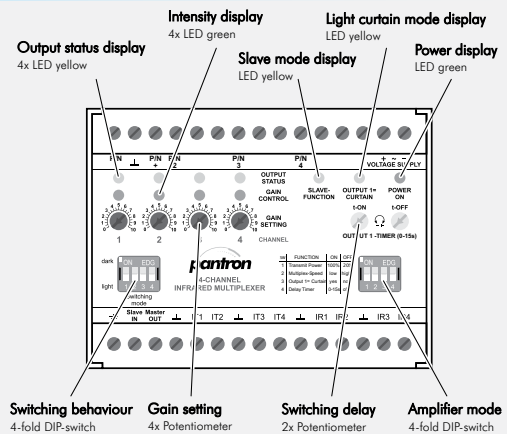

Amplifier mode (factory setting is marked white)

Basic transmit level	Multiplex speed		Light curtain		Switching delay	
	1	2	3	4	1	2
high	ON	32 ms	ON	ON	on	ON
low	OFF	16 ms	OFF	OFF	off	OFF

4-channel multiplex amplifier **IMX-N440**

- Detection range up to 40 m
- Sensitivity adjustable with potentiometer
- Basic transmit level 2-fold selectable
- Switching behaviour light / dark selectable
- Multiplex speed 2-fold selectable
- Switching delay for channel 1
- Relay output, change over
- Master/Slave operation
- Mounting for DIN rail (EN 60715)



Purchase order table		
Operation voltage	Order code	
230 V AC / ± 10% / 8.2 VA	IMX-N440/230VAC	
115 V AC / ± 10% / 8.2 VA	IMX-N440/115VAC	
24 V AC / ± 10% / 8.2 VA	IMX-N440/24VAC	
24 V DC / ± 20% / 4.3 W	IMX-N440/24VDC	
Accessories	Order code	Page
Protective enclosure	PanBox 1x4	79

Device description

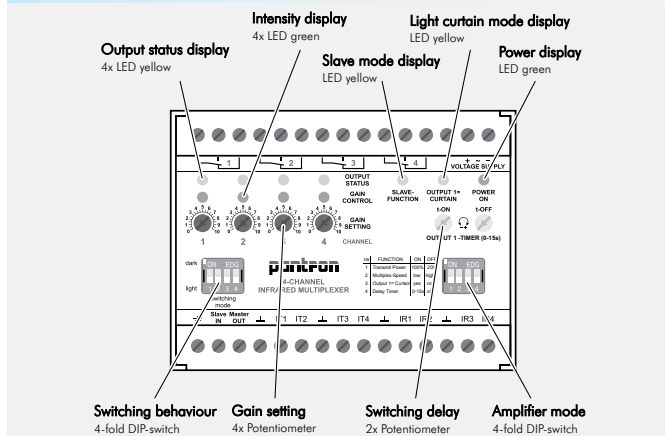

Technical data (at 20°C)	
Operating voltage	see purchase order table
Operating basis	modulated infrared light
Transmit frequency	4.0 kHz
Transmit power	manual
Basic transmit level	low / high
Switching behaviour	light / dark
Switching delay	0 ... 15 s
Multiplex speed	16 ms / 32 ms
Light curtain	yes
Master/Slave operation	yes
Switching output	4x relay, change over
Operation values (max.)	5 A / 230 V AC (24 V DC)
Reaction time	25 ms
Alarm output	—
Test input	—
Analog output	—
COM-Interface	—
Housing material	plastic
Protection class (EN 60529)	IP 20
Connection	screw terminals
Operating temperature	-25 °C ... 50 °C
Dimensions (W x H x D)	100 x 75 x 110 mm see picture 14 on page 56

Amplifier mode (factory setting is marked white)

ON 1 2 3 4	Basic transmit level		Multiplex speed		Light curtain		Switching delay	
	1	2	3	4	1	2	3	4
high	ON	32 ms	ON	ON	ON	ON	ON	ON
low	OFF	16 ms	OFF	OFF	OFF	OFF	OFF	OFF

For more detailed information see www.pantron.com

Maximum Range (through beam)	Receiver IRL-...	Receiver IR-...
	Transmitter IT-..., ITL-...	10 m
Transmitter IT-...HP, ITH-...	15 m	30 m
Transmitter ITA-...	20 m	40 m

Connection diagram

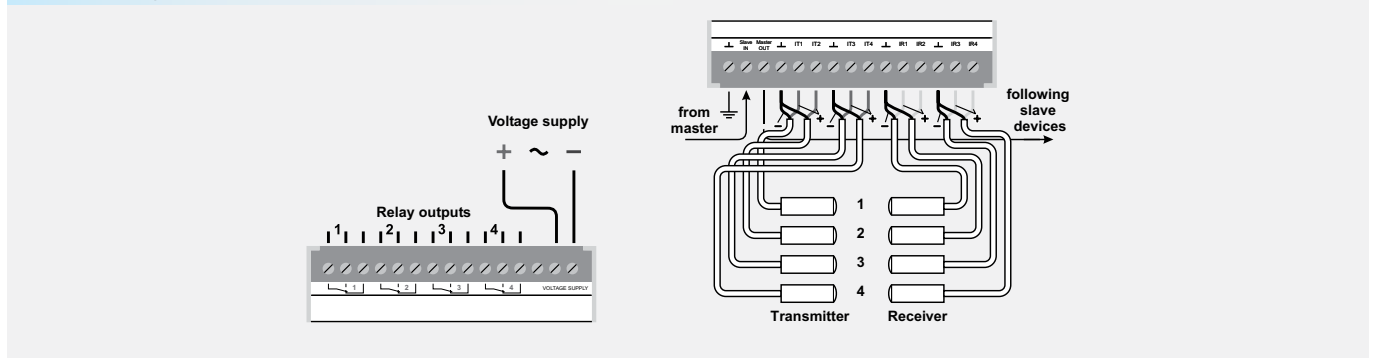



8-channel multiplex amplifier IMX-N830

- Detection range up to 40 m
- Sensitivity adjustable with potentiometer
- Basic transmit level 2-fold selectable
- Switching behaviour light / dark selectable
- Multiplex speed 2-fold selectable
- Switching delay for channel 1
- Transistor output, NPN / PNP
- Master/Slave operation
- Mounting for DIN rail (EN 60715)

Technical data (at 20°C)

Operating voltage	see purchase order table
Operating basis	modulated infrared light
Transmit frequency	4.0 kHz
Transmit power	manual
Basic transmit level	low / high
Switching behaviour	light / dark
Switching delay	0 ... 15 s
Multiplex speed	34 ms / 68 ms
Light curtain	yes
Master/Slave operation	yes
Switching output	8x transistor, NPN /PNP
Operation values (max.)	100 mA / 24 V DC
Reaction time	34 ms (Multiplex speed: 34 ms) 68 ms (Multiplex speed: 68 ms)
Alarm output	—
Test input	—
Analog output	—
COM-Interface	—
Housing material	plastic
Protection class (EN 60529)	IP 20
Connection	screw terminals
Operating temperature	-25 °C ... 50 °C
Dimensions (W x H x D)	149 x 75 x 110 mm see picture 15 on page 56

For more detailed information see www.pantron.com

Maximum Range (through beam)

	Receiver IRL-...	Receiver IR-...
Transmitter IT-..., ITL-...	10 m	20 m
Transmitter IT-...HP, ITH-...	15 m	30 m
Transmitter ITA-...	20 m	40 m

Connection diagram

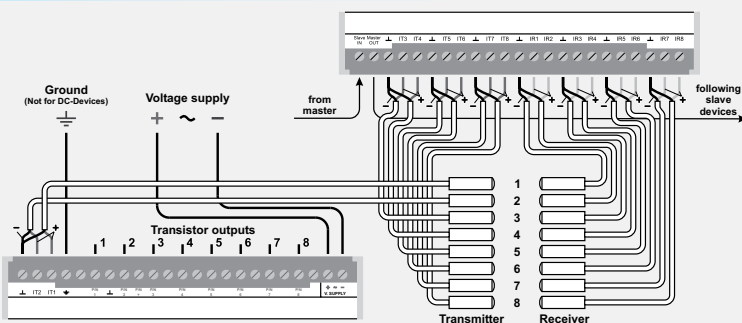

Purchase order table

Operation voltage	Order code
230 V AC / ± 10% / 10.2 VA	IMX-N830/230VAC
115 V AC / ± 10% / 10.2 VA	IMX-N830/115VAC
24 V AC / ± 10% / 10.2 VA	IMX-N830/24VAC
24 V DC / ± 20% / 5.7 W	IMX-N830/24VDC

Accessories	Order code	Page
Protective enclosure	PanBox 1x8	79

Device description

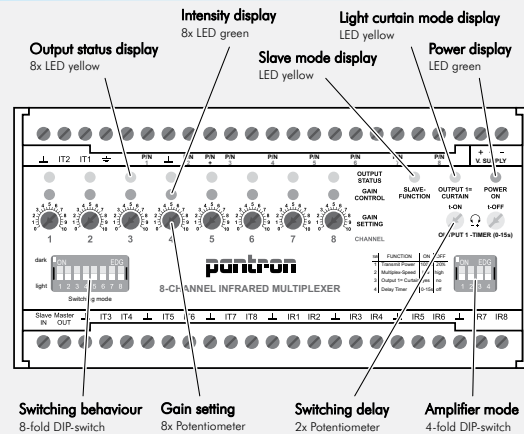

Amplifier mode (factory setting is marked white)

ON	Basic transmit level		Multiplex speed		Light curtain		Switching delay	
	1	2	3	4	5	6	7	8
high	ON	68 ms	ON	on	ON	on	ON	ON
low	OFF	34 ms	OFF	off	OFF	off	OFF	OFF

NPN-circuit

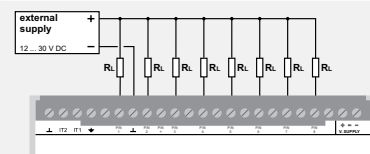

PNP-circuit

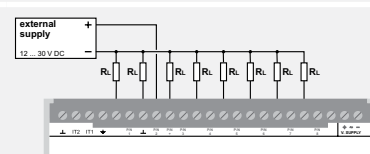

8-channel multiplex amplifier IMX-N840

- Detection range up to 40 m
- Sensitivity adjustable with potentiometer
- Basic transmit level 2-fold selectable
- Switching behaviour light / dark selectable
- Multiplex speed 2-fold selectable
- Switching delay for channel 1
- Relay output, normally open
- Master/Slave operation
- Mounting for DIN rail (EN 60715)



Purchase order table		
Operation voltage	Order code	
230 V AC / ± 10% / 10.2 VA	IMX-N840/230VAC	
115 V AC / ± 10% / 10.2 VA	IMX-N840/115VAC	
24 V AC / ± 10% / 10.2 VA	IMX-N840/24VAC	
24 V DC / ± 20% / 5.7 W	IMX-N840/24VDC	
Accessories	Order code	Page
Protective enclosure	PanBox 1x8	79

Device description

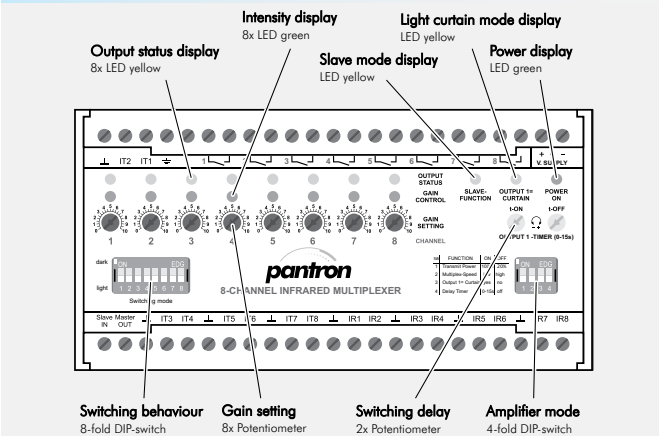

Technical data (at 20°C)	
Operating voltage	see purchase order table
Operating basis	modulated infrared light
Transmit frequency	4.0 kHz
Transmit power	manual
Basic transmit level	low / high
Switching behaviour	light / dark
Switching delay	0 ... 15 s
Multiplex speed	34 ms / 68 ms
Light curtain	yes
Master/Slave operation	yes
Switching output	8x relay, normally open
Operation values (max.)	5 A / 230 V AC (24 V DC)
Reaction time	34 ms (Multiplex speed: 34 ms) 68 ms (Multiplex speed: 68 ms)
Alarm output	—
Test input	—
Analog output	—
COM-Interface	—
Housing material	plastic
Protection class (EN 60529)	IP 20
Connection	screw terminals
Operating temperature	-25 °C ... 50 °C
Dimensions (W x H x D)	149 x 75 x 110 mm see picture 15 on page 56

Amplifier mode (factory setting is marked white)

	Basic transmit level	Multiplex speed	Light curtain	Switching delay
	1	2	3	4
high	ON	68 ms	ON	ON
low	OFF	34 ms	OFF	OFF

For more detailed information see www.pantron.com

Maximum Range (through beam)

	Receiver IRL-...	Receiver IR-...
Transmitter IT-..., ITL-...	10 m	20 m
Transmitter IT-...HP, ITH-...	15 m	30 m
Transmitter ITA-...	20 m	40 m

Connection diagram

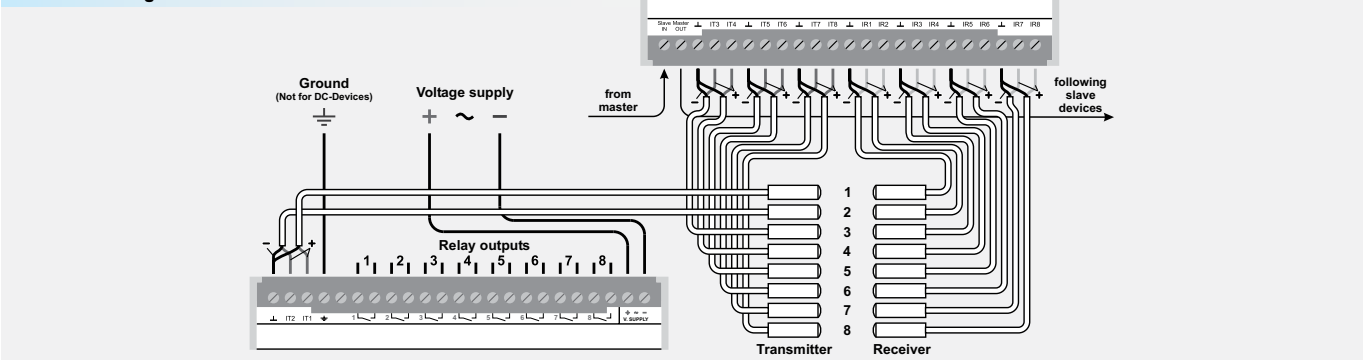



2-channel multiplex amplifier **IMX-A2023** / **IMX-A2024**

- Detection range up to 40 m
- Automatic transmit power adjustment
- Test function
- Basic transmit level 4-fold selectable
- Switching behaviour light / dark selectable
- Switching output (**IMX-A2023** with transistor output and **IMX-A2024** with relay output, normally open)

Technical data (at 20°C)

Operating voltage	see purchase order table
Operating basis	modulated infrared light
Transmit frequency	4.0 kHz
Transmit power	automatic
Basic transmit level	low1 / low2 / high1 / high2
Switching behaviour	light / dark
Switching delay	—
Multiplex speed	4 ms
Light curtain	—
Master/Slave operation	—
Switching output IMX-A2023	2x transistor, NPN / PNP
Operation values (max.)	30 mA / 30 V DC
Reaction time	8 ms
Switching output IMX-A2024	2x relay, normally open
Operation values (max.)	5 A / 230 V AC (24 V DC)
Reaction time	25 ms
Alarm output	—
Test input	—
Analog output	—
COM-Interface	—
Housing material	plastic
Protection class (EN 60529)	IP 40
Connection	11-pole DIN-plug
Operating temperature	-25 °C ... 50 °C
Dimensions (W x H x D)	40 x 76.5 x 78.5 mm see <i>picture 13</i> on page 56

For more detailed information see www.pantron.com

Maximum Range (through beam)

	Receiver IRL-...	Receiver IR-...
Transmitter IT-..., ITL-...	7 m	13 m
Transmitter IT-...HP, ITH-...	9 m	20 m
Transmitter ITA-...	15 m	40 m

Connection diagram

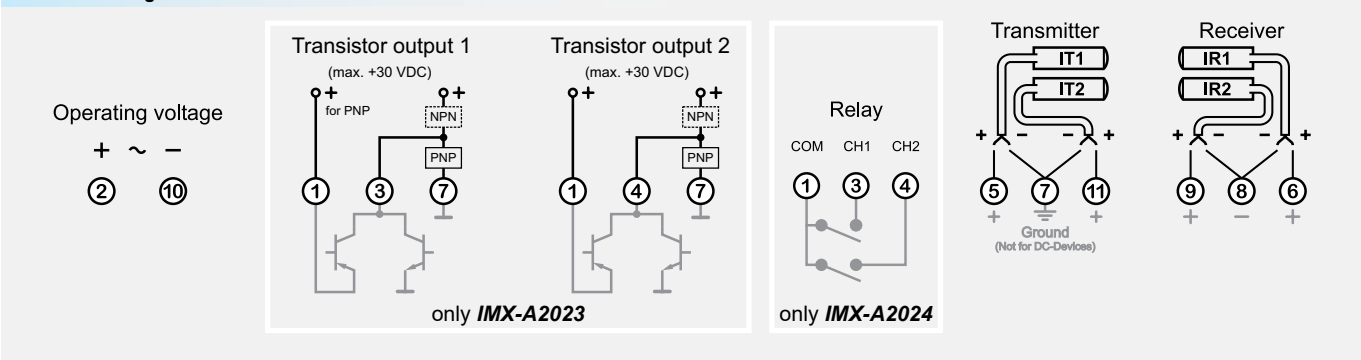

Purchase order table

Operation voltage	Order code	
230 V AC / ± 10% / 4.1 VA	IMX-A2023/230VAC	IMX-A2024/230VAC
115 V AC / ± 10% / 4.1 VA	IMX-A2023/115VAC	IMX-A2024/115VAC
24 V AC / ± 10% / 4.1 VA	IMX-A2023/24VAC	IMX-A2024/24VAC
24 V DC / ± 20% / 2.0 W	IMX-A2023/24VDC	IMX-A2024/24VDC
Accessories	Order code	Page
Protective enclosure	PanBox 1x2	78
11-pole DIN-socket	ISO1	85
Retaining clip	RTC 11	85

Device description

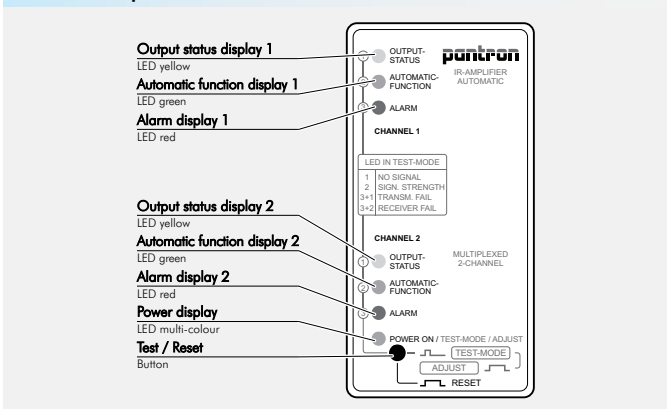

Amplifier mode (factory setting is marked white)

ON 1 2 3 4 5 6	Channel 1		Channel 2					
	Basic transmit level	Switching behaviour	Basic transmit level	Switching behaviour				
	1	2	3	4	5	6		
high2	ON	ON	dark	ON	ON	dark	ON	
high1	ON	OFF		high1	ON	OFF		
low2	OFF	ON	light	low2	OFF	ON	light	OFF
low1	OFF	OFF		low1	OFF	OFF		

2-channel multiplex amplifier **IMX-A2033 / IMX-A2034**

- Detection range up to 40 m
- Automatic transmit power adjustment
- Test function
- Basic transmit level 4-fold selectable
- Switching behaviour light / dark selectable
- Switching delay
- Switching output (**IMX-A2033** with transistor output and **IMX-A2034** with relay output, normally open)



Purchase order table

Operation voltage	Order code	
230 V AC / ± 10% / 4.1 VA	IMX-A2033/230VAC	IMX-A2034/230VAC
115 V AC / ± 10% / 4.1 VA	IMX-A2033/115VAC	IMX-A2034/115VAC
24 V AC / ± 10% / 4.1 VA	IMX-A2033/24VAC	IMX-A2034/24VAC
24 V DC / ± 20% / 2.0 W	IMX-A2033/24VDC	IMX-A2034/24VDC
Accessories	Order code	Page
Protective enclosure	PanBox 1x2	78
11-pole DIN-socket	ISO1	85
Retaining clip	RTC 11	85

Technical data (at 20°C)

Operating voltage	see purchase order table
Operating basis	modulated infrared light
Transmit frequency	4.0 kHz
Transmit power	automatic
Basic transmit level	low1 / low2 / high1 / high2
Switching behaviour	light / dark
Switching delay	0 ... 10 s
Multiplex speed	4 ms
Light curtain	—
Master/Slave operation	—
Switching output IMX-A2033	2x transistor, NPN / PNP
Operation values (max.)	30 mA / 30 V DC
Reaction time	8 ms
Switching output IMX-A2034	2x relay, normally open
Operation values (max.)	5 A / 230 V AC (24 V DC)
Reaction time	25 ms
Alarm output	—
Test input	—
Analog output	—
COM-Interface	—
Housing material	plastic
Protection class (EN 60529)	IP 40
Connection	11-pole DIN-plug
Operating temperature	-25 °C ... 50 °C
Dimensions (W x H x D)	40 x 76.5 x 78.5 mm see picture 13 on page 56

Device description

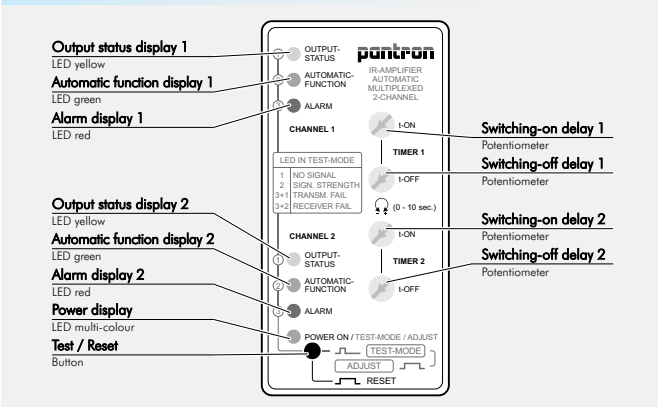

Amplifier mode (factory setting is marked white)

ON 1 2 3 4 5 6	Channel 1		Channel 2			
	Basic transmit level	Switching behaviour	Basic transmit level	Switching behaviour		
	1	2	3	4	5	6
high2	ON	ON	dark	ON	ON	dark
high1	ON	OFF	dark	ON	OFF	ON
low2	OFF	ON	light	OFF	ON	light
low1	OFF	OFF	light	OFF	OFF	OFF

Maximum Range (through beam)

	Receiver IRL-...	Receiver IR-...
Transmitter IT-..., ITL-...	7 m	13 m
Transmitter IT-...HP, ITH-...	9 m	20 m
Transmitter ITA-...	15 m	40 m

Connection diagram

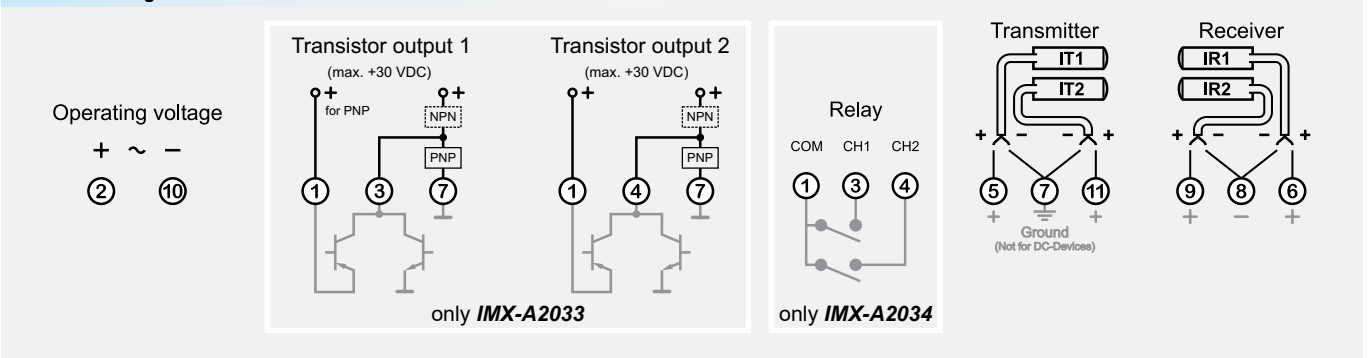



8-channel multiplex amplifier **IMX-A830 / IMX-A832**

- Detection range up to 55 m
- Automatic transmit power adjustment
- Test function
- Basic transmit level 2-fold programmable (**IMX-A830**)
Basic transmit level 4-fold selectable (**IMX-A832**)
- Switching behaviour light / dark programmable resp. selectable
- Switching delay
- Transistor output, NPN / PNP
- Alarm output
- Sensor control
- Master/Slave operation
- Mounting for DIN rail (EN 60715)

Technical data (at 20°C)

Operating voltage	see purchase order table
Operating basis	modulated infrared light
Transmit frequency	4.0 kHz
Transmit power	automatic
Basic transmit level IMX-A830	low / high
Basic transmit level IMX-A832	low1 / low2 / high1 / high2
Switching behaviour	light / dark
Switching delay	0 ... 7 s
Multiplex speed	36 ms
Light curtain	—
Master/Slave operation	yes
Switching output	8x transistor, NPN / PNP
Operation values (max.)	100 mA / 24 V DC
Reaction time	36 ms
Alarm output	PNP
Operation values (max.) ...AC	5 mA / 24 V DC
Operation values (max.) ...DC	100 mA / 24 V DC
Test input	—
Analog output	—
COM-Interface	—
Housing material	plastic
Protection class (EN 60529)	IP 20
Connection	screw terminals
Operating temperature	-25 °C ... 50 °C
Dimensions (W x H x D)	149 x 75 x 110 mm see picture 15 on page 56

For more detailed information see www.pantron.com

Maximum Range (through beam)

	Receiver IRL-...	Receiver IR-...
Transmitter IT-..., ITL-...	8 m	15 m
Transmitter IT-...HP, ITH-...	10 m	20 m
Transmitter ITA-...	20 m	55 m

Connection diagram

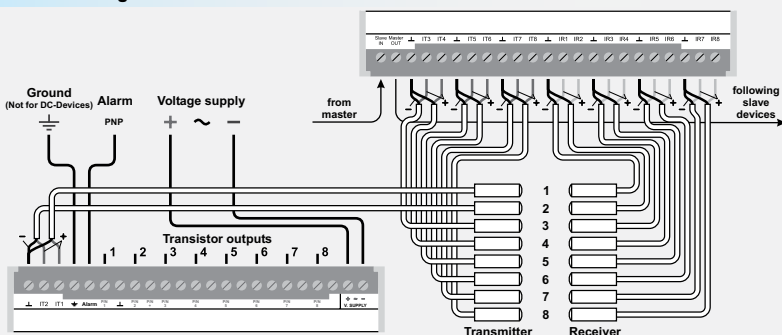

Purchase order table

Operation voltage	Order code	
230 V AC / ± 10% / 10.4 VA	IMX-A830/230VAC	IMX-A832/230VAC
115 V AC / ± 10% / 10.4 VA	IMX-A830/115VAC	IMX-A832/115VAC
24 V AC / ± 10% / 10.4 VA	IMX-A830/24VAC	IMX-A832/24VAC
24 V DC / ± 20% / 6.3 W	IMX-A830/24VDC	IMX-A832/24VDC

Accessories	Order code	Page
Protective enclosure	PanBox 1x8	79

Device description

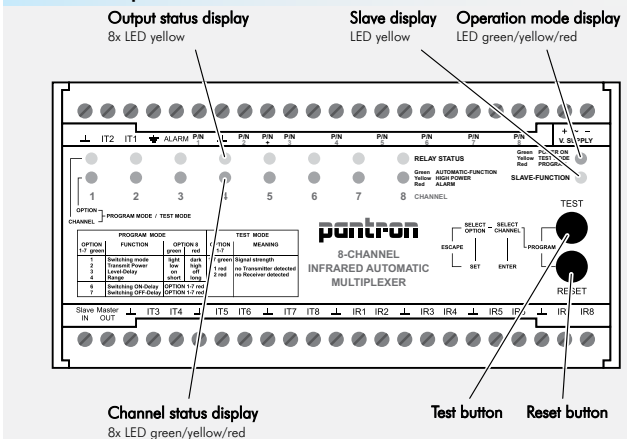

Amplifier mode (only IMX-A832, factory setting is marked white)

The functions are selectable by three DIP-switches on the left side of the housing. All functions can be selected independently for each channel. The number on the DIP-switch is equal with the number of the transmit channel.

DIP-switch 1	DIP-switch 2	DIP-switch 3
ON	ON	ON
1	2	3
2	3	4
3	4	5
4	5	6
5	6	7
6	7	8
7	8	1
8	1	2
1	2	3
2	3	4
3	4	5
4	5	6
5	6	7
6	7	8
7	8	1
8	1	2

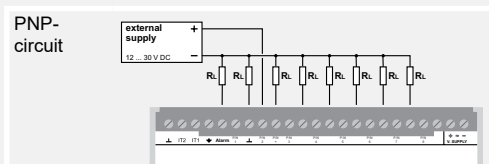
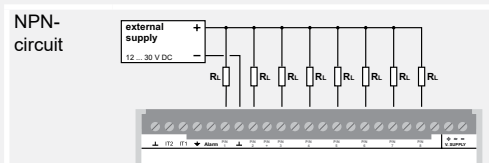

8-channel multiplex amplifier IMX-A840 / IMX-A842

- Detection range up to 55 m
- Automatic transmit power adjustment
- Test function
- Basic transmit level 2-fold programmable (*IMX-A840*)
Basic transmit level 4-fold selectable (*IMX-A842*)
- Switching behaviour light / dark programmable resp. selectable
- Switching delay
- Relay output, normally open
- Alarm output
- Sensor control
- Master/Slave operation
- Mounting for DIN rail (EN 60715)



Purchase order table		
Operation voltage	Order code	
230 V AC / ± 10% / 10.4 VA	IMX-A840/230VAC	IMX-A842/230VAC
115 V AC / ± 10% / 10.4 VA	IMX-A840/115VAC	IMX-A842/115VAC
24 V AC / ± 10% / 10.4 VA	IMX-A840/24VAC	IMX-A842/24VAC
24 V DC / ± 20% / 6.3 W	IMX-A840/24VDC	IMX-A842/24VDC

Accessories	Order code	Page
Protective enclosure	PanBox 1x8	79

Technical data (at 20°C)	
Operating voltage	see purchase order table
Operating basis	modulated infrared light
Transmit frequency	4.0 kHz
Transmit power	automatic
Basic transmit level <i>IMX-A840</i>	low / high
Basic transmit level <i>IMX-A842</i>	low1 / low2 / high1 / high2
Switching behaviour	light / dark
Switching delay	0 ... 7 s
Multiplex speed	36 ms
Light curtain	—
Master/Slave operation	yes
Switching output	8x relay, normally open
Operation values (max.)	5 A / 230 V AC (24 V DC)
Reaction time	36 ms
Alarm output	PNP
Operation values (max.) ...AC	5 mA / 24 V DC
Operation values (max.) ...DC	100 mA / 24 V DC
Test input	—
Analog output	—
COM-Interface	—
Housing material	plastic
Protection class (EN 60529)	IP 20
Connection	screw terminals
Operating temperature	-25 °C ... 50 °C
Dimensions (W x H x D)	149 x 75 x 110 mm see picture 15 on page 56

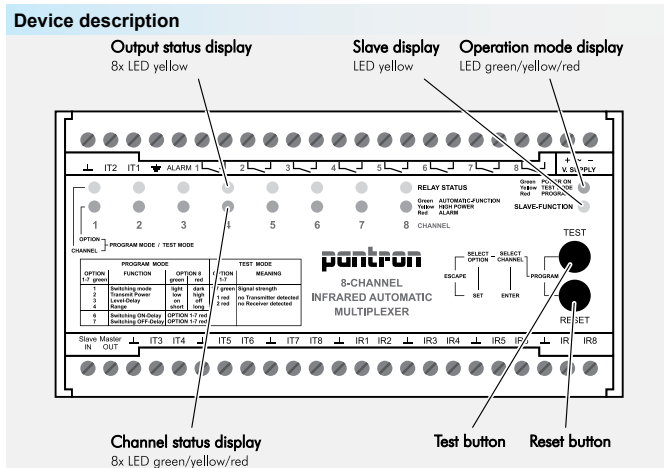

Amplifier mode (only IMX-A842, factory setting is marked white)

The functions are selectable by three DIP-switches on the left side of the housing. All functions can be selected independently for each channel. The number on the DIP-switch is equal with the number of the transmit channel.

DIP-switch 1	DIP-switch 2	DIP-switch 1	DIP-switch 2	DIP-switch 3
ON	ON	ON	ON	ON
1	1	1	1	1
2	2	2	2	2
3	3	3	3	3
4	4	4	4	4
5	5	5	5	5
6	6	6	6	6
7	7	7	7	7
8	8	8	8	8

Switching function	Basic transmit level	
	Basic power	level
dark	ON	high
light	OFF	low

For more detailed information see www.pantron.com

Maximum Range (through beam)	Receiver IRL-...	Receiver IR-...
	Transmitter IT-..., ITL-...	8 m
Transmitter IT-...HP, ITH-...	10 m	20 m
Transmitter ITA-...	20 m	55 m

Connection diagram

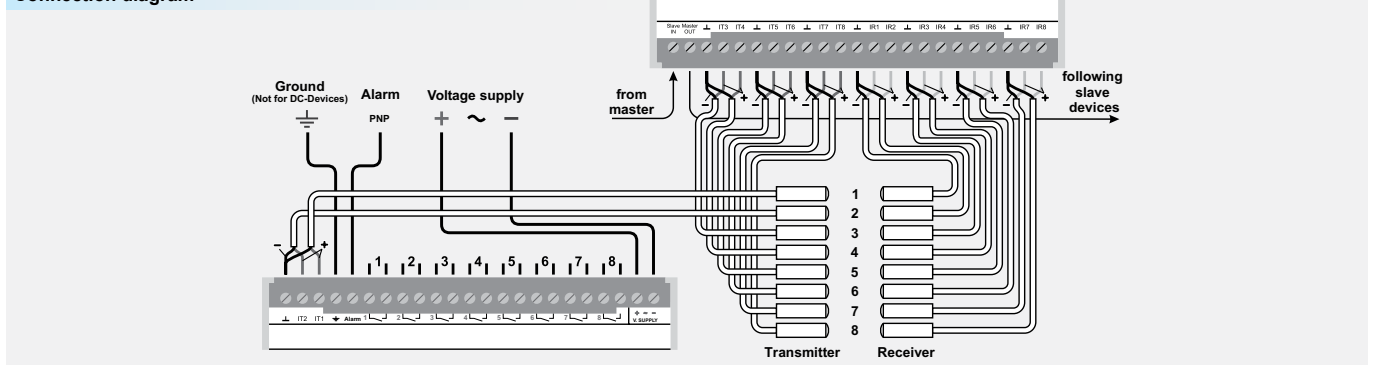

Notes

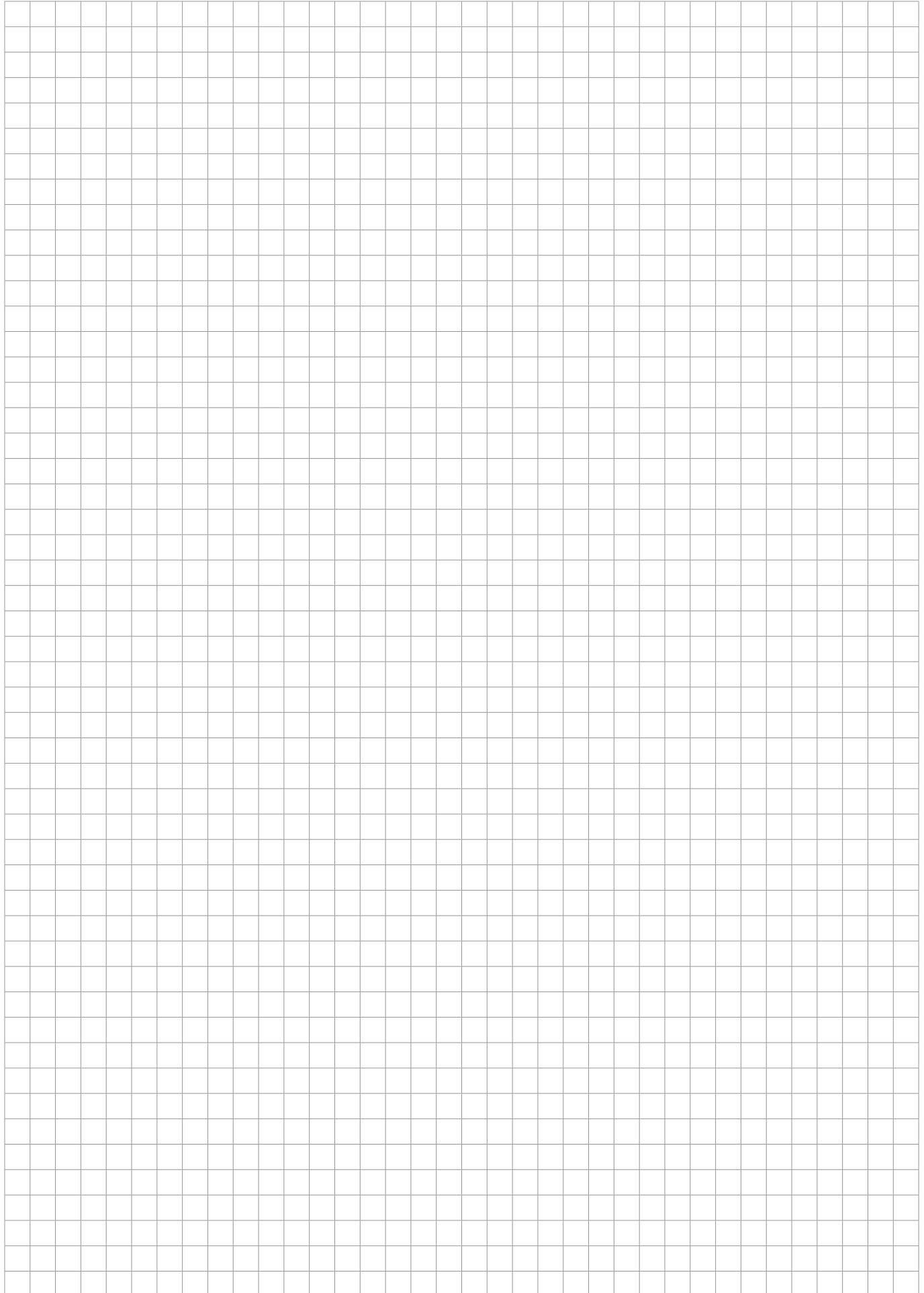

Special amplifier



Overview

General	S. 42
Light detector ILD-1000	S. 43
1-channel amplifier ISM-1230	S. 44
1-channel amplifier ISG-A103	S. 45
1-channel amplifier ISM-1800	S. 46
2-channel multiplex amplifier ISM-2800	S. 47
4-channel multiplex amplifier ISM-4800	S. 48
8-channel multiplex amplifier ISM-8800	S. 49
1-channel automatic amplifier ISG-A101	S. 50
1-channel automatic amplifier ISG-A104	S. 51
2-channel multiplex amplifier ICL-2000	S. 52
6-channel multiplex amplifier ICL-6000	S. 53
8-channel multiplex amplifier ICL-8000	S. 54

Development of customer-specific devices by Pantron

Based on our high performance light barriers, a variety of devices, also customer specific devices, may be developed for different applications. The following illustrations represent several ways these devices may be used in automated applications. Pantron has the capability to develop customer-specific devices in single-piece and low-volume production.

Applications

Light detector

- for the detection of intensive, non-uniform light, e. g. arc welding or laser works of metallic pieces

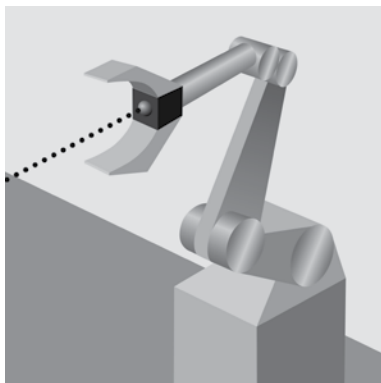

Dust and turbidity measurement

- for optical dust and turbidity measurement, e. g. for exhaust ventilation

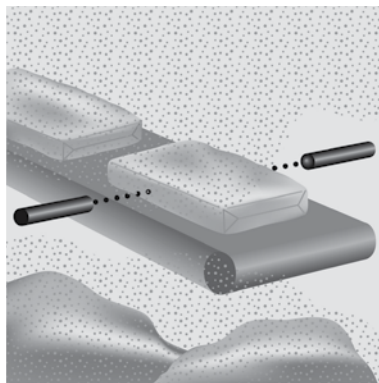

Vehicle wash

- High humidity, with a high condensation of water and drizzle on the optical system, as in vehicle wash systems

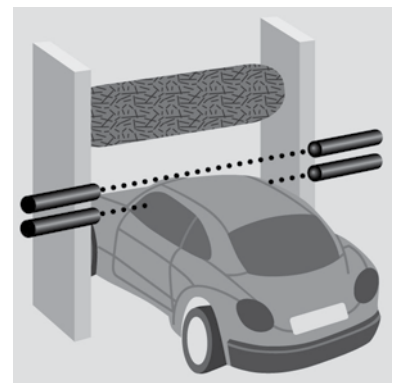

Product overview - Special amplifiers

Series	light barriers (channels)	maximum range [m] (through beam)	transmit power adjustment (automatic)	transmit power adjustment (manual)	switching behaviour (light)	switching behaviour (dark)	switching delay	switching output					basic transmit level	sensor control	transmit frequency	master/slave operation	teach function	analog output	alarm output	test input	connection				page	
								relay (normally open)	relay (change over)	semiconductor relay	transistor (PNP)	transistor (NPN)									DIN-plug	plug (screw terminals)	plug (spring clamp terminals)	screw terminals		
ILD-1000	1						▪			▪		2					▪	▪				▪				43
ISM	ISM-1230	1	55	▪						▪		2	▪	2			▪	▪	▪			▪				44
	ISM-1800	1	55	▪		▪				▪		4	▪	4				▪	▪	▪		▪				46
	ISM-2800	2	55	▪		▪				▪		4	▪	1				▪	▪	▪		▪				47
	ISM-4800	4	60	▪	▪	▪	▪	▪		▪		6	▪	1				▪	▪	▪		▪				48
	ISM-8800	8	60	▪	▪	▪	▪	▪		▪		6	▪	1				▪	▪	▪		▪				49
ISG	ISG-A101	1	50	▪		▪				▪		4	▪	4					▪			▪				50
	ISG-A103	1	50	▪		▪			▪			1		1								▪				45
	ISG-A104	1	50	▪		▪	▪			▪		4	▪	4					▪			▪				51
ICL	ICL-2000	2	35	▪	▪	▪	▪				▪	4	▪	1	▪			▪	▪	▪			▪			52
	ICL-6000	6	35	▪	▪	▪	▪				▪	4	▪	1	▪			▪	▪	▪			▪			53
	ICL-8000	8	35	▪	▪	▪	▪				▪	4	▪	1	▪			▪	▪	▪			▪			54

Light detector ILD-1000

- Detector for non-uniform (modulated) infrared light
- Floating distance switching output - short circuit proof
- Analog output 0 ... 10 V DC
- Sensor control
- Alarm output for sensor control
- Mounting for DIN rail (EN 60715)



Device description

The light sensor ILD-1000 is used for the detection of intensive, non-uniform light that typically arises by reason of

- Arc welding
- Laser works of metallic pieces

This device detects the existence as well as the non-existence of an arc and is made for error detection for automatic manufacturing processes. The system consists of the evaluation device ILD-1000 and the sensor IR-M12VA (see page 58).

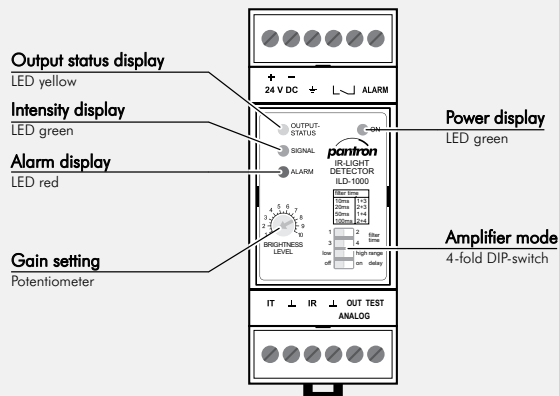

Technical data (at 20°C)

Operating voltage	24 V DC / ±20%
Power consumption	2.4 W
Filter time	10 ms / 20 ms / 50 ms / 100 ms
Measurement range	low / high
Impulse extension	0 ms / 100 ms
Switching output	semiconductor relay, normally open
Operation values (max.)	100 mA / 60 V AC (DC) / R _{ON} = 23 Ohm
Alarm output	PNP
Operation values (max.)	100 mA / 24 V DC
Test input	—
Analog output	0 ... 10 V DC
Mounting	DIN rail (EN 60715)
Housing material	NORYL, grey
Protection class (EN 60529)	IP 20
Connection	see purchase order table
Wire size	0.14 ... 2.5 mm ²
Operating temperature	-25 °C ... 50 °C
Dimensions (W x H x D)	35.5 x 90 x 58.5 mm
ILD-1000	see picture 3 on page 55
ILD-1000S	see picture 4 on page 55

For more detailed information see www.pantron.com

Amplifier mode (factory setting is marked white)

		10 ms	20 ms	50 ms	100 ms
1	Filter time	<input type="checkbox"/>	<input type="checkbox"/>	<input type="checkbox"/>	<input type="checkbox"/>
		<input type="checkbox"/>	<input type="checkbox"/>	<input type="checkbox"/>	<input type="checkbox"/>
2	Measurement range	high		low	
		<input type="checkbox"/>	<input type="checkbox"/>	<input type="checkbox"/>	<input type="checkbox"/>
3	Delay	off		on	
		<input type="checkbox"/>	<input type="checkbox"/>	<input type="checkbox"/>	<input type="checkbox"/>

Purchase order table

Connection	Order code	
Plug (screw terminals)	ILD-1000/24VDC	
Screw terminals	ILD-1000S/24VDC	
Accessories	Order code	Page
Protective enclosure	PanBox 1x1	78
Power supply PSU-1000	PSU-1000S/95...265VAC	80

Connection diagram

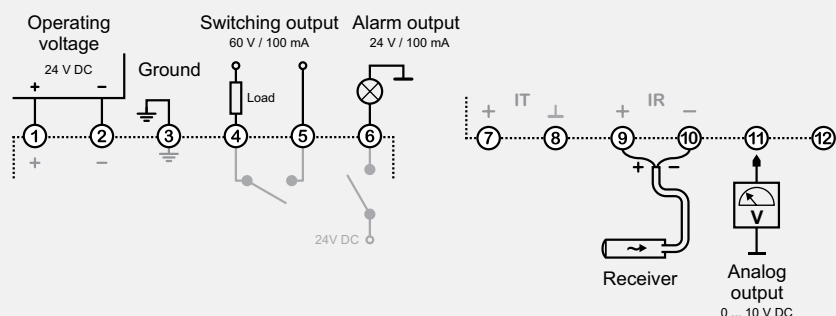

Special amplifier



1-channel amplifier ISM-1230

- Special amplifier for optical dust and turbidity measurement
- Detection range up to 55 m
- Automatic operation
- Basic transmit level 2-fold selectable
- Transmit frequency 2-fold selectable
- Floating distance switching output - short circuit proof
- Analog output
- Alarm output for power limit
- Input for "Teach" function
- Sensor control
- Mounting for DIN rail (EN 60715)

Technical data (at 20°C)

Operating voltage	24 V DC / ±20% / 2.4 W
Operating basis	modulated infrared light
Transmit frequency	3.7 kHz / 4.3 kHz
Transmit power	automatic
Basic transmit level	low / high
Switching output	semiconductor relay, normally open
Operation values (max.)	100 mA / 60 V AC (DC)
Reaction time	24 ms
Alarm output	PNP
Operation values (max.)	100 mA / 24 V DC
Test input	0 ... 30 V DC
Analog output	0 ... 10 V DC
Housing material	NORYL, grey
Protection class (EN 60529)	IP 20
Connection	Plug with screw terminals
Wire size	0.14 ... 2.5 mm ²
Operating temperature	-25 °C ... 50 °C
Dimensions (W x H x D)	35.5 x 90 x 58.5 mm see picture 3 on page 55

For more detailed information see www.pantron.com

Maximum Range (through beam)

	Receiver IRL-...	Receiver IR-...
Transmitter IT-..., ITL-...	7 m	15 m
Transmitter IT-...HP, ITH-...	10 m	25 m
Transmitter ITA-...	20 m	55 m

Purchase order table

Connection	Order code
Plug (screw terminals)	ISM-1230/24VDC

Accessories	Order code	Page
Protective enclosure	PanBox 1x1	78
Power supply PSU-1000	PSU-1000S/95...265VAC	80

Device description

The ISM-1230 is a one-channel amplifier used for optical dust and turbidity measurement. For operation, one infrared transmitter and receiver has to be connected (see sensors).

The light beam goes through the observed medium. This system works with modulated infrared light. The amplifier adjusts the transmit power automatically so the receiver always gets the same signal strength. Proportional to the transmit power, the analog output delivers a voltage 0-10 V DC. The voltage depends on

- the distance between transmitter and receiver
- the justification of the sensors
- the pollution of the sensors
- the actual turbidity of the medium between the sensors

On the precondition, sensors are mounted in a fixed position and the turbidity changes timewise relatively fast, the signal at the output is only dependent on the actual turbidity. A pollution of the sensors changes slowly and the amplifier is able to compensate this with an offset.

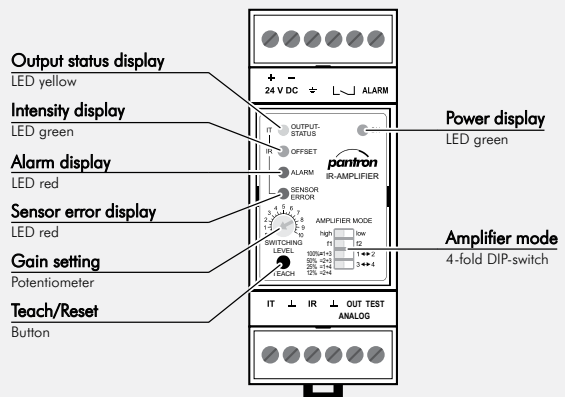

Amplifier mode (factory setting is marked white)

		high	low
1	Basic transmit level	<input checked="" type="checkbox"/>	<input type="checkbox"/>
2	Transmit frequency	3.7 kHz	4.3 kHz
3	Measurement range	<input checked="" type="checkbox"/> 100%	<input checked="" type="checkbox"/> 50%
4		<input type="checkbox"/> 25%	<input type="checkbox"/> 12%

Connection diagram

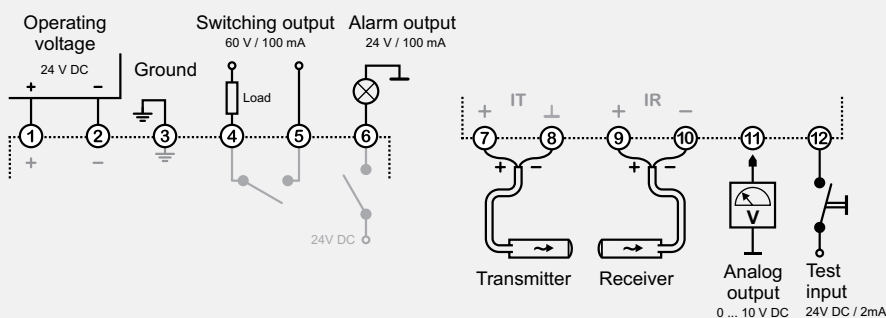

1-channel amplifier ISG-A103

- Detection range up to 50 m
- Automatic transmit power adjustment
- Relay output, normally open



Device description

The amplifier ISG-A103 is intended for the operation of sensors in gate systems with a rubber safety edge. It differs from other amplifiers of the series ISG-A... due to a very high sensitivity and an especially short turn-on time.

The connections of the relay are designed so that older light barrier amplifiers from Pantron with redundant output connections can be replaced without changes of the wiring.

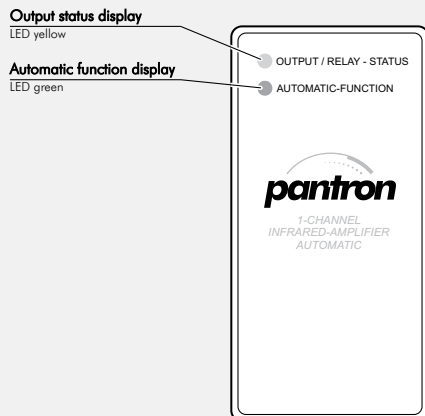

Technical data (at 20°C)

Operating voltage	see purchase order table
Operating basis	modulated infrared light
Transmit frequency	3.9 kHz
Transmit power	automatic
Basic transmit level	low
Switching behaviour	light
Switching delay	—
Switching output	relay, normally open
Operation values (max.)	5 A / 230 V AC (24 V DC)
Reaction time	25 ms
Alarm output	—
Test input	—
Housing material	plastic
Protection class (EN 60529)	IP 40
Connection	11-pole DIN-plug
Operating temperature	-25 °C ... 50 °C
Dimensions (W x H x D)	40 x 76.5 x 78.5 mm see picture 12 on page 56

Maximum Range (through beam)

	Receiver IRL-...	Receiver IR-...
Transmitter IT-..., ITL-...	7 m	15 m
Transmitter IT-...HP, ITH-...	10 m	25 m
Transmitter ITA-...	20 m	50 m

Purchase order table

Operation voltage	Order code	
230 V AC / ± 10% / 4.1 VA	ISG-A103/230VAC	
115 V AC / ± 10% / 4.1 VA	ISG-A103/115VAC	
24 V AC / ± 10% / 4.1 VA	ISG-A103/24VAC	
24 V DC / ± 20% / 1.9 W	ISG-A103/24VDC	
Accessories	Order code	Page
Protective enclosure	PanBox 1x1	78
11-pole DIN-socket	ISO1	85
Retaining clip	RTC 11	85

Connection diagram

Operating voltage

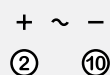

Relay

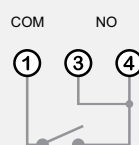

Transmitter

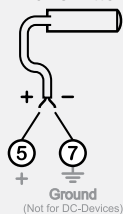

Receiver

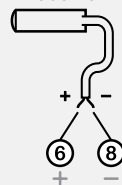



1-channel amplifier ISM-1800

- Detection range up to 55 m
- Automatic operation
- Basic transmit level 4-fold selectable
- Transmit frequency 4-fold selectable
- Floating distance switching output - short circuit proof
- Alarm output for power limit
- Test input for system check
- Sensor control
- Mounting for DIN rail (EN 60715)

Technical data (at 20°C)

Operating voltage	24 V DC / ±20% / 2.4 W
Operating basis	modulated infrared light
Transmit frequency	3.5 kHz / 3.9 kHz / 4.2 kHz / 4.5 kHz
Transmit power	automatic
Basic transmit level	low1 / low2 / high1 / high2
Switching behaviour	light
Switching delay	—
Multiplex speed	—
Master/Slave operation	—
Switching output	semiconductor relay, normally open
Operation values (max.)	100 mA / 60 V AC (DC)
Reaction time	24 ms
Alarm output / Error output	PNP / —
Operation values (max.)	100 mA / 24 V DC
Test input	0 ... 30 V DC
Analog output	—
COM-Interface	—
Housing material	NORYL, grey
Protection class (EN 60529)	IP 20
Connection	Plug with screw terminals
Wire size	0.14 ... 2.5 mm ²
Operating temperature	-25 °C ... 50 °C
Dimensions (W x H x D)	35.5 x 90 x 58.5 mm
ISM-1800	see <i>picture 3</i> on page 55

For more detailed information see www.pantron.com

Maximum Range (through beam)

	Receiver IRL-...	Receiver IR-...
Transmitter IT-..., ITL-...	7 m	15 m
Transmitter IT-...HP, ITH-...	10 m	25 m
Transmitter ITA-...	20 m	55 m

Connection diagram

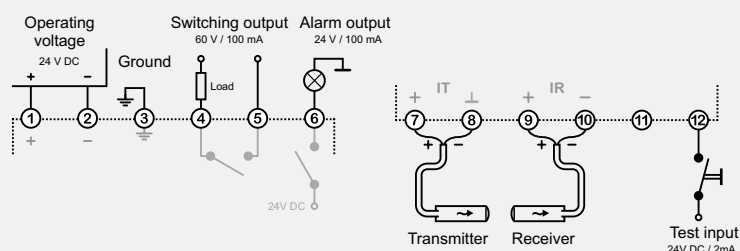

Purchase order table

Connection	Order code
Plug (screw terminals)	ISM-1800/24VDC

Accessories	Order code	Page
Protective enclosure	PanBox 1x1	78
Power supply PSU-1000	PSU-1000S/95...265VAC	80

Device description

The light barrier amplifier ISM-1800 is a one-channel amplifier with automatic operation, rated in four basic transmit levels. Because of the special parameter settings and other properties, this amplifier is especially suited for vehicle wash applications.

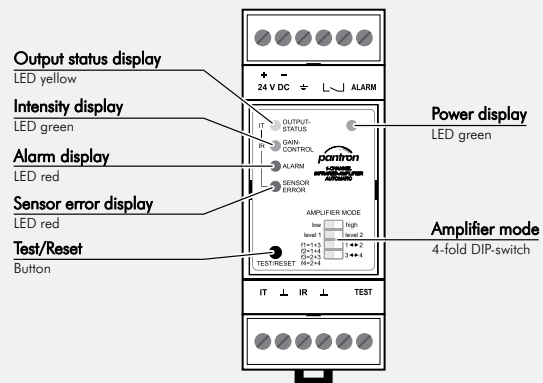

Amplifier mode (factory setting is marked white)

	low1	low2	high1	high2
1 Basic transmit level	<input type="checkbox"/>	<input type="checkbox"/>	<input type="checkbox"/>	<input type="checkbox"/>
	<input type="checkbox"/>	<input type="checkbox"/>	<input type="checkbox"/>	<input type="checkbox"/>
3 Transmit frequency	<input type="checkbox"/>	<input type="checkbox"/>	<input type="checkbox"/>	<input type="checkbox"/>
	<input type="checkbox"/>	<input type="checkbox"/>	<input type="checkbox"/>	<input type="checkbox"/>
	<input type="checkbox"/>	<input type="checkbox"/>	<input type="checkbox"/>	<input type="checkbox"/>
	<input type="checkbox"/>	<input type="checkbox"/>	<input type="checkbox"/>	<input type="checkbox"/>

2-channel multiplex amplifier ISM-2800

- Detection range up to 55 m
- Automatic operation
- Basic transmit level 4-fold selectable
- Floating distance switching output - short circuit proof
- Alarm output for power limit
- Test input for system check
- Sensor control
- Mounting for DIN rail (EN 60715)



Purchase order table

Connection	Order code	
Plug (screw terminals)	ISM-2800/24VDC	
Accessories	Order code	Page
Protective enclosure	PanBox 1x2	78
Power supply PSU-1000	PSU-1000S/95...265VAC	80

Device description

The light barrier amplifier ISM-2800 is a two-channel amplifier with automatic operation, rated in four basic transmit levels. Because of the special parameter settings and other properties, this amplifier is especially suited for vehicle wash applications.

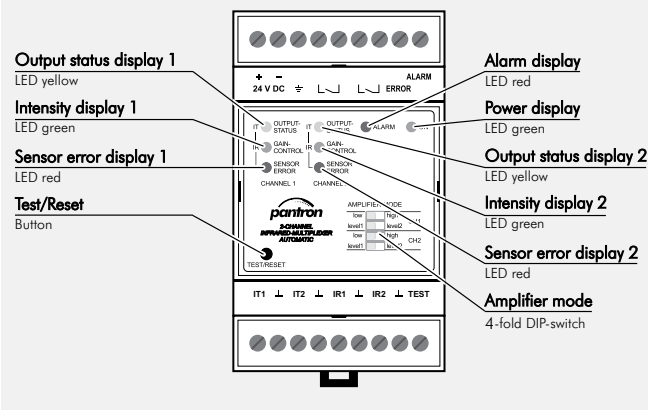

Technical data (at 20°C)

Operating voltage	24 V DC / ±20% / 3.6 W
Operating basis	modulated infrared light
Transmit frequency	3.9 kHz
Transmit power	automatic
Basic transmit level	low1 / low2 / high1 / high2
Switching behaviour	light
Switching delay	—
Multiplex speed	8 ms
Master/Slave operation	—
Switching output	2x semiconductor relay, normally open
Operation values (max.)	100 mA / 60 V AC (DC)
Reaction time	24 ms
Alarm output / Error output	PNP / PNP
Operation values (max.)	100 mA / 24 V DC
Test input	0 ... 30 V DC
Analog output	—
COM-Interface	—
Housing material	NORYL, grey
Protection class (EN 60529)	IP 20
Connection	see purchase order table
Wire size	0.14 ... 2.5 mm ²
Operating temperature	-25 °C ... 50 °C
Dimensions (W x H x D)	35.5 x 90 x 58.5 mm
ISM-2800	see picture 5 on page 55

Amplifier mode (factory setting is marked white)

		low1	low2	high1	high2
1	Basic transmit level channel 1	<input type="checkbox"/>	<input type="checkbox"/>	<input type="checkbox"/>	<input type="checkbox"/>
		<input type="checkbox"/>	<input type="checkbox"/>	<input type="checkbox"/>	<input type="checkbox"/>
3	Basic transmit level channel 2	<input type="checkbox"/>	<input type="checkbox"/>	<input type="checkbox"/>	<input type="checkbox"/>
		<input type="checkbox"/>	<input type="checkbox"/>	<input type="checkbox"/>	<input type="checkbox"/>

For more detailed information see www.pantron.com

Maximum Range (through beam)

	Receiver IRL-...	Receiver IR-...
Transmitter IT-..., ITL-...	10 m	15 m
Transmitter IT-...HP, ITH-...	12 m	25 m
Transmitter ITA-...	25 m	60 m

Connection diagram

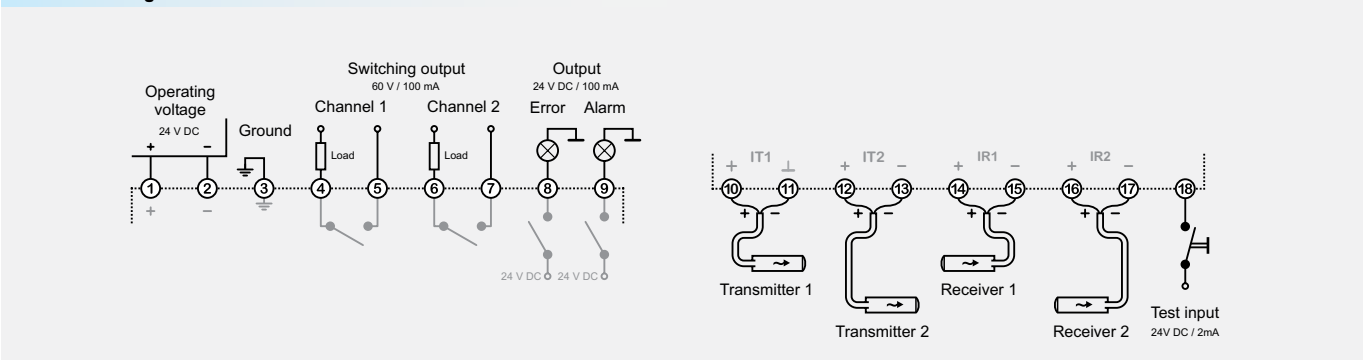



4-channel multiplex amplifier ISM-4800

- Detection range up to 60 m
- Menu-driven operation with display or PC software
- Manual / automatic operation selectable
- Switching behaviour light / dark selectable
- Switching delay
- Floating distance switching outputs - short circuit proof
- Alarm output for power limit
- Analog output
- Test input for system check
- Sensor control with error output
- Master/Slave operation
- Mounting for DIN rail (EN 60715)

Technical data (at 20 °C)

Operating voltage	24 V DC / ±20% / 6.5 W
Operating basis	modulated infrared light
Transmit frequency	4.0 kHz
Transmit power	manual / automatic
Basic transmit level - manual	low / high
Basic transmit level - automatic	low1 / low2 / high1 / high2
Switching behaviour	light / dark
Switching delay	0 ... 60 s
Multiplex speed	18 ms
Master/Slave operation	yes
Switching output	4x Semiconductor relay, normally open
Operation values (max.)	100 mA / 60 V AC (DC)
Reaction time	20 ms
Alarm output / Error output	PNP / PNP
Operation values (max.)	100 mA / 24 V DC
Test input	max. 30 V DC / 2 mA
Analog output	0 ... 10 V DC or 10 ... 0 V DC
COM-Interface	RS232
Housing material	NORYL, grey
Protection class (EN 60529)	IP 20
Connection	plug with screw terminals
Wire size	0.14 ... 2.5 mm ²
Operating temperature	0 °C ... 50 °C
Dimensions (W x H x D)	106 x 90 x 58.5 mm see picture 7 on page 55

For more detailed information see www.pantron.com

Maximum Range (through beam)

	Receiver IRL...	Receiver IR...
Transmitter IT-..., ITL-...	10 m	15 m
Transmitter IT-...HP, ITH-...	12 m	25 m
Transmitter ITA-...	25 m	60 m

Connection diagram

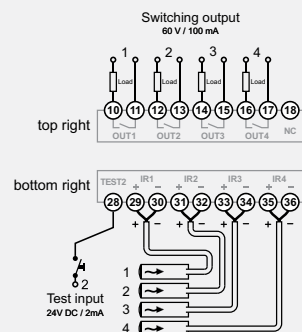
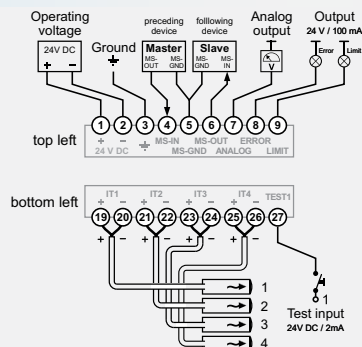

Purchase order table

Connection	Order code	
Plug (screw terminals)	ISM-4800/24VDC	
Accessories	Order code	Page
Protective enclosure	PanBox 1x4	79
Power supply PSU-1000	PSU-1000S/95...265VAC	80
Communication cable	CAB-COM-2	84
PC software	WinISM	85

Device description

The light barrier amplifier ISM-4800 is a four-channel amplifier with automatic operation, rated in four basic transmit levels. Because of the special parameter settings and other properties, this amplifier is especially suited for vehicle wash applications.

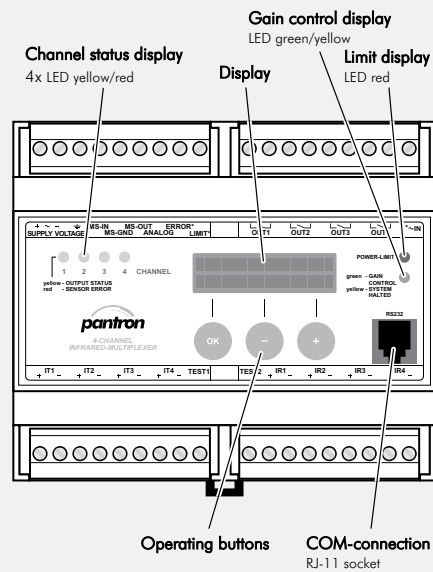

8-channel multiplex amplifier ISM-8800

- Detection range up to 60 m
- Menu-driven operation with display or PC software
- Manual / automatic operation selectable
- Switching behaviour light / dark selectable
- Switching delay
- Floating distance switching outputs - short circuit proof
- Alarm output for power limit
- Analog output
- Test input for system check
- Sensor control with error output
- Master/Slave operation
- Mounting for DIN rail (EN 60715)



Purchase order table

Connection	Order code	
Plug (screw terminals)	ISM-8800/24VDC	
Accessories	Order code	Page
Protective enclosure	PanBox 1x8	79
Power supply PSU-1000	PSU-1000S/95...265VAC	80
Communication cable	CAB-COM-2	84
PC software	WinISM	85

Device description

The light barrier amplifier ISM-8800 is an eight-channel amplifier with automatic operation, rated in four basic transmit levels. Because of the special parameter settings and other properties, this amplifier is especially suited for vehicle wash applications.

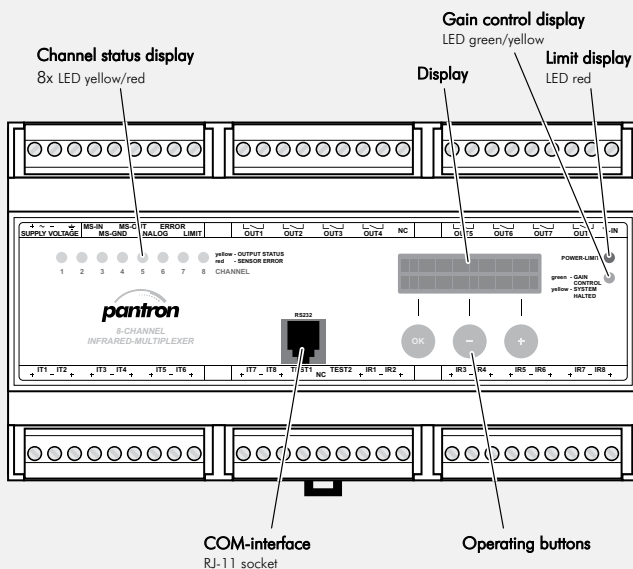

Technical data (at 20 °C)

Operating voltage	24 V DC / $\pm 20\%$ / 8.5 W
Operating basis	modulated infrared light
Transmit frequency	4.0 kHz
Transmit power	manual / automatic
Basic transmit level - manual	low / high
Basic transmit level - automatic	low1 / low2 / high1 / high2
Switching behaviour	light / dark
Switching delay	0 ... 60 s
Multiplex speed	34 ms
Master/Slave operation	yes
Switching output	8x Semiconductor relay, normally open
Operation values (max.)	100 mA / 60 V AC (DC)
Reaction time	36 ms
Alarm output / Error output	PNP / PNP
Operation values (max.)	100 mA / 24 V DC
Test input	max. 30 V DC / 2 mA
Analog output	0 ... 10 V DC or 10 ... 0 V DC
COM-Interface	RS232
Housing material	NORYL, grey
Protection class (EN 60529)	IP 20
Connection	plug with screw terminals
Wire size	0.14 ... 2.5 mm ²
Operating temperature	0 °C ... 50 °C
Dimensions (W x H x D)	158.5 x 90 x 58.5 mm see picture 8 on page 55

For more detailed information see www.pantron.com

Maximum Range (through beam)

	Receiver IRL-...	Receiver IR-...
Transmitter IT-..., ITL-...	10 m	15 m
Transmitter IT-...HP, ITH-...	12 m	25 m
Transmitter ITA-...	25 m	60 m

Connection diagram

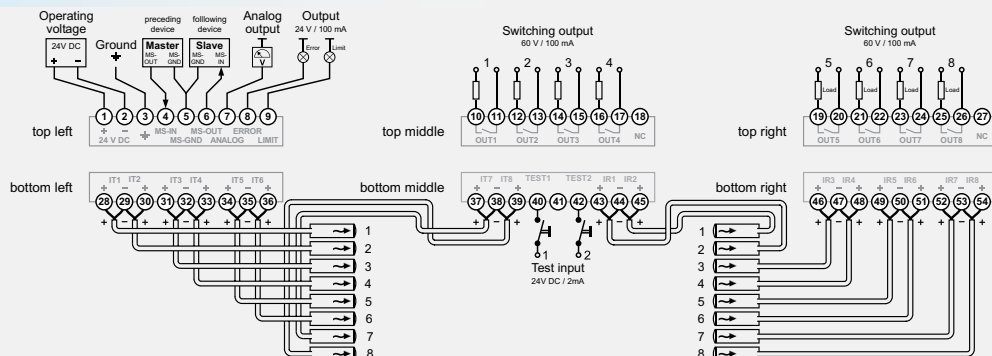



1-channel automatic amplifier ISG-A101

- Detection range up to 50 m
- Automatic transmit power adjustment
- Test function
- Basic transmit level 4-fold selectable
- Transmit frequency 4-fold selectable
- Relay output, change over
- Alarm output

Technical data (at 20°C)

Operating voltage	see purchase order table
Operating basis	modulated infrared light
Transmit frequency	3.7 kHz / 3.85 kHz / 3.97 kHz / 4.1 kHz
Transmit power	automatic
Basic transmit level	low1 / low2 / high1 / high2
Switching behaviour	light
Switching delay	—
Multiplex speed	—
Master/Slave operation	—
Teach function	—
Switching output	relay, change over
Operation values (max.)	5 A / 230 V AC (24 V DC)
Reaction time	25 ms / 52 ms (Basic transmit level: low / high)
Alarm output	PNP
Operation values (max.) ...AC	5 mA / 24 V DC
Operation values (max.) ...DC	100 mA / 24 V DC
Test input	—
Analog output	—
COM-Interface	—
Housing material	plastic
Protection class (EN 60529)	IP 40
Connection	11-pole DIN-plug
Operating temperature	-25 °C ... 50 °C
Dimensions (W x H x D)	40 x 76.5 x 78.5 mm see picture 12 on page 56

For more detailed information see www.pantron.com

Maximum Range (through beam)

	Receiver IRL-...	Receiver IR-...
Transmitter IT-..., ITL-...	7 m	15 m
Transmitter IT-...HP, ITH-...	10 m	25 m
Transmitter ITA-...	20 m	50 m

Connection diagram

Operating voltage

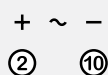

Relay

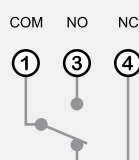

Transmitter

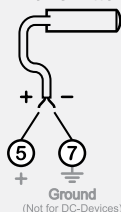

Receiver

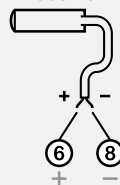

Alarm output
(max. +30 VDC)

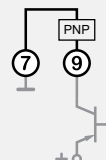

Purchase order table

Operation voltage	Order code
230 V AC / ± 10% / 4.1 VA	ISG-A101/230VAC
115 V AC / ± 10% / 4.1 VA	ISG-A101/115VAC
24 V AC / ± 10% / 4.1 VA	ISG-A101/24VAC
24 V DC / ± 20% / 1.9 W	ISG-A101/24VDC

Accessories	Order code	Page
Protective enclosure	PanBox 1x1	78
11-pole DIN-socket	ISO1	85
Retaining clip	RTC 11	85

Device description

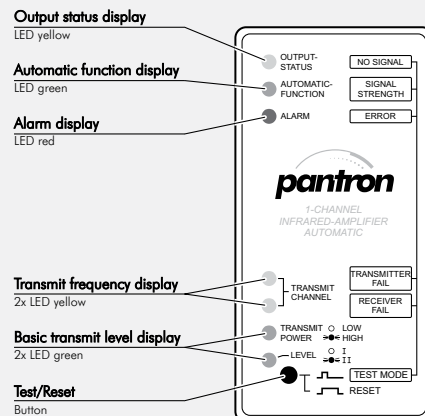

Amplifier mode (factory setting is marked white)



	Basic transmit level		Transmit frequency			
	1	2	3	4	5	6
high2	ON	ON	4.10 kHz	ON	ON	
high1	ON	OFF	3.97 kHz	ON	OFF	
low2	OFF	ON	3.85 kHz	OFF	ON	
low1	OFF	OFF	3.70 kHz	OFF	OFF	

1-channel automatic amplifier ISG-A104

- Detection range up to 50 m
- Automatic transmit power adjustment
- Test function
- Basic transmit level 4-fold selectable
- Switching behaviour light / dark selectable
- Transmit frequency 4-fold selectable
- Relay output, change over
- Alarm output



Purchase order table

Operation voltage	Order code	
230 V AC / ± 10% / 4.1 VA	ISG-A104/230VAC	
115 V AC / ± 10% / 4.1 VA	ISG-A104/115VAC	
24 V AC / ± 10% / 4.1 VA	ISG-A104/24VAC	
24 V DC / ± 20% / 1.9 W	ISG-A104/24VDC	
Accessories	Order code	Page
Protective enclosure	PanBox 1x1	78
11-pole DIN-socket	ISO1	85
Retaining clip	RTC 11	85

Technical data (at 20°C)

Operating voltage	see purchase order table
Operating basis	modulated infrared light
Transmit frequency	3.7 kHz / 3.85 kHz / 3.97 kHz / 4.1 kHz
Transmit power	automatic
Basic transmit level	low1 / low2 / high1 / high2
Switching behaviour	light / dark
Switching delay	—
Multiplex speed	—
Master/Slave operation	—
Teach function	—
Switching output	relay, change over
Operation values (max.)	5 A / 230 V AC (24 V DC)
Reaction time	25 ms / 52 ms (Basic transmit level: low / high)
Alarm output	PNP
Operation values (max.) ...AC	5 mA / 24 V DC
Operation values (max.) ...DC	100 mA / 24 V DC
Test input	—
Analog output	—
COM-Interface	—
Housing material	plastic
Protection class (EN 60529)	IP 40
Connection	11-pole DIN-plug
Operating temperature	-25 °C ... 50 °C
Dimensions (W x H x D)	40 x 76.5 x 78.5 mm see picture 12 on page 56

Device description

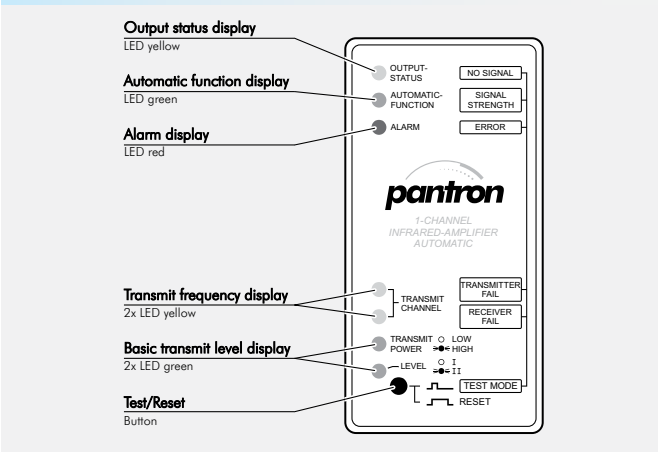

Amplifier mode (factory setting is marked white)

ON	Basic transmit level		Transmit frequency		
	1	2	3	4	
high2	ON	ON	4.10 kHz	ON	ON
high1	ON	OFF	3.97 kHz	ON	OFF
low2	OFF	ON	3.85 kHz	OFF	ON
low1	OFF	OFF	3.70 kHz	OFF	OFF

For more detailed information see www.pantron.com

Maximum Range (through beam)

	Receiver IRL-...	Receiver IR-...
Transmitter IT-..., ITL-...	7 m	15 m
Transmitter IT-...HP, ITH-...	10 m	25 m
Transmitter ITA-...	20 m	50 m

Connection diagram

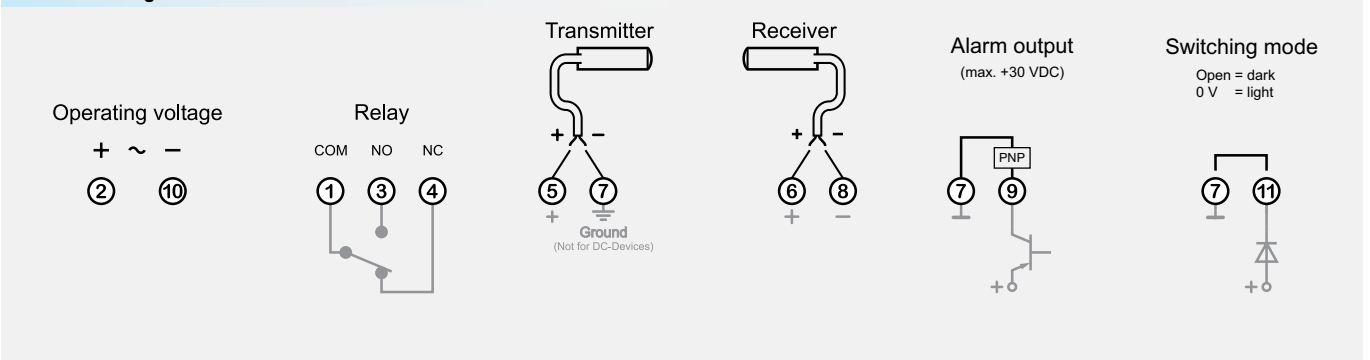



2-channel multiplex amplifier ICL-2000

- Detection range up to 35 m
- Manual / automatic operation selectable
- Switching behaviour light / dark selectable
- Switching outputs, PNP - short circuit proof
- Alarm output for power limit
- Analog output 0 - 10 V DC
- Test button with diagnostic function
- Test input for system check
- Sensor control
- COM Interface (RS232) - configuration with personal computer
- Master/Slave operation
- Mounting for DIN rail (EN 60715)

Technical data (at 20 °C)

Operating voltage	24 V DC / ±20% / 3.6 W
Operating basis	modulated infrared light
Transmit frequency	4.0 kHz
Transmit power	manual / automatic
Basic transmit level	low1 / low2 / high1 / high2
Switching behaviour	light / dark
Switching delay	—
Multiplex speed	10 ms
Master/Slave operation	yes
Switching output	2x PNP, short circuit proof
Operation values (max.)	100 mA / 24 V DC
Reaction time	12 ms
Alarm output	PNP, short circuit proof
Operation values (max.)	100 mA / 24 V DC
Test input	max. 30 V DC / 2 mA
Operate voltage	Low < 5 V DC; High > 15 V DC
Analog output	0 ... 10 V DC
COM-Interface	RS232
Housing material	Polyamide
Protection class (EN 60529)	IP 00
Connection	Phoenix Contact Typ MCV 1,5/8-G-3,81
Operating temperature	-25 °C ... 50 °C
Dimensions (W x H x D)	73 x 111 x 55 mm see picture 16 on page 56

For more detailed information see www.pantron.com

Maximum Range (through beam)

	Receiver IRL-...	Receiver IR-...
Transmitter IT-..., ITL-...	4 m	12 m
Transmitter IT-...HP, ITH-...	7 m	19 m
Transmitter ITA-...	12 m	35 m

Connection diagram

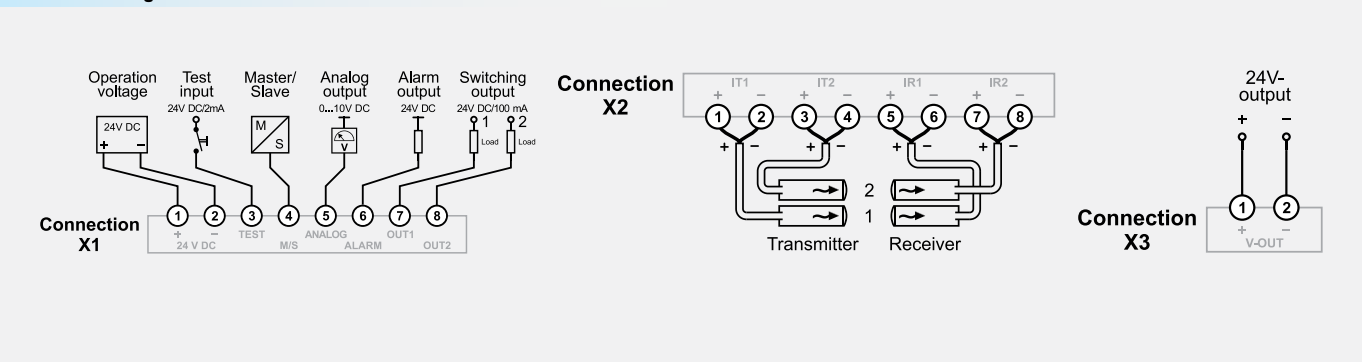

Purchase order table

Connection	Order code	
Plug (spring clamp terminals)	ICL-2000/24VDC	
Accessories	Order code	Page
Protective enclosure	PanBox 1x2	78
Power supply PSU-1000	PSU-1000S/95...265VAC	80
Communication cable	CAB-COM-2	84
PC software	WinICL	85

Device description

The light barrier amplifier ICL-2000 is a two-channel amplifier with an open frame housing and automatic operation, rated in four basic transmit levels. Because of the special parameter settings and other properties, this amplifier is especially suited for vehicle wash applications.

Additional features:

- Programmable DIP switch functions (choice of different basic settings)
- Essential higher insensitivity to ambient light (insensitivity to solar radiation, spotlights, etc.), DE/EU/US-Patents

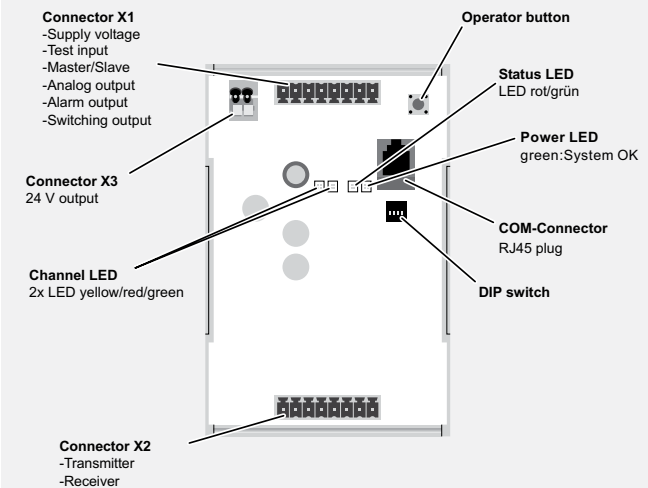

6-channel multiplex amplifier ICL-6000

- Detection range up to 35 m
- Manual / automatic operation selectable
- Switching behaviour light / dark selectable
- Switching outputs, PNP - short circuit proof
- Alarm output for power limit
- Analog output 0 - 10 V DC
- Test button with diagnostic function
- Test input for system check
- Sensor control
- COM Interface (RS232) - configuration with personal computer
- Master/Slave operation
- Mounting for DIN rail (EN 60715)

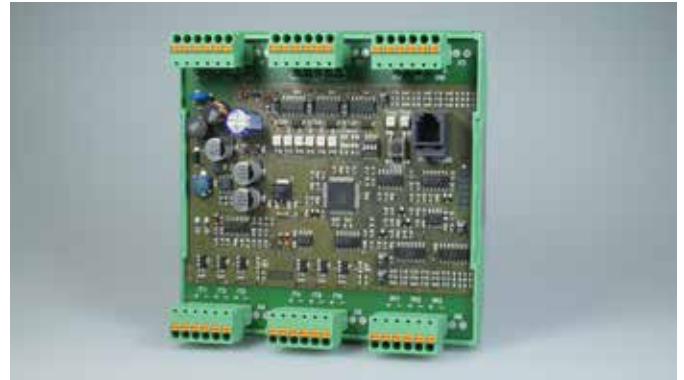

Purchase order table

Connection	Order code	
Plug (spring clamp terminals)	ICL-6000/24VDC	
Accessories	Order code	Page
Protective enclosure	PanBox 1x8	79
Power supply PSU-1000	PSU-1000S/95...265VAC	80
Communication cable	CAB-COM-2	84
PC software	WinICL	85

Device description

The light barrier amplifier ICL-6000 is a six-channel amplifier with an open frame housing and automatic operation, rated in four basic transmit levels. Because of the special parameter settings and other properties, this amplifier is especially suited for vehicle wash applications.

Additional features:

- Programmable DIP switch functions (choice of different basic settings)
- Essential higher insensitivity to ambient light (insensitivity to solar radiation, spotlights, etc.), DE/EU/US-Patents

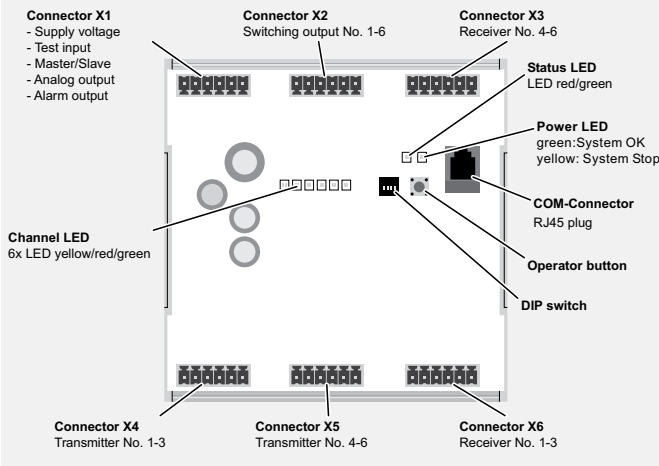

Technical data (at 20 °C)

Operating voltage	24 V DC / $\pm 20\%$ / 4.2 W
Operating basis	modulated infrared light
Transmit frequency	4.0 kHz
Transmit power	manual / automatic
Basic transmit level	low1 / low2 / high1 / high2
Switching behaviour	light / dark
Switching delay	—
Multiplex speed	34 ms
Master/Slave operation	yes
Switching output	6x PNP, short circuit proof
Operation values (max.)	100 mA / 24 V DC
Reaction time	36 ms
Alarm output	PNP, short circuit proof
Operation values (max.)	100 mA / 24 V DC
Test input	max. 30 V DC / 2 mA
Operate voltage	Low < 5 V DC; High > 15 V DC
Analog output	0 ... 10 V DC
COM-Interface	RS232
Housing material	Polyamide
Protection class (EN 60529)	IP 00
Connection	Phoenix Contact Typ MCV 1,5/6-G-3,81
Operating temperature	-25 °C ... 50 °C
Dimensions (W x H x D)	111 x 111 x 55 mm see picture 17 on page 56

For more detailed information see www.pantron.com

Maximum Range (through beam)

	Receiver IRL-...	Receiver IR-...
Transmitter IT-..., ITL-...	5 m	15 m
Transmitter IT-...HP, ITH-...	8 m	20 m
Transmitter ITA-...	14 m	35 m

Connection diagram

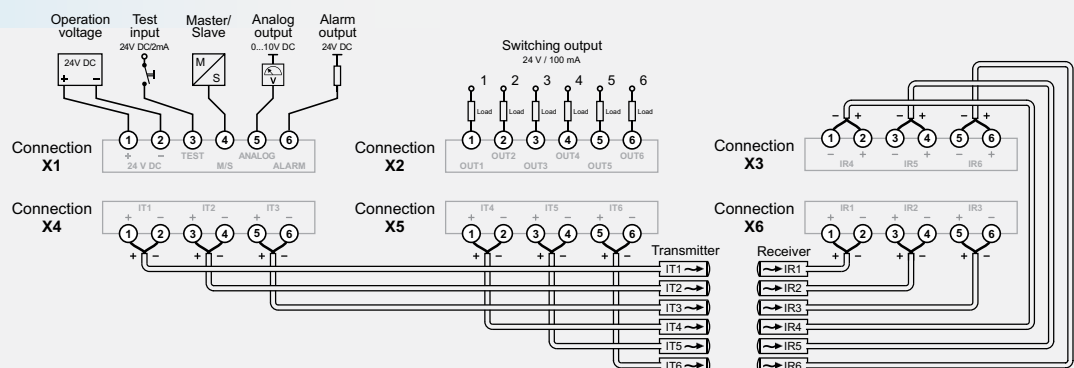

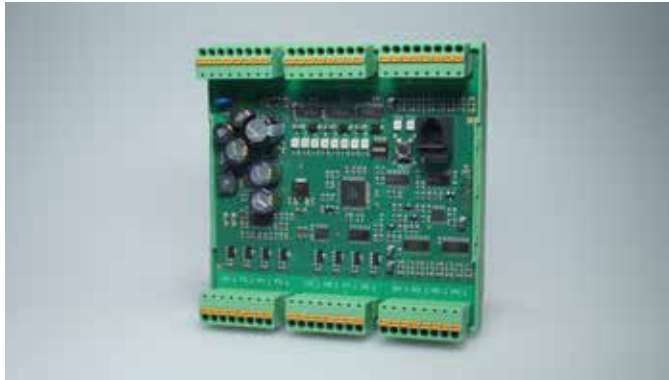

8-channel multiplex amplifier ICL-8000

- Detection range up to 35 m
- Manual / automatic operation selectable
- Switching behaviour light / dark selectable
- Switching outputs, PNP - short circuit proof
- Alarm output for power limit
- Analog output 0 - 10 V DC
- Test button with diagnostic function
- Test input for system check
- Sensor control
- COM Interface (RS232) - configuration with personal computer
- Master/Slave operation
- Mounting for DIN rail (EN 60715)

Technical data (at 20 °C)

Operating voltage	24 V DC / ±20% / 3.6 W
Operating basis	modulated infrared light
Transmit frequency	4.0 kHz
Transmit power	manual / automatic
Basic transmit level	low1 / low2 / high1 / high2
Switching behaviour	light / dark
Switching delay	—
Multiplex speed	34 ms
Master/Slave operation	yes
Switching output	8x PNP, short circuit proof
Operation values (max.)	100 mA / 24 V DC
Reaction time	36 ms
Alarm output	PNP, short circuit proof
Operation values (max.)	100 mA / 24 V DC
Test input	max. 30 V DC / 2 mA
Operate voltage	Low < 5 V DC; High > 15 V DC
Analog output	0 ... 10 V DC
COM-Interface	RS232
Housing material	Polyamide
Protection class (EN 60529)	IP 00
Connection	Phoenix Contact Typ MCV 1,5/8-G-3,81
Operating temperature	-25 °C ... 50 °C
Dimensions (W x H x D)	111 x 111 x 55 mm see picture 17 on page 56

For more detailed information see www.pantron.com

Maximum Range (through beam)

	Receiver IRL-...	Receiver IR-...
Transmitter IT-..., ITL-...	4 m	12 m
Transmitter IT-...HP, ITH-...	7 m	19 m
Transmitter ITA-...	12 m	35 m

Connection diagram

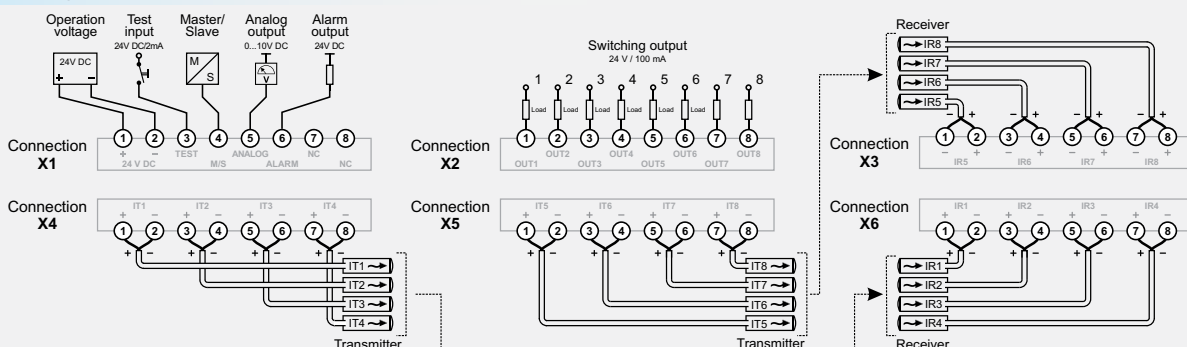

Purchase order table

Connection	Order code	
Plug (spring clamp terminals)	ICL-8000/24VDC	
Accessories	Order code	Page
Protective enclosure	PanBox 1x8	79
Power supply PSU-1000	PSU-1000S/95...265VAC	80
Communication cable	CAB-COM-2	84
PC software	WinICL	85

Device description

The light barrier amplifier ICL-8000 is an eight-channel amplifier with an open frame housing and automatic operation, rated in four basic transmit levels. Because of the special parameter settings and other properties, this amplifier is especially suited for vehicle wash applications.

Additional features:

- Programmable DIP switch functions (choice of different basic settings)
- Essential higher insensitivity to ambient light (insensitivity to solar radiation, spotlights, etc.), DE/EU/US-Patents

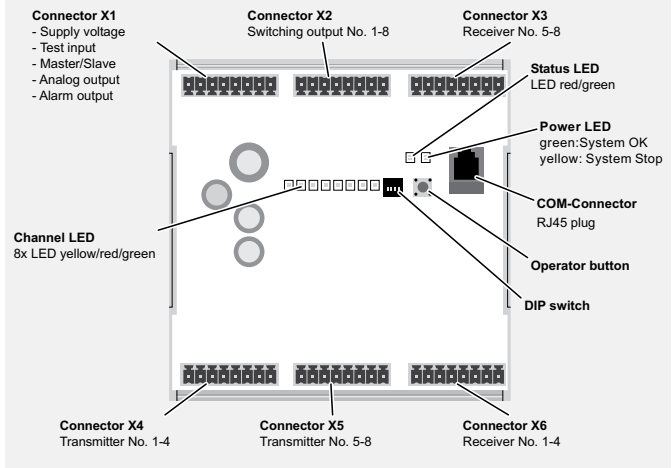

Dimension drawings (in mm)

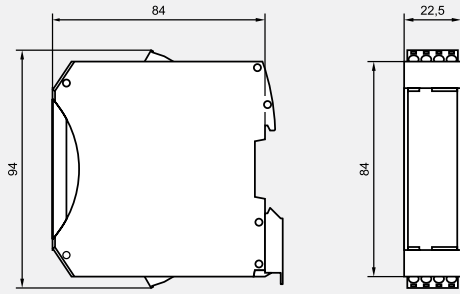

picture 1: ISM-15x0, ISM-15x5

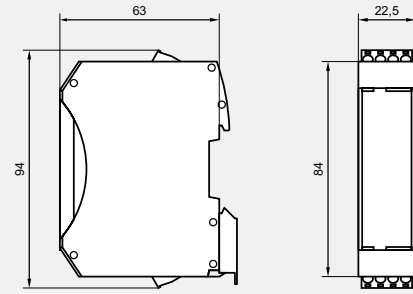

picture 2: ISM-1516

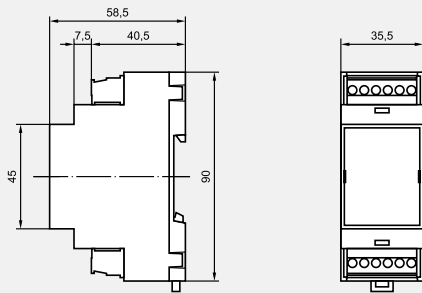

picture 3: ISM-1x00

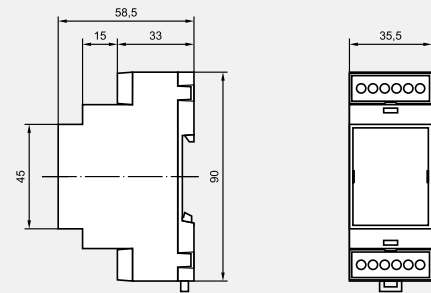

picture 4: ISM-1x00S, PSU-1000S

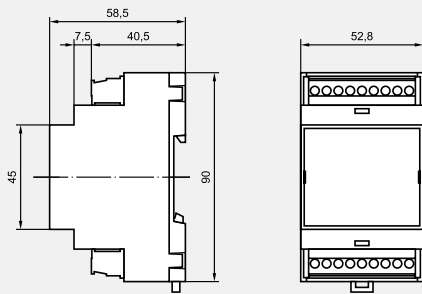

picture 5: ISM-2x00

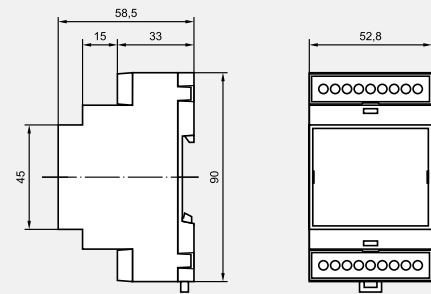

picture 6: ISM-1220S, ISM-2000S, PSU-1200S

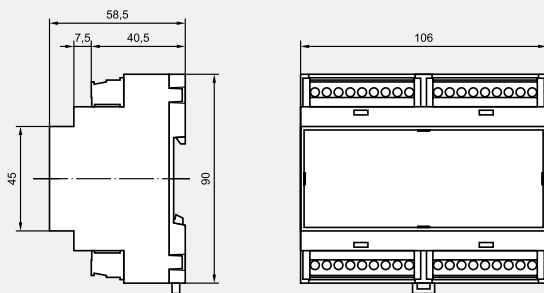

picture 7: ISM-4x00

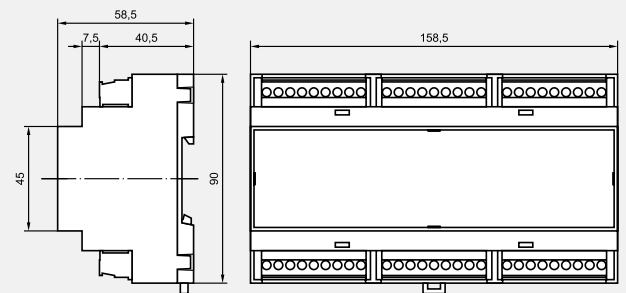

picture 8: ISM-8x00, ISL-8000

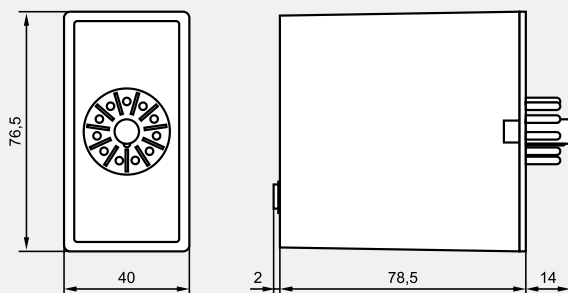

picture 9: ISG-N14

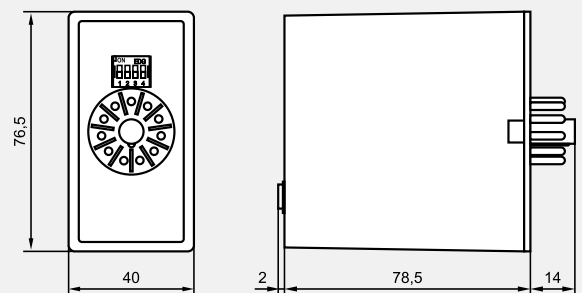

picture 10: ISG-N2x, ISG-N3x, ISG-N1xx

Dimension drawings (in mm)

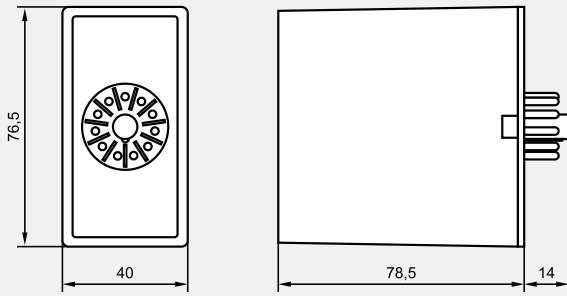

picture 11: ISG-A103, ISG-A11x

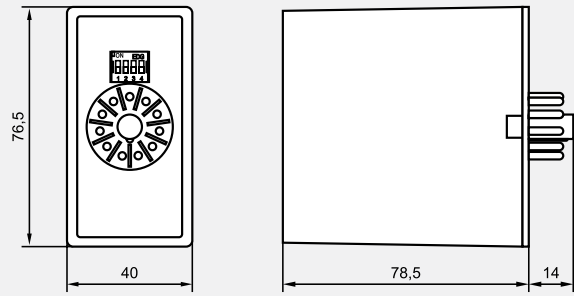

picture 12: ISG-A12x, ISG-A13x, ISG-A14x, IMX-Nxx

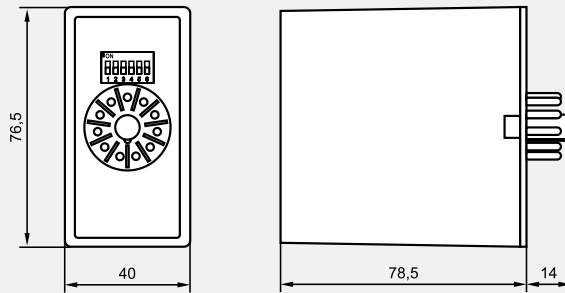

picture 13: IMX-A20xx

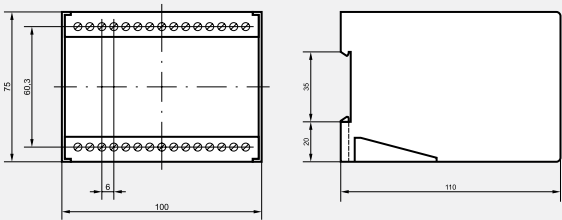

picture 14: IMX-N4x0

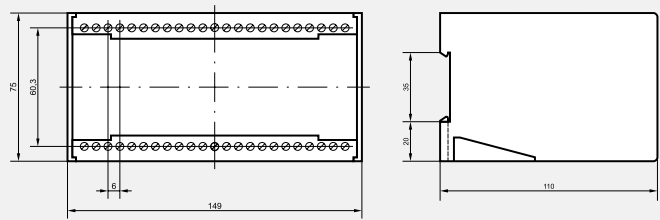

picture 15: IMX-N8x0, IMX-A8xx

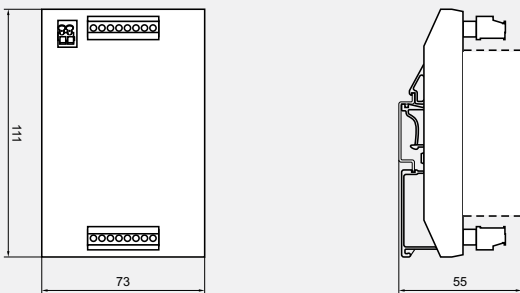

picture 16: ICL-2x00

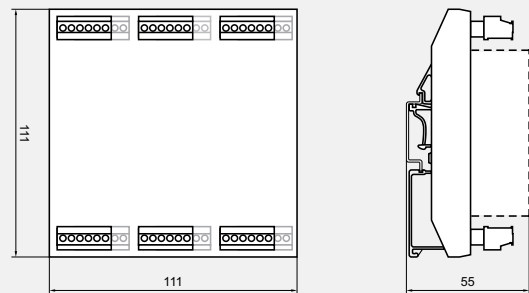

picture 17: ICL-6x00, ICL-8x00

Sensors



Overview

Technical Data (at 20 °C)	S. 58
Range overview	S. 58
Connection diagram	S. 58
Product overview	S. 59
Dimension drawings (in mm)	S. 60

Sensors IR... / IT...

- Extremely dirt-resistant
- High penetration
- Large detection range
- Small design
- High switching accuracy
- Easy adjustment
- Cable or plug connection



Note

The sensors IR... / IT... from Pantron can be used only with the amplifier type ISM-..., ISG-..., IMX-... or ICL-...

Accessories - see pages 84 - 85

Technical Data (at 20 °C)			
General			
Ambient temperature	-25 °C ... 65 °C		
Storage temperature	-40 °C ... 80 °C		
Vibration	10 ... 55 Hz, 1.5 mm		
Shock	30 g		
Protection class	IP 67		
Transmitter			
Type	IT-..., ITL-...	IT-...HP..., ITH-...	ITA-...
Transmit light	Infrared 880 nm, modulated	Infrared 870 nm, modulated	Infrared 870 nm, modulated
Transmit power (IF = 100 mA)	40 mW/sr	70 mW/sr	350 mW/sr
Opening angle	± 5 °	± 10 °	± 3 °
Cable sheathing	PVC, Ø 3.8 mm ± 0.2 mm, black ¹		
Cable core construction	2x 0.25 mm, red / black		
Receiver			
Type	IRL-...	IR-...	IR-...
Opening angle	± 12 °	± 12 °	± 12 °
Ambient light immunity	40000 LUX		60000 LUX
Cable sheathing	PVC, Ø 3.8 mm ± 0.2 mm, black ¹		
Cable core construction	1x 0.34 mm, yellow shielded		

Range overview (different sensor-amplifier combinations)

		Sensors						
		Transmitter	IT-... / ITL-...		IT-...HP... / ITH-...		ITA-...	
		Receiver	IRL-...	IR-...	IRL-...	IR-...	IRL-...	IR-...
Amplifier	ISM-Series	ISM-1200	7 m	15 m	10 m	25 m	20 m	55 m
		ISM-1220	8 m	15 m	10 m	20 m	20 m	50 m
		ISM-15xx	20 m	25 m	30 m	35 m	50 m	70 m
		ISM-2x00	8 m	20 m	10 m	30 m	20 m	55 m
		ISM-4x00 / ISM-8x00	10 m	15 m	12 m	25 m	25 m	60 m
	ISG-Series	ISG-Nxx	20 m	25 m	30 m	35 m	50 m	70 m
		ISG-N124M	10 m	20 m	20 m	35 m	35 m	55 m
		ISG-N1xx	10 m	20 m	20 m	35 m	35 m	55 m
		ISG-A1xx	7 m	15 m	10 m	25 m	20 m	50 m
	IMX-Series	IMX-Nxx	10 m	20 m	15 m	30 m	25 m	50 m
		IMX-N4x0 / IMX-N8x0	10 m	20 m	15 m	30 m	20 m	40 m
		IMX-A20xx	7 m	13 m	9 m	20 m	15 m	40 m
		IMX-A8xx	8 m	15 m	10 m	20 m	20 m	55 m



















Connection diagram

Cable version				Plug version			
Transmitter	Transmitter	Transmitter	Transmitter	Transmitter	Transmitter	Transmitter	Transmitter
Core colour	Connection	Core colour	Connection	PIN	Connection	PIN	Connection
red	+	yellow	+	① (brown) ²	+	④ (black) ²	+
black	-	shield	-	③ (blue) ²	-	③ (blue) ²	-

¹ Other cable materials by request

² Core colour from the connection cable CAB-M... (see page 84)

Product overview

Order code				Connection	Material	Outline drawing	Picture
Transmitter IT-..., ITL-...	Transmitter IT-...HP..., ITH-...	Transmitter ITA-...	Receiver IR-..., IRL-...				
IT-P10-5 IT-P10-15	IT-P10HP-5 IT-P10HP-15	ITA-TLP-5 ITA-TLP-15	IR-P10-5 IR-P10-15	cable 5m ¹ cable 15m ¹	plastic	picture 1	
IT-P10-3QD	IT-P10HP-3QD	ITA-TLP-B3	IR-P10-3QD	Plug M8	plastic	picture 2	
IT-M12-5 IT-M12-15	IT-M12HP-5 IT-M12HP-15	ITA-CLN-5 ITA-CLN-15	IR-M12-5 IR-M12-15	cable 5m ¹ cable 15m ¹	nickel plated brass	picture 3	
IT-M12VA-5 IT-M12VA-15	IT-M12VAHP-5 IT-M12VAHP-15	ITA-CLV-5 ITA-CLV-15	IR-M12VA-5 IR-M12VA-15	cable 5m ¹ cable 15m ¹	stainless steel		
IT-M12-3QD	IT-M12HP-3QD	ITA-CLN-B3	IR-M12-3QD	plug M8	nickel plated brass	picture 4	
IT-M12VA-3QD	IT-M12VAHP-3QD	ITA-CLV-B3	IR-M12VA-3QD	plug M8	stainless steel		
IT-M12-4QD	IT-M12HP-4QD	ITA-CLN-C4	IR-M12-4QD	plug M12	nickel plated brass	picture 5	
IT-M12VA-4QD	IT-M12VAHP-4QD	ITA-CLV-C4	IR-M12VA-4QD	plug M12	stainless steel		
IT-AS-5 IT-AS-15				cable 5m ¹ cable 15m ¹	plastic	picture 6	
			IR-AS-5 IR-AS-15	cable 5m ¹ cable 15m ¹	plastic	picture 7	
IT-AS-3QD				plug M8	plastic	picture 8	
			IR-AS-3QD	plug M8	plastic	picture 9	
IT-SLA-5 IT-SLA-15	IT-SLAHP-5 IT-SLAHP-15	ITA-LLA-5 ITA-LLA-15	IR-SLA-5 IR-SLA-15	cable 5m ¹ cable 15m ¹	aluminium	picture 10	
IT-SLA-3QD	IT-SLAHP-3QD	ITA-LLA-B3	IR-SLA-3QD	plug M8	aluminium	picture 11	
ITL-TSP-5 ITL-TSP-15	ITH-TSP-5 ITH-TSP-15	ITA-TSP-5 ITA-TSP-15	IRL-TSP-5 IRL-TSP-15	cable 5m ¹ cable 15m ¹	plastic	picture 12	
ITL-TSP-B3	ITH-TSP-B3	ITA-TSP-B3	IRL-TSP-B3	plug M8	plastic	picture 13	
ITL-SSP-5 ITL-SSP-15	ITH-SSP-5 ITH-SSP-15	ITA-SSP-5 ITA-SSP-15	IRL-SSP-5 IRL-SSP-15	cable 5m ¹ cable 15m ¹	plastic	picture 14	
ITL-SSP-B3	ITH-SSP-B3	ITA-SSP-B3	IRL-SSP-B3	plug M8	plastic	picture 15	
ITL-CSN-5 ITL-CSN-15	ITH-CSN-5 ITH-CSN-15	ITA-CSN-5 ITA-CSN-15	IRL-CSN-5 IRL-CSN-15	cable 5m ¹ cable 15m ¹	nickel plated brass	picture 16	
ITL-CSV-5 ITL-CSV-15	ITH-CSV-5 ITH-CSV-15	ITA-CSV-5 ITA-CSV-15	IRL-CSV-5 IRL-CSV-15	cable 5m ¹ cable 15m ¹	stainless steel		
ITL-CSN-B3	ITH-CSN-B3	ITA-CSN-B3	IRL-CSN-B3	plug M8	nickel plated brass	picture 17	
ITL-CSV-B3	ITH-CSV-B3	ITA-CSV-B3	IRL-CSV-B3	plug M8	stainless steel		
ITL-CSN-C4	ITH-CSN-C4	ITA-CSN-C4	IRL-CSN-C4	plug M12	nickel plated brass	picture 18	
ITL-CSV-C4	ITH-CSV-C4	ITA-CSV-C4	IRL-CSV-C4	plug M12	stainless steel		

¹ Other cable lengths by request

Dimension drawings (in mm)

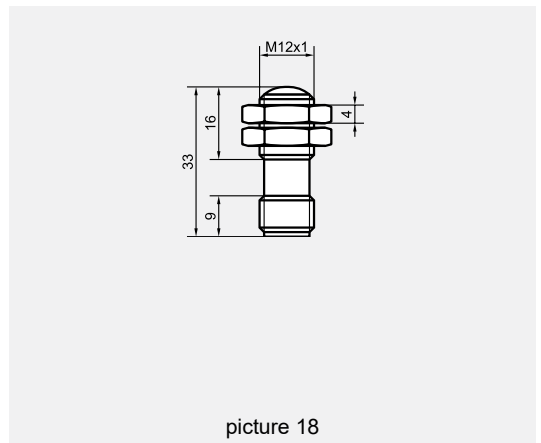
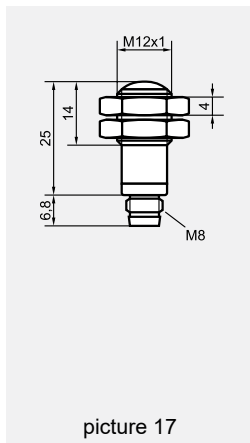
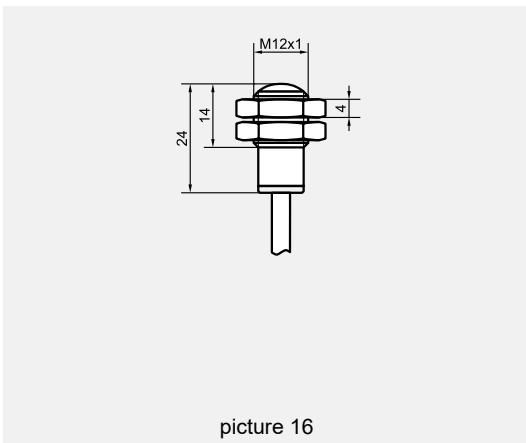
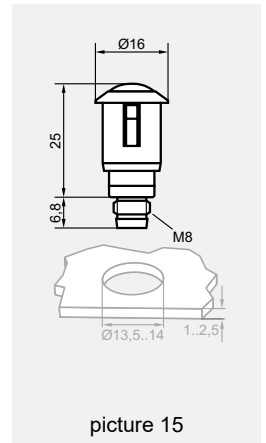
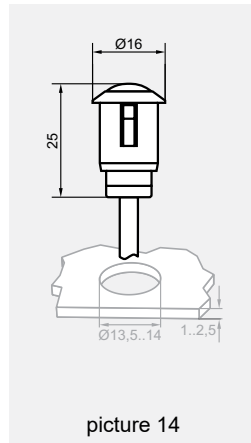
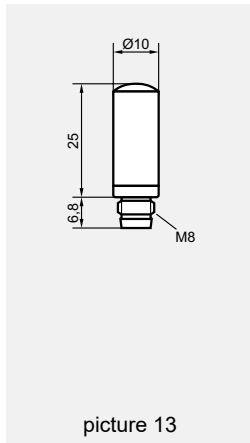
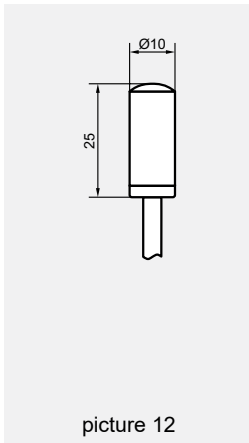
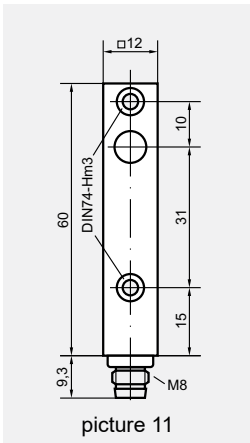
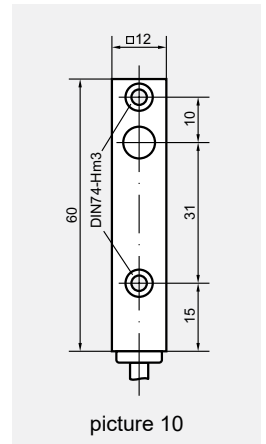
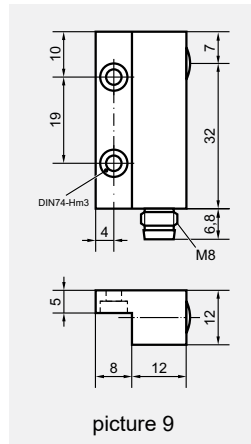
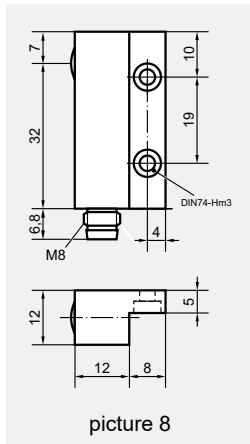
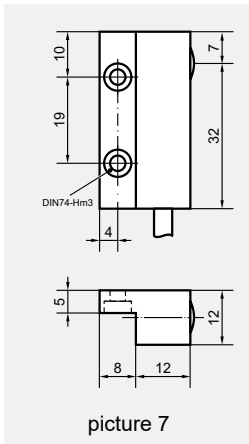
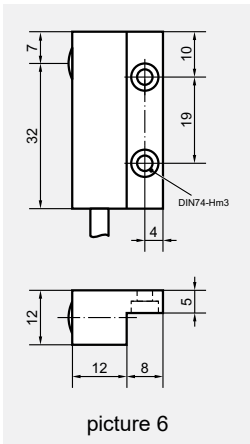
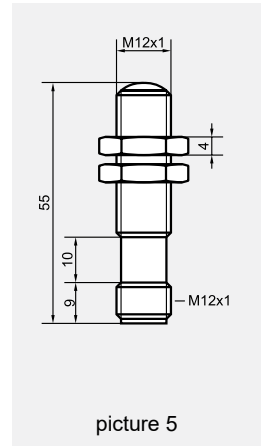
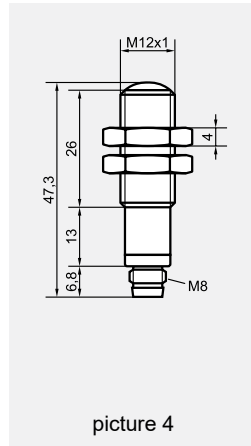
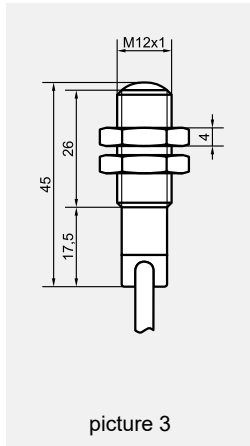
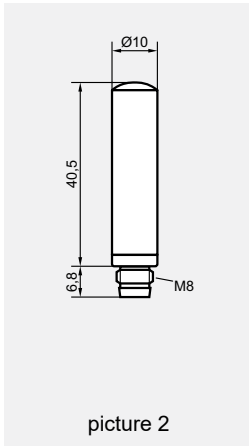
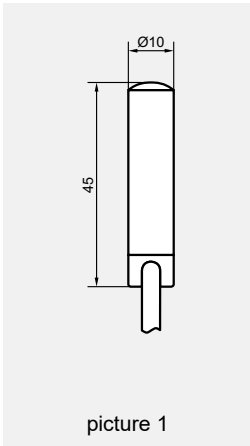

Safety light barrier



Overview

Safety light barrier amplifier ISL-8000	S. 62
Safety sensors ISR-... / IST-...	S. 63
Product overview (Safety sensors)	S. 64

Safety light barrier



Safety light barrier amplifier ISL-8000

- Contactless protective device (BWS) according to EN 61496-1/2
- Amplifier with up to 8 light barriers
- No influence between the light barriers
- Detection range up to 25 m
- One safety-output per light barrier
- Integrated diagnostic and alignment function
- COM Interface (USB) - configuration with personal computer
- Mounting to DIN rail (EN 60715)

Technical Data (at 20 °C, 24 V DC)

Operating voltage	24 V DC / ±20%
Current consumption ($I_{OUT} = 100 \text{ mA}$)	max. 1.4 A
Operating basis	modulated infrared light
Transmit frequency	4.0 kHz
Overall reaction time	≤ 36 ms
Detectability	Ø ≥ 10 mm
Maximum Range (through beam)	0.3 ... 25 m
Self-test cycle time	4.4 min
Master/Slave operation	—
Safety outputs	8x PNP (OSSD1) / 1x PNP (OSSD2)
Operation values (max.)	100 mA / 24 V DC
Functional outputs	2x PNP / NPN, push-pull
Operation values (max.)	100 mA / 24 V DC
Test input	max. 30 V DC / 2 mA
COM-Interface	USB
Housing material	NORYL, grey
Maximum cable length	50 m
Protection class (EN 60529)	IP 20
Connection	plug with screw terminals
Wire size	0.14 ... 2.5 mm ²
Operating temperature	-10 °C ... 50 °C
Dimensions (W x H x D)	158.5 x 90 x 58.5 mm see picture 8 on page 55

For more detailed information see www.pantron.com

Purchase order table

Type	Order code
ISL-8000	ISL-8000/24VDC

Accessories	Order code	Page
Protective enclosure	PanBox 1x8	79
PC software	WinISL	85

System description

The Safety-Light-Barrier-Amplifier ISL-8000, in conjunction with optical safety-transmitters and safety-receivers, yields a contactless protective device (BWS) according to EN61496 Part 1 and Part 2.

Every couple of sensors consisting of an optical safety-transmitter IST-... and an optical safety-receiver ISR-... forms a powerful light barrier whereby up to eight independent light barrier routes may be realized without mutual interference.

The amplifier evaluates each single light-barrier route and reports the status, interrupted or clear, via one of the eight outputs OSSD1 to the superior control system. The integrity of the connection to the control system may be evaluated by using internal or external testing.

To reduce service effort and to equalize changing environmental conditions (e.g. sensor contamination), the transmit-power of every individual channel is constantly adjusted by the automatic power regulation.

Applications

This system was specially developed for areas of application in which traditional light curtains cannot be used because of their design.

Device description

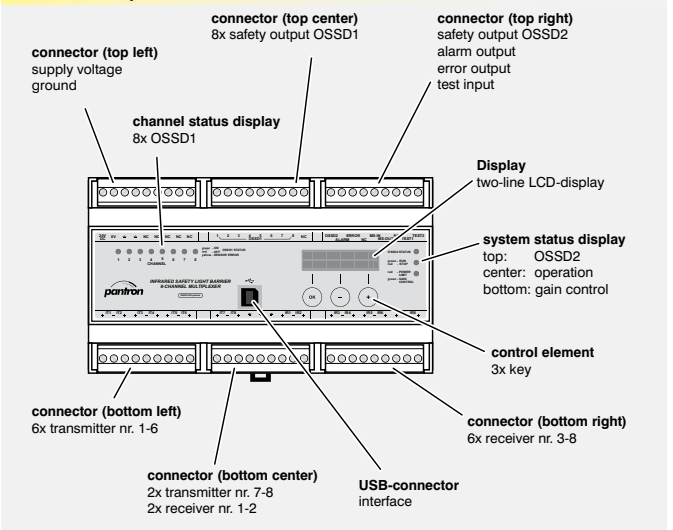

Connection diagram

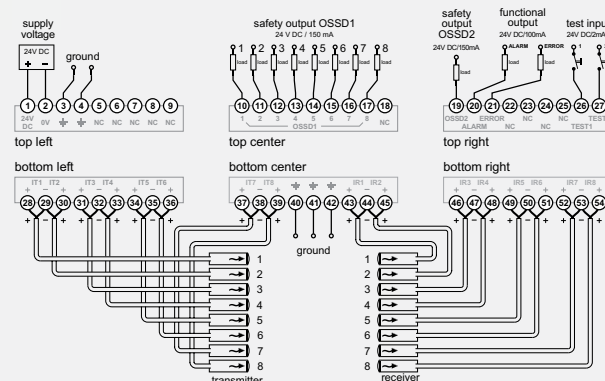

Safety sensors ISR-... / IST-...

- Extremely dirt-resistant
- High penetration
- Large detection range
- Small design
- High switching accuracy
- Cable or plug connection



Note

The sensors ISR-... und IST-... from Pantron can be used with the safety light barrier amplifier type ISL-8000.

Technical Data (at 20 °C)

General

Ambient temperature	-20 °C ... 60 °C
Storage temperature	-40 °C ... 80 °C
Vibration	10 ... 55 Hz, 1.5 mm
Shock	30 g
Protection class	IP 67

Transmitter

Type	IST-...
Transmit light	Infrared 880 nm, modulated
Transmit angle	± 5 °
Cable sheathing	PVC, Ø 3.8 mm ± 0.2 mm, black ¹
Cable core construction	2x 0.25 mm, red / black

Receiver

Type	ISR-...
Opening angle	± 5 °
Ambient light immunity	60.000 LUX
Cable sheathing	PVC, Ø 3.8 mm ± 0.2 mm, black ¹
Cable core construction	1x 0.34 mm, yellow shielded

Connection diagram















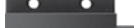

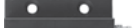

Cable version				Plug version			
Transmitter		Transmitter		Transmitter		Transmitter	
Core colour	Connection	Core colour	Connection	PIN	Connection	PIN	Connection
red	+	yellow	+	① (brown) ²	+	④ (black) ²	+
black	-	shield	-	③ (blue) ²	-	③ (blue) ²	-

¹ Other cable materials by request

² Core colour from the connection cable CAB-M... (see page 84)

Safety light barrier

Product overview (Safety sensors)

Transmitter (Order code)	Receiver (Order code)	Connection	Material	Dimensions see page 60	Picture
IST-TLP-5 IST-TLP-15	ISR-TLP-5 ISR-TLP-15	cable 5m ¹ cable 15m ¹	plastic	picture 1	
IST-TLP-B3	ISR-TLP-3QD	plug M8	plastic	picture 2	
IST-CLN-5 IST-CLN-15	ISR-CLN-5 ISR-CLN-15	cable 5m ¹ cable 15m ¹	nickel plated brass	picture 3	
IST-CLV-5 IST-CLV-15	ISR-CLV-5 ISR-CLV-15	cable 5m ¹ cable 15m ¹	stainless steel		
IST-CLN-B3	ISR-CLN-B3	plug M8	nickel plated brass	picture 4	
IST-CLV-B3	ISR-CLV-B3	plug M8	stainless steel		
IST-CLN-C4	ISR-CLN-C4	plug M12	nickel plated brass	picture 5	
IST-CLV-C4	ISR-CLV-C4	plug M12	stainless steel		
IST-KLP-5 IST-KLP-15		cable 5m ¹ cable 15m ¹	plastic	picture 6	
	ISR-KLP-5 ISR-KLP-15	cable 5m ¹ cable 15m ¹	plastic	picture 7	
IST-KLP-B3		plug M8	plastic	picture 8	
	ISR-KLP-B3	plug M8	plastic	picture 9	
IST-LLA-5 IST-LLA-15	ISR-LLA-5 ISR-LLA-15	cable 5m ¹ cable 15m ¹	aluminium	picture 10	
IST-LLA-B3	ISR-LLA-3QD	plug M8	aluminium	picture 11	
IST-TSP-5 IST-TSP-15		cable 5m ¹ cable 15m ¹	plastic	picture 12	
IST-TSP-B3		plug M8	plastic	picture 13	
IST-SSP-5 IST-SSP-15		cable 5m ¹ cable 15m ¹	plastic	picture 14	
IST-SSP-B3		plug M8	plastic	picture 15	
IST-CSN-5 IST-CSN-15		cable 5m ¹ cable 15m ¹	nickel plated brass	picture 16	
IST-CSV-5 IST-CSV-15		cable 5m ¹ cable 15m ¹	stainless steel		
IST-CSN-B3		plug M8	nickel plated brass	picture 17	
IST-CSV-B3		plug M8	stainless steel		
IST-CSN-C4		plug M12	nickel plated brass	picture 18	
IST-CSV-C4		plug M12	stainless steel		

¹ Other cable lengths by request

Compact light barrier



Overview

Applications	S. 66
Range overview	S. 67
Transmitter ST... (cable version)	S. 68
Transmitter ST... (plug version)	S. 69
Receiver SR... (cable version)	S. 70
Receiver SR... (plug version)	S. 71

Description

Compact Light Barriers ...

... were specially developed for areas of application in which traditional photo-electric sensors reach their limits.

Extreme dirt resistance and a long range make them particularly suitable for most difficult applications. The system's high power guarantees excellent penetration, even in the case of extreme contamination. Chips, dust, flour, oil or muddy water are no longer an obstacle. They are perfectly suitable for use in the timber and paper industry, in car wash systems, for controlling bulk material, in elevators, for outdoor gate control, in the food processing industry and in many other applications.

Each system consists of a transmitter and a receiver, available separately in very compact and robust designs.

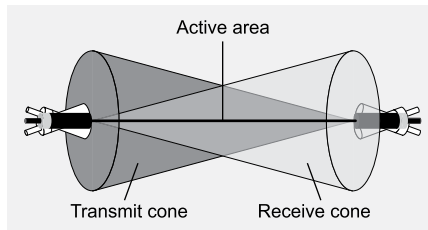

Thanks to their large field of view, they can be easily aligned, even at distances of 40 meters. Simultaneously, they are insensitive to shock, vibrations and a degree of misalignment.

The simple installation of the transmitter and receiver as well as the uncomplicated handling of the devices emphasize the high user friendliness.

The sensors can be mounted according to different operating principles as required:



Through beam

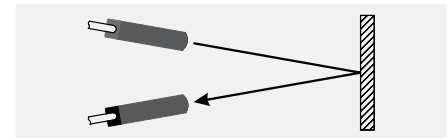

Retro reflective

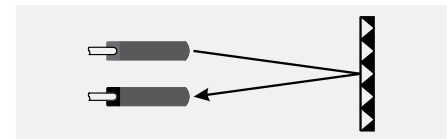

Diffuse proximity

Applications

Through beam light barrier

- Level control, e.g. harsh and dirty to control the levels of bulk material in silos.
- Gate control, e.g. in industrial sectional gates, also outdoor in rain, snow and fog.
- Door control, e.g. in passenger and industrial elevators.
- Position recognition, e.g. in extremely dusty environments, such as cement or gravel plants.

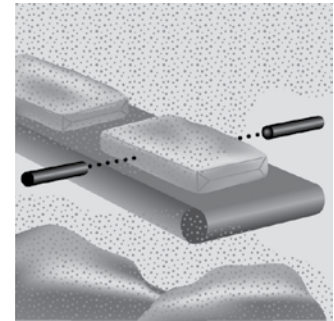
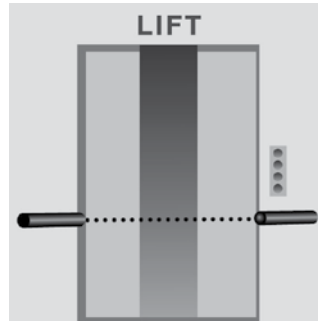
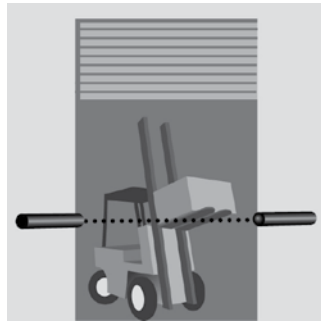
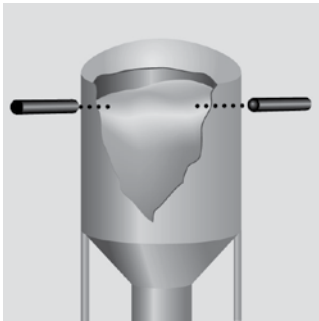

Diffuse proximity

- Objects detecting, e.g. from piece material.

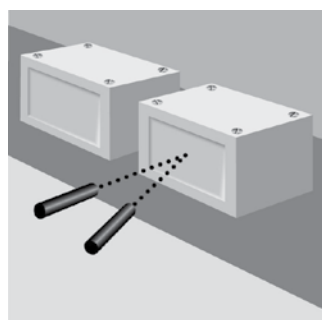

Retro reflective light barrier

- High control, e.g. on a conveyor belt.

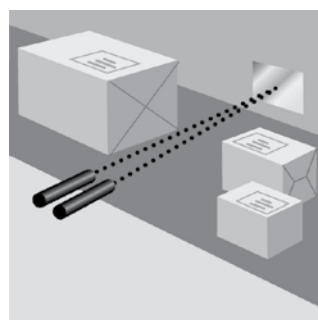

Safety instructions



The devices are not to be used for applications where personal safety is dependent on their function.

Do not look into the transmitter! It's possible, that highly concentrated non visible infrared light is emitting out of the transmitter STB..., which can be hazardous to the human eye. So you have to follow the safety precautions given in IEC 60825-1.

Range overview

			Transmitter	
			STA-...	STB-...
Receiver	light switching	SRSL...	1 m	5 m
		SRHL...	6 m	20 m
		SRLL...	15 m	40 m
	dark switching	SRSD...	1 m	5 m
		SRHD...	6 m	20 m
		SRLD...	15 m	40 m

Dimension drawings (in mm)

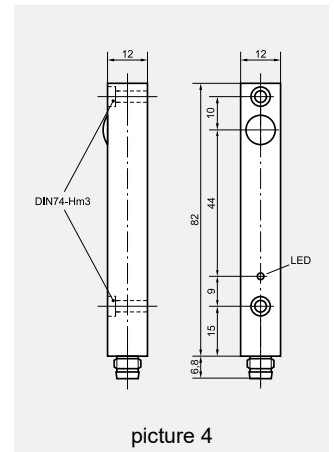
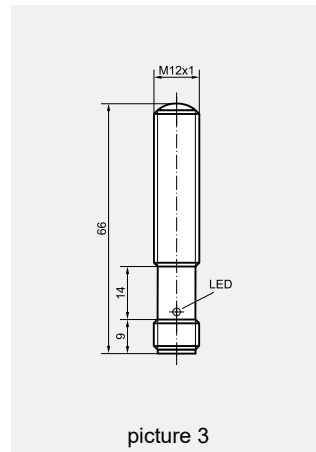
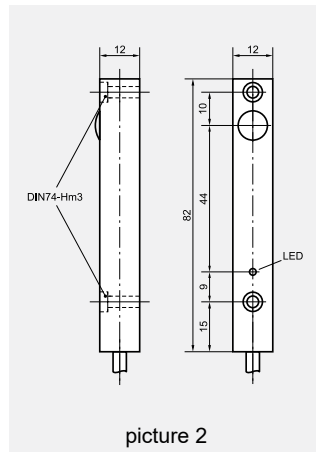
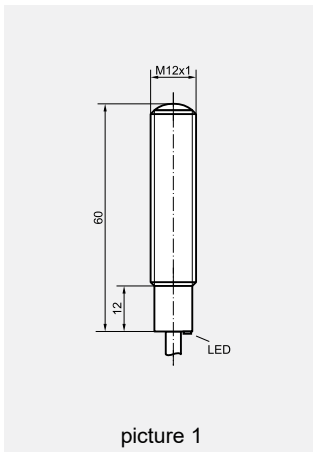

Compact light barrier

Transmitter ST... (cable version)

- Transmit power adjustment with external resistor
- Extremely dirt-resistant
- High penetration
- High range
- Small design
- Easy adjustment
- Cable connection



Technical Data (at 20 °C, 24 V DC)

Supply voltage	12 V DC ... 30 V DC		
Current consumption	30 mA		
Transmit light	infrared 880 nm, modulated		
Transmit angle STA-... / STB-...	20° / 6°		
Transmit frequency	11.7 kHz		
Transmit power	externally adjustable with resistor		
Housing material	nickel plated brass	stainless steel	aluminium anodized black
Cable material	PVC	PVC	PVC
Connection plug	—	—	—
Protection class	IP 67		
Operating temperature	-20 °C ... 60 °C		
Vibration	10 ... 55 Hz, 1.5 mm		
Shock	30 g		
Dimensions	see pictures 1 - 2 on page 67		

For more detailed information see www.pantron.com

Purchase order table (other cable length or cable materials by request)

Transmit angle 20°			
Connection cable 5 m	STA-CLN-5	STA-CLV-5	STA-LLA-5
Transmit angle 6°			
Connection cable 5 m	STB-CLN-5	STB-CLV-5	STB-LLA-5

Accessories	Page
Power supply PSU-1000 or PSU-1200	80 - 81
Glass fiber optic cable	84
Protective glass shield / Light shutter / Cleaning air nozzle	85

Connection diagram

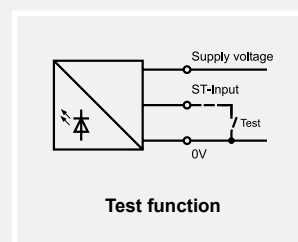
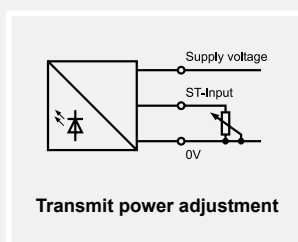
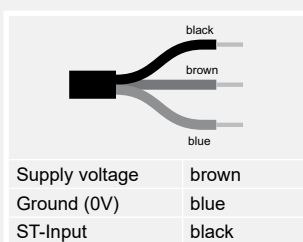

Transmitter ST... (plug version)

- Transmit power adjustment with external resistor
- Extremely dirt-resistant
- High penetration
- High range
- Small design
- Easy adjustment
- Plug connection



Technical Data (at 20 °C, 24 V DC)

Supply voltage	12 V DC ... 30 V DC		
Current consumption	30 mA		
Transmit light	infrared 880 nm, modulated		
Transmit angle STA-... / STB-...	20° / 6°		
Transmit frequency	11.7 kHz		
Transmit power	externally adjustable with resistor		
Housing material	nickel plated brass	stainless steel	aluminium anodized black
Cable material	—	—	—
Connection plug	M12	M12	M8
Protection class	IP 67		
Operating temperature	-20 °C ... 60 °C		
Vibration	10 ... 55 Hz, 1.5 mm		
Shock	30 g		
Dimensions	see pictures 3 - 4 on page 67		

For more detailed information see www.pantron.com

Purchase order table

Transmit angle 20°			
Connection plug	STA-CLN-C4	STA-CLV-C4	STA-LLA-B3
Transmit angle 6°			
Connection plug	STB-CLN-C4	STB-CLV-C4	STB-LLA-B3

Accessories	Page
Power supply PSU-1000 or PSU-1200	80 - 81
Connection cable CAB-M... / Glass fiber optic cable	84
Protective glass shield / Light shutter / Cleaning air nozzle	85

Connection diagram

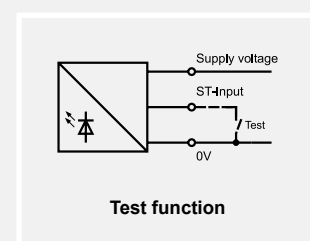
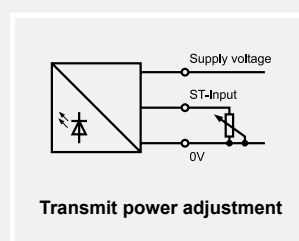
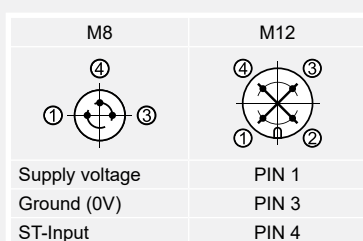

Compact light barrier

Receiver SR... (cable version)

- Transistor output NPN/PNP
- Extremely dirt-resistant
- High penetration
- Small design
- High switching accuracy
- Easy adjustment
- Switching behaviour light or dark
- Cable connection



Technical Data (at 20 °C, 24 V DC)

Maximum range	see range overview on page 67		
Supply voltage	12 V DC ... 30 V DC		
Current consumption	max. 30 mA		
Opening angle	12°		
Transistor output	NPN / PNP, push pull circuit		
Load	max. 100 mA		
Switching frequency	SRS... 500 Hz / SRH... 150 Hz / SRL... 25 Hz		
Ambient light immunity	60.000 LUX		
Housing material	nickel plated brass	stainless steel	aluminium anodized black
Cable material	PVC	PVC	PVC
Protection class	IP 67		
Operating temperature	-20 °C ... 60 °C		
Vibration	10 ... 55 Hz, 1.5 mm		
Shock	30 g		
Dimensions	see pictures 1 - 2 on page 67		

Purchase order table (other cable length or cable materials by request)

Switching behaviour	Max. range		Order code
	STA...	STB...	
Light switching	1 m	5 m	SRSL-CLN-5
	6 m	20 m	SRHL-CLN-5
	15 m	40 m	SRLL-CLN-5
Dark switching	1 m	5 m	SRSD-CLN-5
	6 m	20 m	SRHD-CLN-5
	15 m	40 m	SRLD-CLN-5

Accessories

Accessories	Page
Power supply PSU-1000 or PSU-1200	80 - 81
Glass fiber optic cable	84
Protective glass shield / Light shutter / Cleaning air nozzle	85

Connection diagram

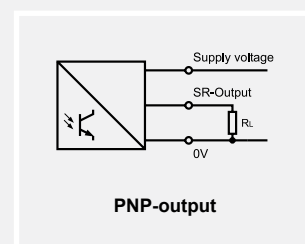
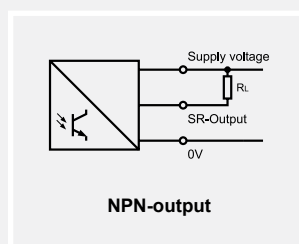
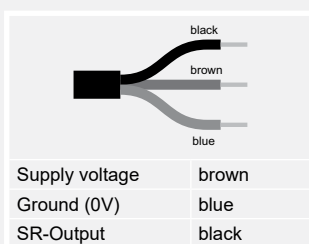

Receiver SR... (plug version)

- Transistor output NPN/PNP
- Extremely dirt-resistant
- High penetration
- Small design
- High switching accuracy
- Easy adjustment
- Switching behaviour light or dark
- Plug connection



Technical Data (at 20 °C, 24 V DC)			
Maximum Range	see range overview on page 67		
Supply voltage	12 V DC ... 30 V DC		
Current consumption	max. 30 mA		
Opening angle	12°		
Transistor output	NPN / PNP, push pull circuit		
Load	max. 100 mA		
Switching frequency	SRS... 500 Hz / SRH... 150 Hz / SRL... 25 Hz		
Ambient light immunity	60.000 LUX		
Housing material	nickel plated brass	stainless steel	aluminium anodized black
Connection plug	M12	M12	M8
Protection class	IP 67		
Operating temperature	-20 °C ... 60 °C		
Vibration	10 ... 55 Hz, 1.5 mm		
Shock	30 g		
Dimensions	see pictures 3 - 4 on page 67		

Purchase order table					
Switching behaviour	Max. range		Order code		
	STA...	STB...			
Light switching	1 m	5 m	SRSL-CLN-C4	SRSL-CLV-C4	SRSL-LLA-B3
	6 m	20 m	SRHL-CLN-C4	SRHL-CLV-C4	SRHL-LLA-B3
	15 m	40 m	SRLL-CLN-C4	SRLL-CLV-C4	SRLL-LLA-B3
Dark switching	1 m	5 m	SRSD-CLN-C4	SRSD-CLV-C4	SRSD-LLA-B3
	6 m	20 m	SRHD-CLN-C4	SRHD-CLV-C4	SRHD-LLA-B3
	15 m	40 m	SRLD-CLN-C4	SRLD-CLV-C4	SRLD-LLA-B3

Accessories	Page
Power supply PSU-1000 or PSU-1200	80 - 81
Connection cable CAB-M... / Glass fiber optic cable	84
Protective glass shield / Light shutter / Cleaning air nozzle	85

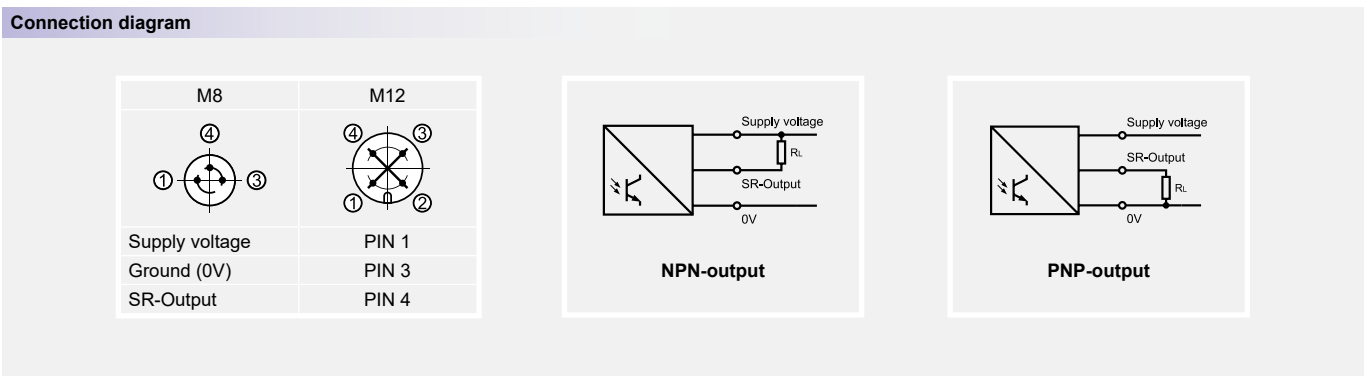

Fork light barrier



Overview

Fork light barrier FSI-... / FSR-...	S. 75
Dimension drawings (in mm)	S. 76

Fork light barrier

Fork light barriers with adjustable fork width ...

... are established sensors with a new concept. Until now, different applications required different fixed fork light barriers - high storage and procurement costs were the result. In the future, the complete fork width range from 5 to 85 mm and 5 to 145 mm can be covered with a single variable type.

The application possibilities are unlimited: the optimal adjustment of the fork width makes it possible to detect, for example, a small slot in a thin plate as well as an object on a conveyor belt. The modification of the fork depth and the maximum fork width is possible after the initial installation due to the modular design.

The automatic power adjustment with dirt compensation enables a fast and easy startup without further adjustments. The light barrier will adjust automatically to the selected fork width after switching on the power. Furthermore, the sensitivity automatically adjusts to overcome contamination of the optics.

For special applications, there are manual settings and a teach function.

An extra outstanding feature of this product series is the software setting with Pantron's Win-Connect. This contains:

- extended programming
- diagnostic
- software adaptation and update

Easy adjustment...

1. loosen screw



2. adjust fork width



3. tighten screw



4. press reset button



...ready for operation

Fork light barrier FSI-... / FSR-...

- Fork width infinitely variable
- Fast and easy startup
- Infrared light **FSI-...** or red light **FSR-...**
- High light immunity
- Mounting side by side without influences
- Automatic / manual power adjustment with dirt compensation
- Teach function
- Light / dark function, selectable
- Switching output PNP / NPN or push-pull, selectable
- Pulse stretching
- Protection class IP 67
- Metal housing



Device description

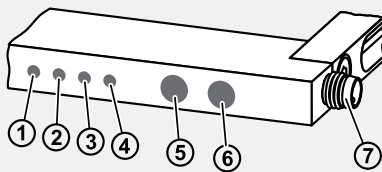

- ① Output status display (OUT)
- ② Signal intensity display (SIGNAL)
- ③ Alarm display (ALARM)
- ④ Power display (ON)
- ⑤ PROGRAM button (PROG [-])
- ⑥ RESET button (RESET [+])
- ⑦ Connection (plug M8, 3-pole)

Technical Data (at 20 °C, 24 V DC)

Operating voltage	12 V DC ... 30 V DC
Current consumption	20 mA
Transmit light	FSI-... infrared (890nm) FSR-... red (650 nm)
Output	PNP / NPN / push-pull
Load	max. 200 mA
Voltage drop	1.3 V
Resolution (smallest detectable part)	1.0 mm
Reproducibility	0.1 mm
Switching frequency	4 kHz / 10 kHz
Pulse stretching	0 / 1 / 10 / 100 ms
Ambient light immunity	60.000 LUX
Ambient temperature	-10 °C ... 60 °C
Protection class	IP 67
Housing material	aluminium anodized black
Connection	plug M8, 3-pole
Dimensions	see picture 1-4 on page 76

Purchase order table FSI-... (infrared)

Fork width	5 ... 85 mm		5 ... 145 mm	
Fork depth	60 mm	90 mm	60 mm	90 mm
Switching frequency 4 kHz	FSI-085V060-B3	FSI-085V090-B3	FSI-145V060-B3	FSI-145V090-B3
Switching frequency 10 kHz	FSI-085V060-S-B3	FSI-085V090-S-B3	FSI-145V060-S-B3	FSI-145V090-S-B3

Purchase order table FSR-... (red)

Fork width	5 ... 85 mm		5 ... 145 mm	
Fork depth	60 mm	90 mm	60 mm	90 mm
Switching frequency 4 kHz	FSR-085V060-B3	FSR-085V090-B3	FSR-145V060-B3	FSR-145V090-B3
Switching frequency 10 kHz	FSR-085V060-S-B3	FSR-085V090-S-B3	FSR-145V060-S-B3	FSR-145V090-S-B3

Accessories

Accessories	page
Interfacebox IFB-1	83
Connection cable CAB-M...	84
PC software WinConnect	85

Connection diagram

M8

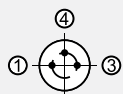

Operating voltage	(+UB)	PIN 1
Ground	(0V)	PIN 3
Output	(S)	PIN 4

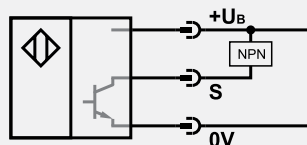

NPN output

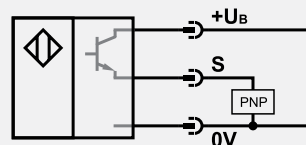

PNP output

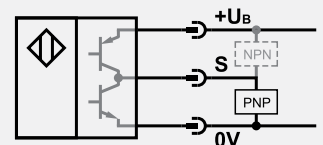

NPN / PNP output (push-pull)

Accessories



Overview

Protective enclosure PanBox	S. 78
Power supply unit PSU-1000	S. 80
Power supply unit PSU-1200	S. 81
1-channel measurement amplifier ISG-N124M	S. 82
Interfacebox IFB-1	S. 83
Communication cable CAB-COM... ..	S. 84
Connection cable CAB-M... ..	S. 84
Measurement cable CAB-TEST... ..	S. 84
Glass fiber optic cable FOI-... ..	S. 84
11-pole DIN-socket ISO 1	S. 85
Retaining clip RTC 11	S. 85
Protective glass shield / light shutter IR... ..	S. 85
Sensor mounting bracket ISH... / KB12	S. 85
Cleaning air nozzle ISO12	S. 85



Protective enclosure PanBox

- Impact resistant polycarbonate
- Transparent top cover
- Protection class IP66
- Cable gland M12 and M16

Technical Data (at 20 °C)

Housing material	
Cover	Glass fiber reinforced polycarbonate
Top cover	Polycarbonate
Ingress protection (EN 60529)	IP 66
Impact resistance (EN 50102)	IK 08
Colour	
Cover	Grey
Top cover	Smokey
Gasket	Polyurethane
Ambient temperature	-40 °C ... +120 °C
Permanent temperature	-40 °C ... +80 °C

For more detailed information see www.pantron.com

Purchase order table

Description	Order code
for one 1-channel amplifier	PanBox 1x1
for three 1-channel amplifier	PanBox 3x1
for one 2-channel amplifier	PanBox 1x2
for one 4-channel amplifier	PanBox 1x4
for one 8-channel amplifier	PanBox 1x8

Protective enclosure PanBox 1x1

for one 1-channel amplifier

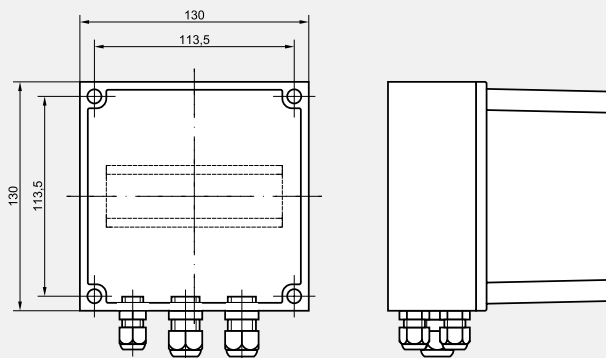
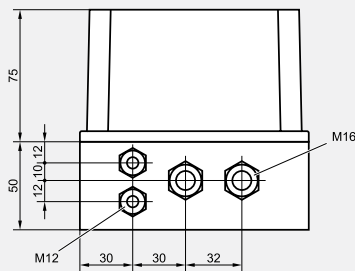

Protective enclosure PanBox 1x2

for one 2-channel amplifier

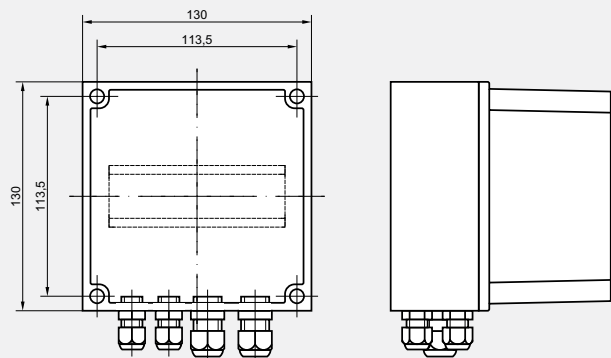
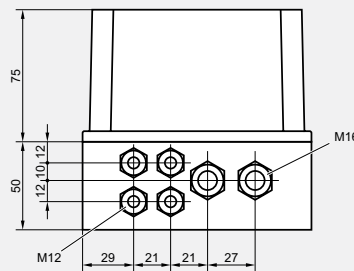

Protective enclosure PanBox 3x1
for three 1-channel amplifier

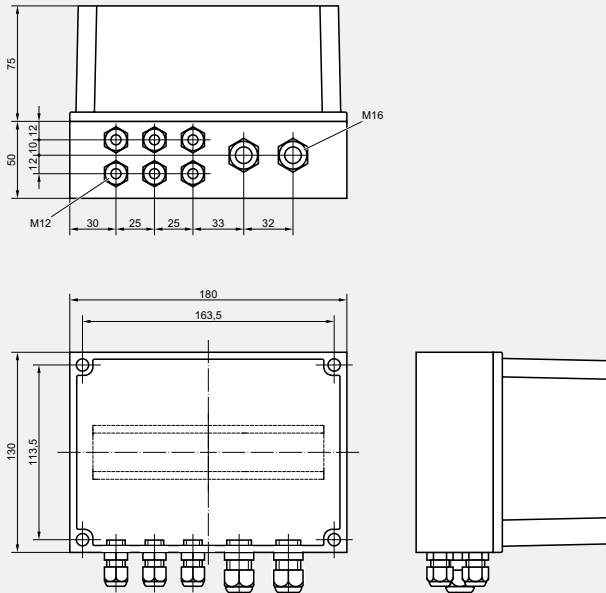

Protective enclosure PanBox 1x4
for one 4-channel amplifier

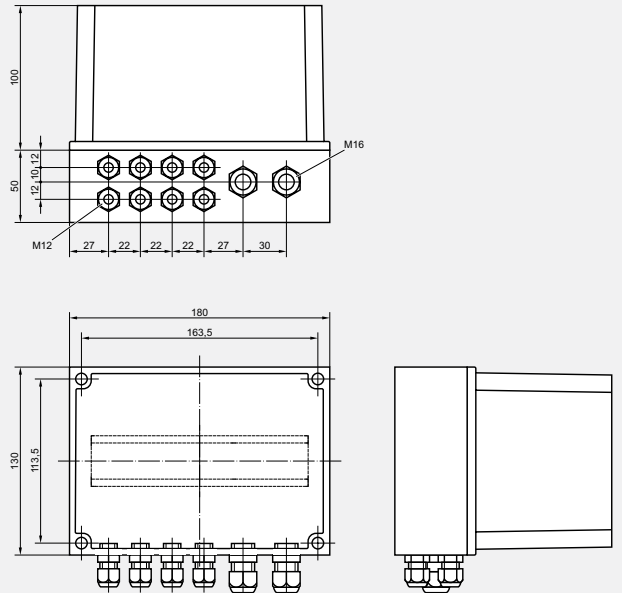

Protective enclosure PanBox 1x8
for one 8-channel amplifier

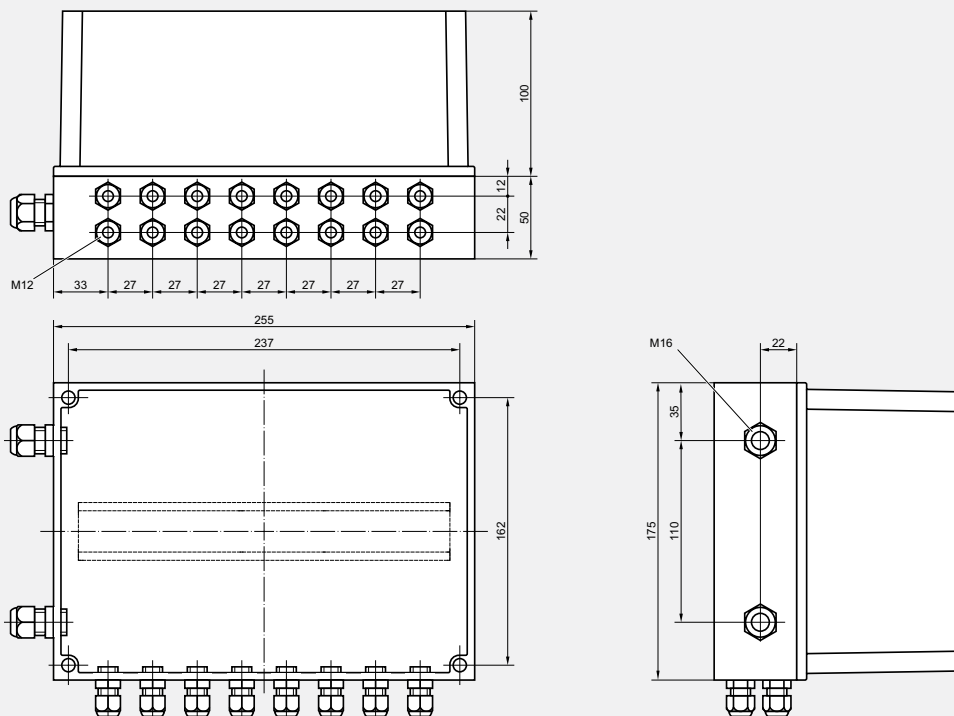



Power supply unit PSU-1000

- Wide input voltage range 95 ... 265 V AC / 47 ... 63 Hz
- Output voltage 24 V DC
- Output power 8.4 W
- Overload protection, short circuit proof
- Overtemperature protection
- External fuse is not necessary
- High Efficiency >74 %
- Switching on current limiter
- Mounting for DIN rail (EN 60715)

Technical data (at 20°C)

Operating voltage	95 ... 265 V AC
Power consumption	max. 8.5 VA
Output voltage	24 V DC, short circuit proof
Voltage tolerance	± 5%
Output load	400 mA
Housing material	NORYL, grey
Protection class (EN 60529)	IP 20
Connection	Screw terminals
Operating temperature	-25 °C ... 50 °C
Dimensions (W x H x D)	35.5 x 90 x 58.5 mm see picture 4 on page 55

Purchase order table

Connection	Order code
Screw terminals	PSU-1000S/95...265VAC

Accessories	Order code	Seite
Protective enclosure	PanBox 1x1	78

Device description

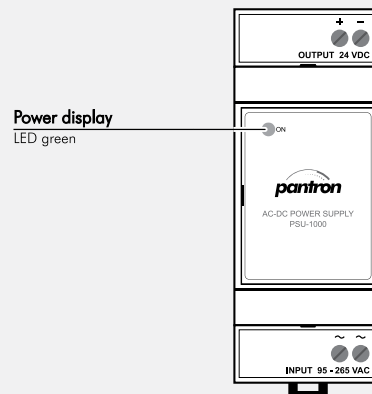

For more detailed information see www.pantron.com

Connection diagram

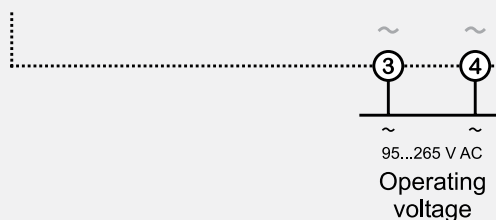

Power supply unit PSU-1200

- Wide input voltage range 95 ... 265 V AC / 47 ... 63 Hz
- Output voltage 15 / 24 V DC
- Output power 10.0 W
- Overload protection, short circuit proof
- Overtemperature protection
- External fuse is not necessary
- High efficiency >74 %
- Switching on current limiter
- Relay output, change over, control with sensor input
- Switching delay for relay output
- Mounting for DIN rail (EN 60715)



Purchase order table

Connection	Order code
Screw terminals	PSU-1200S/95...265VAC

Accessories	Order code	Seite
Protective enclosure	PanBox 1x1	78

Device description

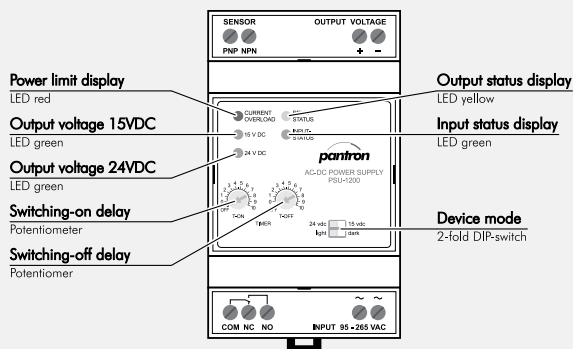

Device mode (factory setting is marked in white)

	1	Output voltage	15 V DC	24 V DC
1	<input type="checkbox"/>		<input checked="" type="checkbox"/>	<input type="checkbox"/>
2	<input type="checkbox"/>	Switching behaviour	light	dark
			<input checked="" type="checkbox"/>	<input type="checkbox"/>

Technical data (at 20°C)

Operating voltage	95 ... 265 V AC	
Power consumption	max. 15 VA	
Output voltage	15 V DC / 24 V DC, short circuit proof	
Voltage tolerance	± 5%	
Load (max.)	15 V DC	650 mA
	24 V DC	400 mA
Switching behaviour	light / dark	
Switching delay	0 ... 10 s	
Parallel connection	yes	
Series connection	yes	
Input	NPN / PNP	
switching level NPN	20 % of the output voltage	
switching level PNP	80 % of the output voltage	
Relay output	1 change over	
Operation values (max.)	5 A / 230 V AC (24 V DC)	
Reaction time	8 ms	
Housing material	NORYL, grey	
Protection class (EN 60529)	IP 20	
Connection	Screw terminals	
Operating temperature	-25 °C ... 50 °C	
Dimensions (W x H x D)	52.8 x 90 x 58.5 mm see picture 6 on page 55	

For more detailed information see www.pantron.com

Connection diagram

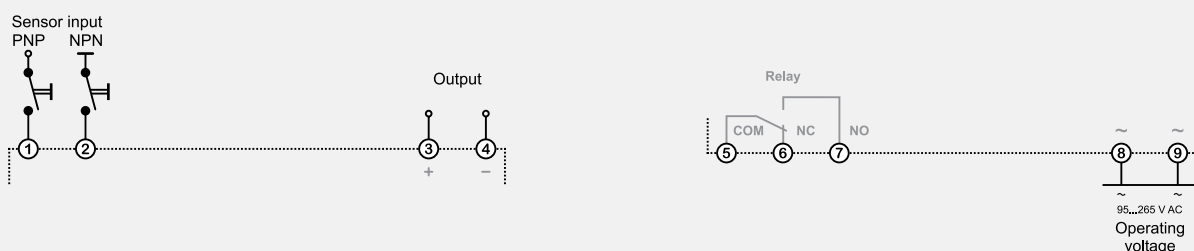



1-channel measurement amplifier ISG-N124M

- Sensor adjustment via analog output
- Detection range up to 55 m
- Sensitivity adjustable with potentiometer
- Sensor control
- Basic transmit level 2-fold selectable
- Switching behaviour light / dark selectable
- Analog output voltage 0-10V / 10-0V selectable
- Transmit frequency 2-fold selectable
- Relay output, change over
- Transistor output, PNP / NPN
- Test input for system check

Technical data (at 20°C)

Operating voltage	see purchase order table
Operating basis	modulated infrared light
Transmit frequency	3.5 kHz / 4.4 kHz
Transmit power	manual
Basic transmit level	low / high
Switching behaviour	light / dark
Switching delay	—
Switching output relay	change over
Operation values (max.)	5 A / 230 V AC (24 V DC)
Reaction time	36 ms
Switching output transistor	NPN / PNP
Operation values (max.) ...AC ...DC	NPN: 100 mA / 30 V DC PNP: 5 mA / 12 V DC 100 mA / 30 V DC
Reaction time	36 ms
Alarm output	—
Test input	24 V DC
Analog output	0 ... 10 V DC
COM-Interface	—
Housing material	plastic
Protection class (EN 60529)	IP 40
Connection	11-pin DIN-plug
Operating temperature	-25 °C ... 50 °C
Dimensions (W x H x D)	40 x 76.5 x 80 mm see picture 10 on page 55

For more detailed information see www.pantron.com

Maximum Range (through beam)

	Receiver IRL-...	Receiver IR-...
Transmitter IT-..., ITL-...	10 m	25 m
Transmitter IT-...HP, ITH-...	15 m	35 m
Transmitter ITA-...	35 m	55 m

Connection diagram

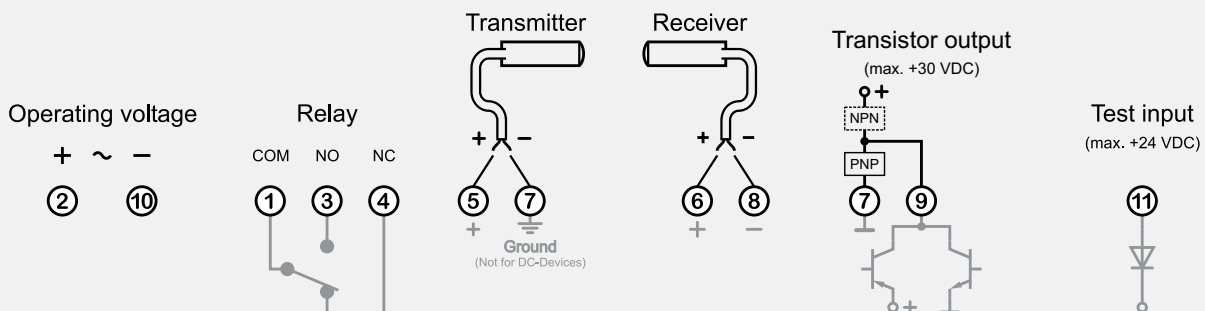

Purchase order table

Operating voltage	Order code
230V AC / ± 10% / 4.2 VA	ISG-N124M/230VAC
115V AC / ± 10% / 4.2 VA	ISG-N124M/115VAC
24V AC / ± 10% / 4.2 VA	ISG-N124M/24VAC
24V DC / ± 20% / 2.0 W	ISG-N124M/24VDC

Accessories	Order code	Page
Protective enclosure	PanBox 1x1	78
Measurement cable	CAB-TEST-4	84
11-pole DIN-socket	ISO1	85
Retaining clip	RTC 11	85

Device description

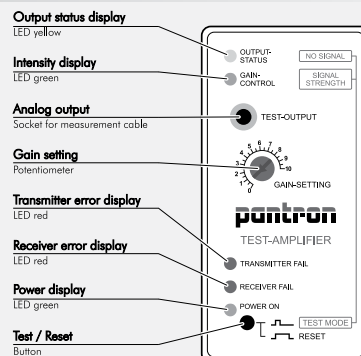

Device mode (factory setting is marked in white)

ON 1 2 3 4	Basic transmit level	Switching behaviour	Analog output	Transmit frequency
	1	2	3	4
low	ON	dark	ON	3.5 kHz
high	OFF	light	OFF	4.4 kHz

Interfacebox IFB-1

- Converter USB - RS232 with galvanic separation
- Isolation voltage 500V
- USB interface adaptor for communication of a PC with Pantron fork light barriers FS... or light barrier amplifiers ISM-4000/8000 (PC-software necessary, see page 85)
- Data transmit and receive display



Purchase order table

Description	Order code	
Interfacebox	IFB-1	
Accessories		
Communication cable	CAB-COM-2	84

Device description

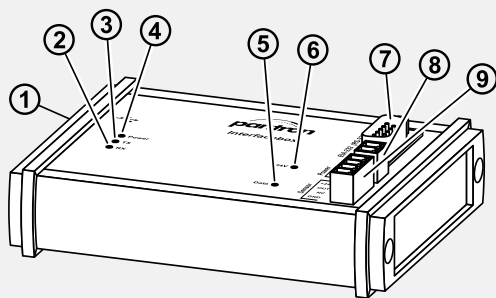

- ① USB connection
- ② Data receive display (RX)
- ③ Data transmit display (TX)
- ④ Power display (Power)
- ⑤ Communication display (Data)
- ⑥ External voltage display (+24V)
- ⑦ RS232 connection (EIA 232)
- ⑧ External supply voltage connection (Power)
- ⑨ Sensor connection (Sensor)

Technical Data (at 20 °C)

USB connector	typ B
current consumption	max. 100 mA
External supply voltage	2-pole screw terminal
input voltage	21.6 V DC ... 26.4 V DC
current consumption	200 mA
Wire size	0.14 ... 2.5 mm ²
Sensor connector	4-pole screw terminal
Wire size	0.14 ... 2.5 mm ²
Housing material	aluminium anodized
Protection class	IP 10
Operating temperature	-10 °C ... 60 °C
Storage temperature	-25 °C ... 80 °C
Dimensions (W x H x D)	115 x 85.6 x 32 mm (without plug) see picture 1 on page 84

For more detailed information see www.pantron.com

Dimensions (in mm)

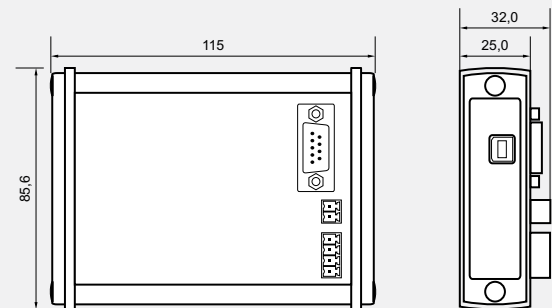

Connection diagram

Communication with fork light barrier FS...

	Connection	Sign	Description
Power	+24V		Supply voltage +
	GND		Supply voltage 0V

	Connection	Sign	Description
Sensor	+24V		Supply voltage +
	OUT		Switching output
	NC		Not connected
	GND		Supply voltage 0V

Interfacebox to connect by a USB cable with a PC
(USB cable included in the scope of supply)

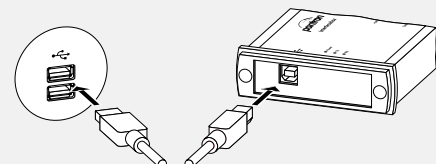

Communication with light barrier amplifier ISM-4000/8000
(Communication cable necessary - not included in the scope of supply)

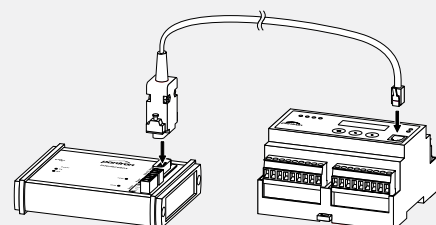

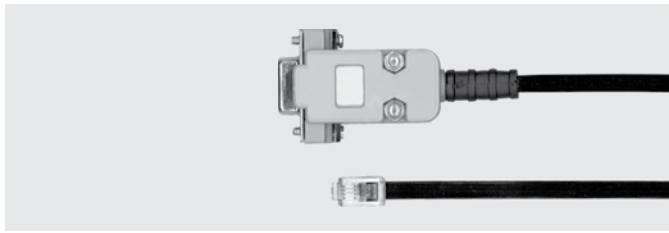

Communication cable CAB-COM...

Purchase order table	
Description	Order code
connection cable for programming the amplifiers ISM-4... / ISM-8... / ICL... via Computer, length 2 m	CAB-COM-2
Other cable lengths by request	



Connection cable CAB-M...

Purchase order table - Plug connector M8 with open ended wires, 3-pole	
Description	Order code
female straight, PVC, length 3 m	CAB-M8-S3-3
female straight, PVC, length 5 m	CAB-M8-S3-5
female straight, PUR, length 3 m	CAB-M8-S3-P3
female straight, PUR, length 5 m	CAB-M8-S3-P5
female right angle, PVC, length 3 m	CAB-M8-R3-3
female right angle, PVC, length 5 m	CAB-M8-R3-5
female right angle, PUR, length 3 m	CAB-M8-R3-P3
female right angle, PUR, length 5 m	CAB-M8-R3-P5

Purchase order table - Plug connector M12 with open ended wires, 3-pole	
Description	Order code
female straight, PVC, length 3 m	CAB-M12-S3-3
female straight, PVC, length 5 m	CAB-M12-S3-5
female straight, PUR, length 3 m	CAB-M12-S3-P3
female straight, PUR, length 5 m	CAB-M12-S3-P5
female right angle, PVC, length 3 m	CAB-M12-R3-3
female right angle, PVC, length 5 m	CAB-M12-R3-5
female right angle, PUR, length 3 m	CAB-M12-R3-P3
female right angle, PUR, length 5 m	CAB-M12-R3-P5

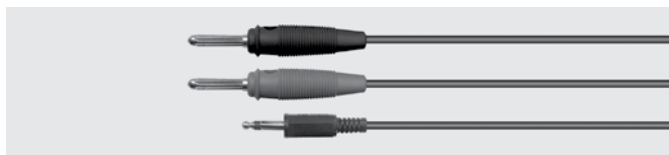

Measurement cable CAB-TEST...

Purchase order table	
Description	Order code
for connecting a measurement unit to the analog output of the measurement amplifier ISG-N124M, length 4 m	CAB-TEST-4

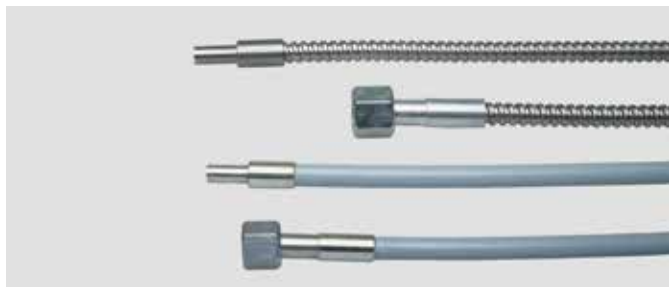

Glass fiber optic cable FOI-...

Purchase order table	
Description	Order code
Cable end Ø6, stainless coating, length 1 m	FOI-40V70-C9/6-1
Cable end Ø6, stainless coating, length 3 m	FOI-40V70-C9/6-3
Cable end Ø6, stainless coating, length 5 m	FOI-40V70-C9/6-5
Cable end Ø6, silicone coating, length 0.35 m	FOI-40S75-C9/6-0.35
Cable end Ø6, silicone coating, length 2 m	FOI-40S75-C9/6-2
Other cable lengths by request / dimensions see picture 1	

Dimension drawing (in mm)

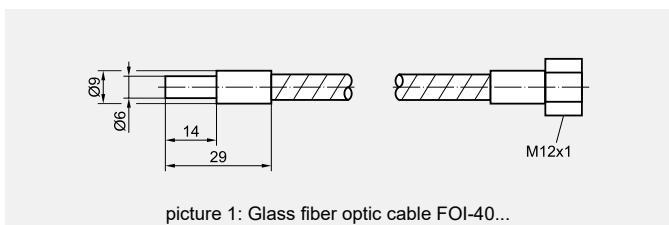

11-pole DIN-socket ISO 1

Purchase order table	
Description	Order code
for connecting and DIN-rail mounting or amplifier with DIN-plug	ISO 1



Retaining clip RTC 11

Purchase order table	
Description	Order code
for a reliable mounting of amplifiers on the DIN-socket by vibrations	RTC 11



Protective glass shield / light shutter IR...

for sensors with M12 thread

Purchase order table	
Description	Order code
Protective glass shield	IR2
Light shutter Ø 1 mm	IR3
Light shutter Ø 1 mm with protective glass shield	IR3G
Light shutter 8x1 mm with protective glass shield	IR4G



Sensor mounting bracket ISH... / KB12

Purchase order table	
Description	Order code
Screw clamp for sensors with Ø 10 mm	ISH1
Mounting clip for sensors with Ø 10 mm	ISH2
Strain relief with 1/2" thread for sensors with Ø 10 mm	ISH10
Screw clamp for sensors with Ø 12 mm	KB12



Cleaning air nozzle ISO12

Purchase order table	
Description	Order code
Attachment with air connection for optic cleaning of sensors with M12 thread	ISO12



PC software

Download the current software version from www.pantron.com	
Description	Code
Configuration software for ISM-series	WinISM
Configuration software for ICL-series	WinICL
Configuration software for ISL-series	WinISL
Configuration software for FSx-series	WinConnect

With the PC software the appropriate devices with a serial interface can easily be programmed. Functions like reading device data, programming of device functions, online overview or diagnostic are provided.



Pantron Instruments GmbH

Süllbergstr. 3-5

31162 Bad Salzdetfurth

Germany

Phone: +49 (0) 5063/9591-0

Fax: +49 (0) 5063/9591-55

sales@pantron.de

www.pantron.com