

Laser Sensor Solutions

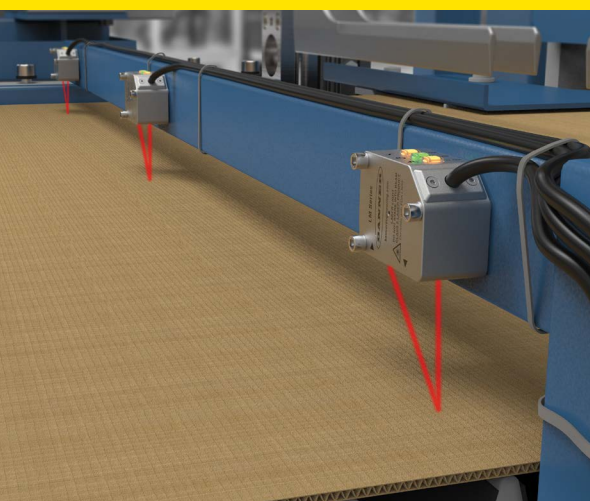

Banner Laser Distance Measurement Sensors

Laser measurement sensors from Banner Engineering are ideal for use in a wide variety of discrete, analog, and IO-Link sensing applications. Our portfolio of laser sensors includes powerful problem-solving, high-precision, and long-range sensors.

Traditionally laser sensors have been used for their extended range, visible beam, small spot, and precise detection capabilities. These benefits have often been outweighed by their higher costs compared with other technologies. In recent years, pricing on components has been reduced and the technology has advanced so that the benefits of laser sensors outweigh the cost differential.

Banner laser measurement sensors have been designed to excel in harsh environments and remove common sensing barriers.

Optimized for the Most Challenging Targets

Automatic Gain Compensation and Highest Excess Gain in Class

Other sensors can be oversaturated and experience increased errors from shiny targets. Banner laser sensors automatically decrease gain to maintain accuracy.

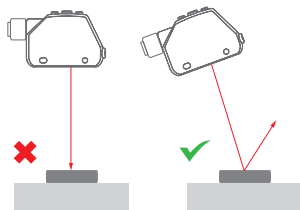
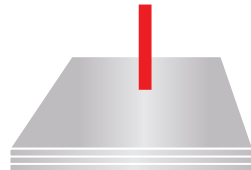

TIP: Change sensor orientation by a few degrees for more reliable detection of shiny objects

Similarly, dark objects provide a very weak signal, so our laser sensors automatically increase gain to amplify the received signal and reliably measure targets that other sensors cannot see.

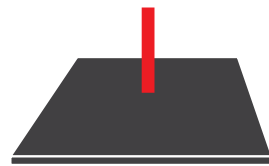

Variety of Beam Spot Sizes for Consistent Detection

A small spot minimizes measurement variation across color transitions



A small beam spot is ideal for precise profiling of small features



A large spot provides averaging across rough surfaces for more measurement stability



Measure from 25 Millimeters to 24 Meters

Triangulation (Short Range/Precise)

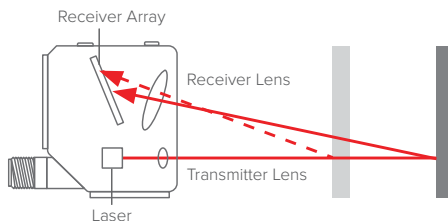

Triangulation sensors determine range by the position of the received light on the receiver array.

Time-of-Flight (Long Range)



Time-of-flight sensors derive range from the time it takes light to travel from the sensor to the target and return.

Best-in-Class Combination of Detection and Range

Minimum Object Separation (MOS)

The minimum distance a target must be from the background to be reliably detected by a sensor. An MOS of 5 mm means the sensor can detect an object that is at least 5 mm from the background.

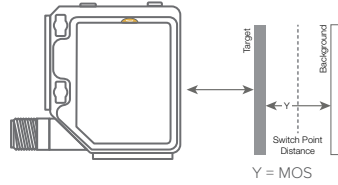

The triangulation sensor and time-of-flight sensor complement each other to solve a wide variety of problems. Triangulation technology is more robust in the near range, while time-of-flight is more consistent across the entire range.

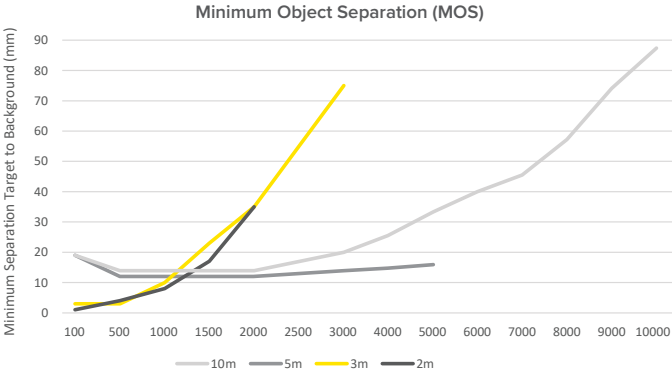

Excess Gain

Excess gain is a measure of the minimum light energy needed for reliable sensor operation. Higher excess gain allows the sensor to detect darker objects at steeper angles.

The Q5X Series has very high excess gain. To detect the darkest targets, the time-of-flight sensor has higher excess gain as users get further away from the sensor compared to the triangulation. Excess gain of 100x means that you can reliably detect an object that only returns 1% of the light reflected off of it. The sensor can easily detect black rubber, foam, or neoprene.

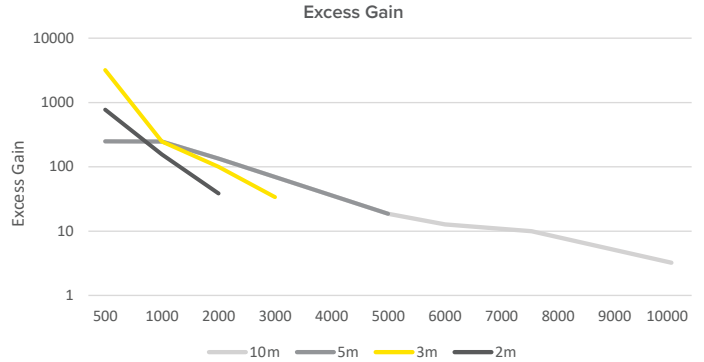

Dual Mode: Distance with Intensity to Detect Any Change

Clear Object Detection

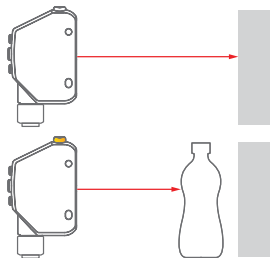

Reliably detect transparent objects without the need of a retro-reflector

Meters of Extended Range

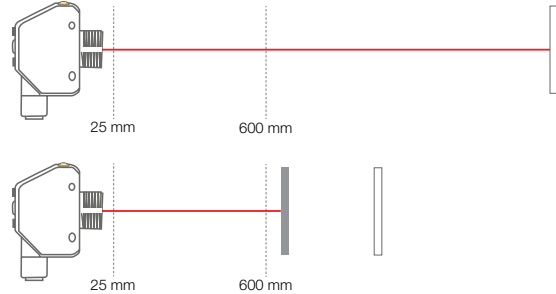

Teach a reference target, even past the maximum measuring range, to detect changes in contrast for presence and absence detection

Error Proofing

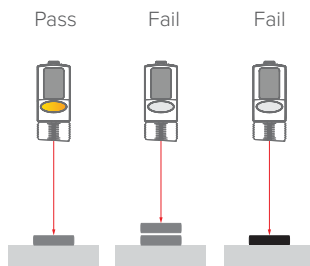

Distance	✓	✗	✓
Color	✓	✓	✗

Inspections use distance to verify parts presence and position, and intensity to verify correct color

Contrast

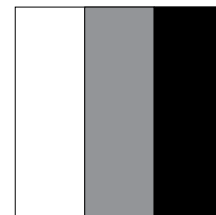

Detects intensity changes due to variation in surface finish, hue, or tone

Choosing a Banner Laser Sensor

Start with
the Q4X



- Versatile problem solver
- Compact size with best-in-class performance
- Robust housing and reliable detection

If the following are needed:

- Longer range
- More excess gain
- Better precision beyond 100 mm



If the following are needed:

- Cost effective laser solution



select Q5X

If the following are needed:

- Better temperature stability
- Higher precision
- Larger display



select Q20-2

If the following are needed:

- Longest range
- Best precision beyond 1 m



select LE

If the following are needed:

- Miniature housing



select LTF

If the following are needed:

- Best performance
- Highest excess gain
- Smallest spot size



select Q2X



select LM

Q4X Applications

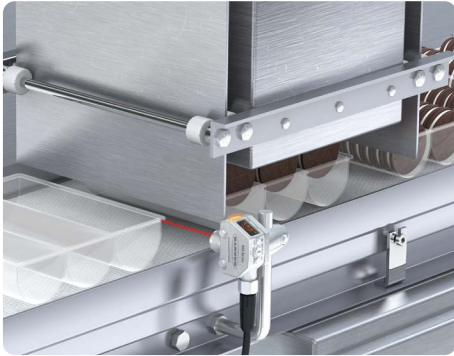

Rugged Environments

- Food and beverage packaging
- Metal stamping
- Robotic welding

Precision Measurements

- Vibratory feeders
- Automotive assembly
- Semiconductor wafer mapping

Low Contrast Sensing

- Plastic bottle jam detection
- Pharmaceutical vial counting
- Vibrant packaging sensing

Q5X Applications



Material Handling

- Jam detection
- Box, tote, and pallet detection

Packaging

- Shrink wrap detection
- Carton full/empty

Lumber and Construction

- Timber, plywood, sheetrock manufacturing
- Steel and asphalt shingle manufacturing

Automotive

- Power train and suspension assembly
- Black plastic/leather/rubber detection
- Dashboards and interior/exterior panels

Q2X Applications



Material Handling

- Box, tote, and pallet detection
- End-of-arm tooling

Level Measurement

- Bin fill
- Hopper fill level

Mobile Robotics

- Positioning
- Package detection

LTF Applications

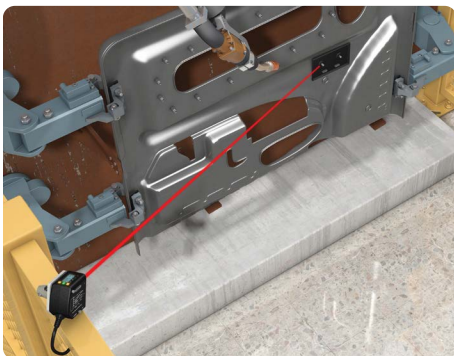

Positioning

- Automated guided vehicle
- Automated warehouse
- Mobile equipment collision avoidance

Measurement

- Hopper fill level
- Port crane height
- Pallet height

Process Control

- Roll diameter
- Loop/tension control
- People counting

LE Applications



Automotive

- Robot positioning
- Assembly inspection
- Tire gauging

Packaging

- Fill level
- Box profiling
- Dancer arm position monitoring

Web Applications

- Loop control
- Roll diameter
- Web thickness gauging

LM Applications

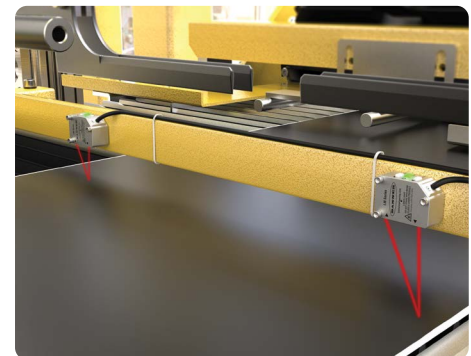

Automotive

- Precise part inspection
- Assembly accuracy checks
- Dimensional control







Electronics and Semiconductor

- Product position control
- PCB warp inspection

Consumer Packaged Goods

- Correct product placement
- Thickness/height measurement

Laser Measurement Sensors Comparison

		Range		I/O Type				User Interface		Repeatability (mm)	Minimum Object Separation (mm)	Resolution (mm)	Linearity (mm)	Principle of Operation		IP Rating
		Minimum Range (mm)	Maximum Range (mm)	Discrete	Analog	Pulse Pro I/O	IO-Link	RSD1 Support	Display					Triangulation	Time of Flight	
	Q4X100	25	100	●	●	●	●	●	± 0.2	0.5–1	0.15	± 0.25–1	●		IP67 IP68 IP69K	
	Q4X300	25	300	●	●	●	●	●	± 0.5–3	1–13.5	0.3–1	± 0.8–9	●		IP67 IP68 IP69K	
	Q4X500	25	500	●	●	●	●	●	± 0.5–6	1–45	0.3–1.75	± 0.8–25	●		IP67 IP68 IP69K	
	Q4X600	25	600	●	●	●	●	●	± 0.5–3	1–10	0.12–3	± 0.75–28	●		IP67 IP68 IP69K	
	Q5X2000	95	2,000	●		●	●	●	± 0.5–10	1–35	–	–	●		IP67	
	Q5X3000	95	3,000	●	●	●	●	●	± 0.5–30	3–75	1–30	± 5–150	●		IP67	
	Q5X5000	50	5,000	●		●	●	●	± 2.0	13–25	–	–	●		IP67	
	Q5X10000	50	10,000	●		●	●	●	± 1–3	13–88	–	–	●		IP67	
	Q20-2	20	3,000	●		●	●		± 15	50	–	–	●		IP65	
	Q2X	20	3,000	●		●	●		± 15	50	–	–	●		IP67	
	LTF12	50	12,000	●	●	●	●	●	± 0.3–2.5	10–13.5	0.9–9	± 10	●		IP67	
	LTF24	50	24,000	●	●	●	●	●	± 0.5–3.5	10–25	0.9–12	± 25	●		IP67	
	LE250	100	400	●	●		●	●	± 0.02–0.2	0.5–1	0.02–0.2	± 0.375–0.9	●		IP67	
	LE550	100	1,000	●	●		●	●	± 0.25–1	2–8	0.5–1	± 2–4.5	●		IP67	
	LM80	40	80	●	●		●	●	± 0.001	0.04–0.06	0.002	± 0.02–0.03	●		IP67	
	LM150	50	150	●	●		●	●	± 0.002	0.12–0.14	0.004	± 0.06–0.07	●		IP67	

Key Specifications for Discrete Applications

Repeatability (or reproducibility) refers to how reliably a sensor can repeat the same measurement in the same conditions. Repeatability of 0.5 mm means that multiple measurements of the same target will be within ± 0.5 mm.

This specification is commonly used among sensor manufacturers and can be a useful point of comparison; however, it is a static measurement that may not represent the sensor's performance in real-world applications.

Repeatability specs are based on detecting a single-color target that does not move. The specification does not factor in variability of the target, including speckle or color/reflectivity transitions that can have a significant impact on sensor performance.

Minimum object separation (MOS) refers to the minimum distance a target must be from the background to be reliably detected by a sensor. A minimum object separation of 0.5 mm means that the sensor can detect an object that is at least 0.5 mm away from the background.

Minimum object separation is the most important and valuable specification for discrete applications. This is because MOS captures dynamic repeatability by measuring different points on the same object at the same distance. This gives you a better idea of how the sensor will perform in real world discrete applications with normal target variability.

Key Specifications for Analog Applications

Resolution tells you the smallest change in distance a sensor can detect. A resolution of <0.5 mm means that the sensor can detect changes in distances of 0.5 mm. This spec is the same as best-case static repeatability, but it is expressed as an absolute number instead of \pm .

The challenge with resolution specs is that they represent a sensor's resolution in "best case" conditions, so they don't provide a complete picture of sensor performance in the real world and sometimes overstate sensor performance. In typical applications, resolution is affected by target conditions, distance to the target, sensor response speed, and other external factors. For example, glossy objects, speckle (microscopic changes in target surface), and color transitions are all sources of error for triangulation sensors that can affect resolution.

Linearity refers to how closely a sensor's analog output, plotted against the actual distance, approximates a straight line across the measuring range. When the linearity spec is lower and the sensor is more linear, the measurements across the full range of the sensor are more consistent. Linearity of 0.5 mm means that the greatest variance in measurement across the sensor's range is ± 0.5 mm.

In other words, linearity is the maximum deviation between the interpolated measurement and the actual distance. If a sensor's 4 mA point is set to 100 mm and its 20 mA point is set to 200 mm, we would expect a 12 mA measured value to represent exactly 150 mm, halfway between 100 and 200 mm. In real life, that 12 mA value would actually represent $150 \text{ mm} \pm$ the sensor's linearity spec.

Linearity is the most relevant error spec for many applications that require consistent measurements across the range of the sensor.

Key Specifications for IO-Link Applications

Repeatability, or how reliably the sensor can repeat the same measurement, is a common specification for IO-Link sensors. However, as with discrete applications, repeatability is not the only factor for IO-Link applications.

Accuracy is the difference between the actual and measured values. It would be used in an application when you are looking at the measurement of an unknown distance, without a reference target. It is especially useful when comparing measurements from multiple sensors.

Linearity would be used instead of accuracy if looking at relative changes in measurements from a known reference target. This is similar to teaching the 4 mA and 20 mA points for an analog sensor, where all distance measurements are relative to the taught conditions.

Tip: Use the IOL Filter parameter (available with Banner IO-Link sensors) to average together more measurements for a more repeatable measurement



Q4X Series

Versatile, Rugged Laser Measurement Sensor

- Problem solving sensor for short range sensing applications
- Compact, rugged IP69, Ecolab-certified, stainless-steel housing
- Discrete, analog, and IO-Link models available
- Flush-mount or barrel-mount housing options for versatility in installation
- Dual mode for contrast and clear-object detection without a reflector



Threaded-Barrel Q4XT

Series	Housing Style	Output	Mode	Range	Connector
Q4X	T	B	LAF	300	Q8
	T = 18 mm threaded barrel	B = Bipolar discrete NPN and PNP K = Dual discrete with IO-Link U = 0–10 V analog I = 4–20 mA analog	LAF = Laser adjustable-field	600 = 25–600 mm 500 = 25–500 mm* 300 = 25–300 mm 100 = 25–100 mm	Q8 = Integral QD

*Not available in dual discrete with IO-Link models

Flush-Mount Q4XF

Series	Housing Style	Output	Mode	Range	Connector
Q4X	F	N	LAF	310	Q8
	F = Flush face	N = NPN discrete P = PNP discrete K = Dual discrete with IO-Link U = 0–10 V analog I = 4–20 mA analog	LAF = Laser adjustable-field	610 = 35–610 mm 310 = 35–310 mm 110 = 35–110 mm	Q8 = Integral QD

Distance: Precision Measurement and Detection Regardless of Target

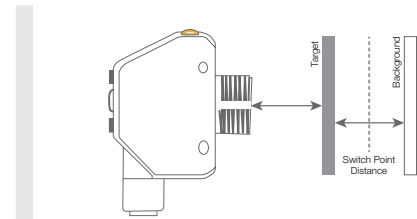
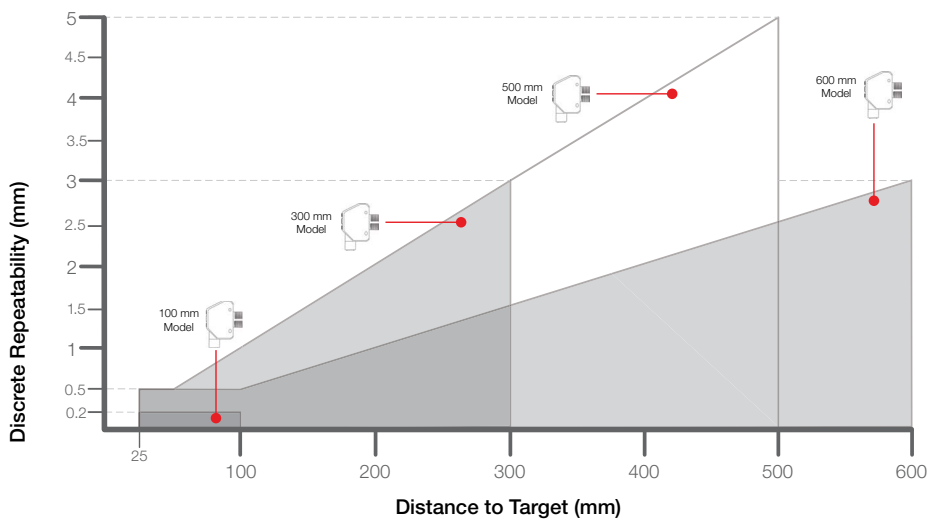

Minimum object detection size for challenging targets (6% reflectivity) at close range.

Q4X...100 / 110	0.5 mm
Q4X...300 / 310	1 mm
Q4X...500	1 mm
Q4X...600 / 610	1 mm



Error Proofing

Challenge

In a car speaker assembly, the presence and placement of all components must be verified to ensure that defective or incomplete products are not shipped to the customer. The small sizes, slim profiles, and similar colors of many components can make identifying errors difficult.

Solution

By measuring the distance from the sensor to the mounting bracket, a Q4X verifies that a single spacer is present and properly seated. Using dual-mode detection, the Q4X can also measure the amount of light received to determine if the spacer has been placed with the adhesive side up or down. The compact size of the Q4X allows for an unobtrusive installation into congested assembly stations.



Clear Object Detection

Challenge

Regulating the flow of bottles on a conveyor can prevent damage to the bottles, product loss, and machine downtime, and it helps to ensure that downstream processes progress smoothly. Variations in bottle shape, size, material, color, and transparency can make detecting bottles and accumulations difficult.

Solution

Taught to recognize a stable background condition, a Q4X operating in dual mode will detect any alteration in the distance to and light intensity from the background condition, making the sensor immune to variations in bottle shape, size, color, clarity, and reflectivity. The Q4X has integral on/off delays that can send a signal if an accumulation occurs.



Q5X

High Power, Multi-Purpose Laser Measurement Sensor

- Versatile sensors for mid-range sensing applications
- Highest excess gain for detecting the darkest targets at extreme angles
- Dual mode for contrast and clear-object detection without a reflector
- Jam-detection model alerts operators to production-line jams, reducing or preventing downtime
- Visible red Class 2 laser with small spot for easy alignment



Series	Output	Emitter	Mode	Range (mm)	Connector	Options
Q5X	K	L	AF	2000	Q8	
	K = Configurable dual discrete with IO-Link on all models KU = 0–10 V with push/pull discrete output or IO-Link KI = 4–20 mA with push/pull discrete output or IO-Link	L = Laser	AF = Adjustable-field background suppression	2000 3000* 5000 10000	Q8 = Integral swivel M12 connector	-Jam = Jam model** Blank = Standard model

*KU and KI models available in 3000 mm range only
**Jam model only available with 2000 mm



Q5Z

High Power, Multi-Purpose Laser Measurement Sensor

- Preconfigured for simple plug-and-play integration
- Teach with simplified single-button interface with feedback from bright indicators
- High excess gain to detect black rubber, shiny metal, and other challenging objects
- Visible red Class 2 laser with small spot for easy alignment



Emitter	Range	Mode	Output	Connector	Model
Laser	1800 mm	Adjustable-field background suppression	Configurable dual discrete with IO-Link	Integral swivel M12	Q5ZKLAF1800-Q8

Note: The Q5Z Global Laser Measurement Sensor is a Class 2 laser sensor with IO-Link and a multifunction output. The single teach button and no display mean the sensor must be configured at the factory. This is so that it is ready for installation out of the box. To customize the configuration for an application, contact Banner Engineering.



Automotive Seat Inspection

Challenge

In automotive quality inspections, verifying the presence of dark parts against an equally dark background is extremely common. For example, many car seats consist of black fabric or leather material with black plastic components, such as levers and buttons to adjust seat height and tilt.

Solution

Banner's Q5X problem-solving triangulation-based laser sensor has no difficulty detecting dark targets on dark backgrounds when there is a height difference. The exceptionally high excess gain enables the Q5X sensor to reliably detect even the darkest objects (<6% reflective black targets), even against a dark background, at all distances from 95 mm to 3 m.

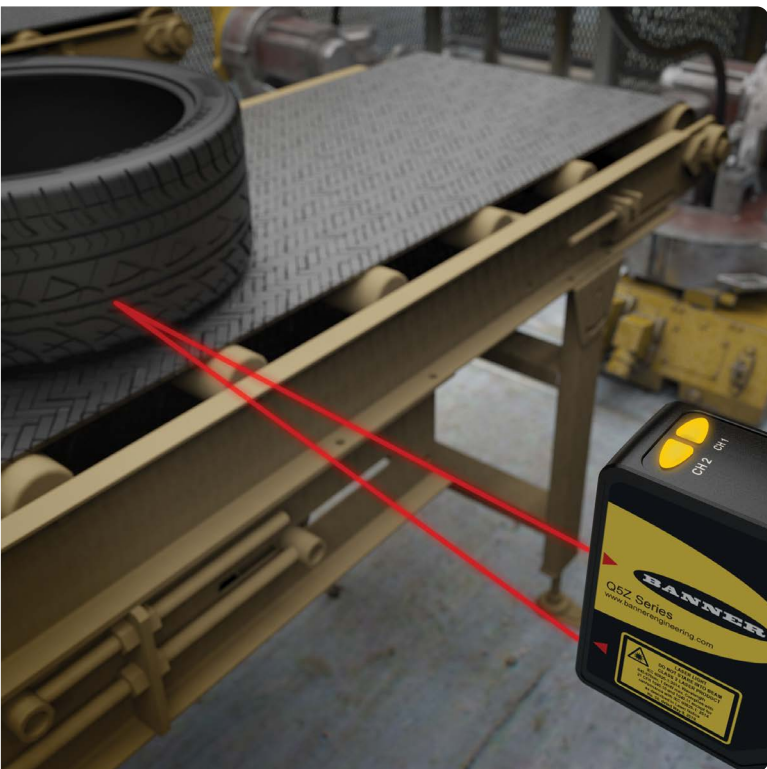

Detecting Dark Tires on Conveyor Belts

Challenge

A tire manufacturer would like to add sensors to the end of a conveyor production line, so that finished tires are accurately stacked on shipping carts. A method is needed to reliably detect dark rubber tires on a dark conveyor belt, so that an automated system can pick them up and place them on the carts.

Solution

The preconfigured Q5Z Global Laser Measurement Sensor with IO-Link can be installed at the end of the conveyor for leading-edge detection of tires as they approach. Q5Z sensors feature high excess gain to detect a wide variety of targets of any shape, color, or reflectivity, and its emitted laser can easily differentiate dark rubber from conveyor belts, without the need for a reflector. Because the sensor can be taught to measure targets at specific set points, it can detect tires at precise distances and ignore other objects on parallel conveyors. With this configuration, the automated process detects the finished tires, picks them up, and places them on carts for shipping, with the correct timing.



LTF Series

Long-Range Laser Measurement Sensor

- Best-in-class combination of range, repeatability, and accuracy for long range sensing applications—out to 24 m
- Highest precision for sensing beyond 1 meter
- Visible red Class 2 laser with small spot for easy alignment, even at long range
- Durable IP67-rated zinc housing stands up to extreme industrial environments
- Two-line, eight-character display for easy setup, troubleshooting, and real-time distance measuring



Series	Range	Output	Laser Class	Sensing Mode	Connector
LTF	12	I	C2	LD	Q
	12 24	I = 4–20 mA analog and (1) NPN/PNP discrete U = 0–10 V analog and (1) NPN/PNP discrete K = Dual discrete (NPN/PNP configurable) with IO-Link	C2 = Class 2	LD = Laser diffuse	Q = Rotatable M12 QD QD models require mating cordset

Best-in-Class Combination of Accuracy, Repeatability, and Range

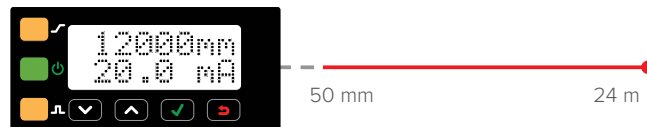
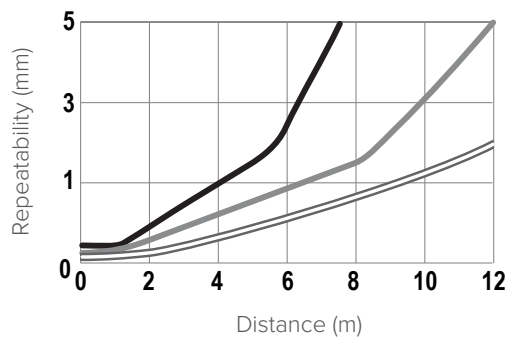

The LTF detects dark targets at 7 meters and white targets at 12 meters with repeatability of <5 millimeters and accuracy from ± 10 millimeters

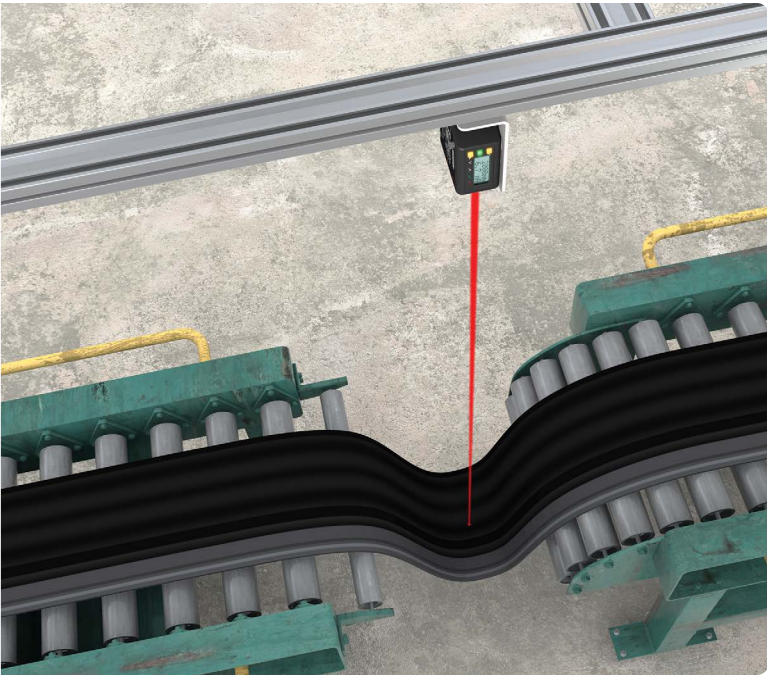

Tension and Speed Measurement on a Calendering Machine

Challenge

To prevent damage to long sheets of material that are processed through calendering machines, and adjust tension and operating speed, the amount of slack must be measured. The dark color and sheen of the rubber makes consistent and accurate detection at a long range difficult for most sensors.

Solution

The LTF takes advantage of high excess gain, superior signal processing, and automatic adaptive laser power control to enable the sensor to reliably detect challenging dark and reflective targets from a distance and at an angle.



Monitoring Levels Inside a High-Volume Hopper

Challenge

Dust and other debris generated during the processing of peanuts can accumulate on the face of a sensor. Gradually this can negatively affect a sensor's performance and may result in unscheduled downtime for maintenance.

Solution

An LTF Series sensor with IO-Link communicates configuration and application trending data via an IO-Link master device to a controller on an industrial network. Monitoring data such as excess gain can help identify debris build-up and assists in preventative maintenance and maximizing machine uptime. If the sensor is ever damaged and requires replacement, configuration data saved on the IO-Link master will automatically update the new sensor.



LE Series

Precision Mid-Range Laser Measurement Sensor

- Highest-precision sensor for mid-range applications from 100 mm to 1 m
- Minimally affected by temperature changes, for measurement stability in any environment
- Two-line, eight-character display for easy setup, troubleshooting, and real-time distance measuring
- Class 1 and Class 2 red laser options for easy alignment



Series	Range	Output	Laser Class	Connector
LE	550	I	Blank	Q
	550 = 100–1000 mm 250 = 100–400 mm	I = 4–20 mA analog and (1) NPN/PNP discrete U = 0–10 V analog and (1) NPN/PNP discrete D = (2) NPN/PNP discrete K = IO-Link and (1) PNP discrete <small>NOTE: Discrete NPN/PNP is user configurable</small>	Blank = Class 2 C1 = Class 1	Q = Rotatable M12 QD <small>QD models require mating cordset</small>

Precision Laser Measurement

LE250

- Measurement range up to 400 millimeters
- Resolution as fine as 0.02 millimeters
- Small laser spot for detecting small features, and best performance across changing colors and reflectivity

LE550

- Measurement range up to 1 meter
- Sub-millimeter resolution across entire range
- Larger spot for better measurement stability across uneven surfaces

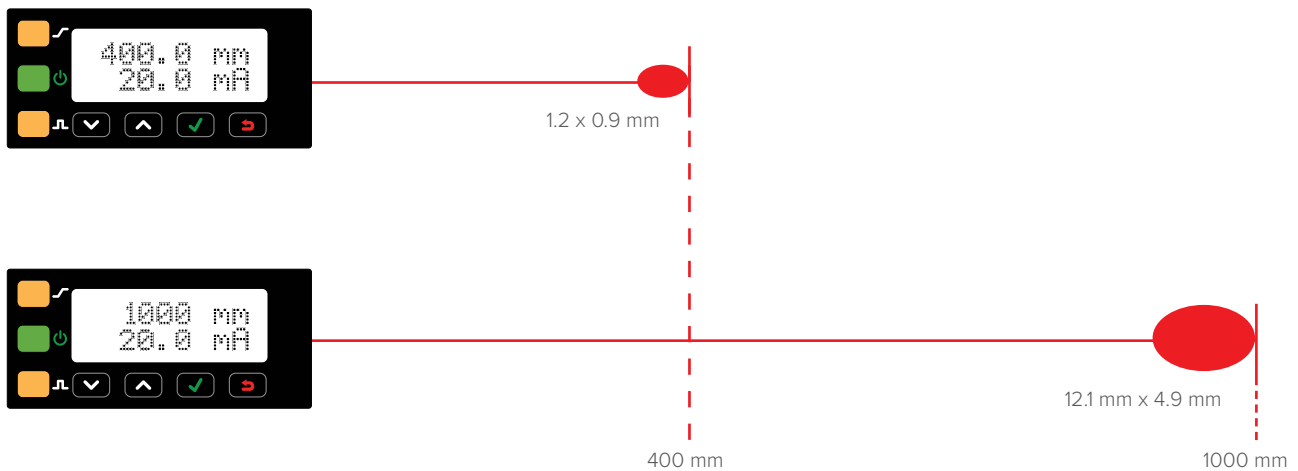

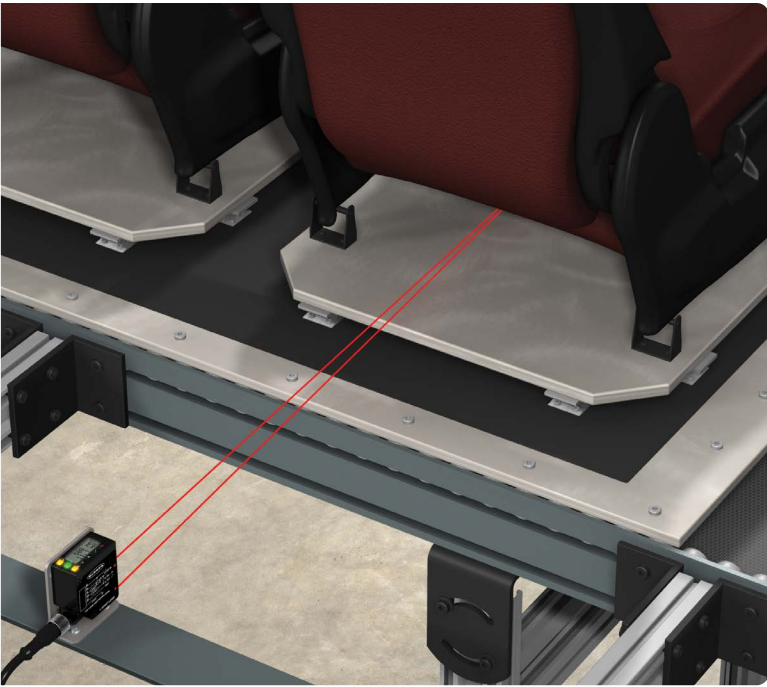

Automated Inspection

Challenge

To work properly, the weight sensor connector on the underside of the seat cushion must be fully inserted. If it is not, airbags will not deploy appropriately in an accident. These systems cannot be used by the vehicle manufacturer and will be returned. The difference between a fully inserted connector and one that is not is a distance of 4 mm. Implementing an automated inspection system would verify that weight sensor connectors were properly installed prior to being shipped.

Solution

Deployed alongside the assembly line, the LE550 targets the back of the weight sensor connector. The visible beam makes it easy to align, and the LCD display greatly simplifies setup. To ensure unimpeded travel on the conveyor, the LE550 is located 500 mm from the target. From this range, it is capable of recognizing changes in distance as slight as 0.5 mm.

As the seat passes by, the LE550 measures the distance between it and the back of the connector. If the connector is measured at a distance less than 500 mm, an alarm notifies the operator and the line is briefly stopped. The operator can then correct the problem while it is easy to access the connector.



Roll Diameter

Challenge

Accurately determining the diameter of a roll of shrink wrap is essential to prevent material from running out during the shrink-wrapping process and ensure proper tensioning. As pallets enter the shrink-wrapping station, a reliable solution must provide accurate data to ensure the shrink wrap tension is what it should be and to alert operators if the roll of plastic wrap is empty.

Solution

Banner's LE550 is factory configured with a range of 100 to 1000 mm and can start measuring immediately. The laser sensor's range can be adjusted easily, either manually or automatically, with an intuitive user interface featuring a two-line, eight-character display. The LE550 provides repeatability and accuracy across challenging targets, from metal to black rubber, which allows for reliable measurement of the shrink wrap.

The analog output can be used to control wind or unwind speeds on the shrink wrap roll. The two-point teach option can be used to set the outside edge of the roll as the 20 mA point and the core diameter as the 4 mA point. This allows easy adjustment without having to unwind the entire roll. The discrete output can also be utilized for a roll diameter application. It can alert operators that the roll is almost empty.

The setup is simple using a single switch point. The user would adjust the feature to set a limit near the diameter of an empty core. No unwinding is needed to complete the discrete output setup.



LM Series

Compact Precision Laser Measurement Sensor

- Short-range, high-precision measurements, even on shiny metals
- High excess gain for detecting the darkest targets
- Minimally affected by temperature changes, for measurement stability in any environment
- Small stainless-steel housing for longevity and durability



Series	Range (mm)	Output	Connector	
LM	150	KI	QP	-X232
	150 = 50–150 80 = 40–80	KI = Discrete with IO-Link and 4–20 mA analog KU = Discrete with IO-Link and 0–10 V analog IRSD = 4–20 mA analog and communications	QP = PVC M12 Pigtail QD	-X232 = RS-232 Serial Communication*



* NOTE: * RS-232 Serial Communication only available with IRSD output and **requires** Communication Cable INT-BBB-X232Q5

Precision Measurement Regardless of Target or Environment

Linearity

Linearity is the maximum deviation between an ideal straight-line measurement and the actual measurement. The more linear a sensor is, the more consistent and precise the sensing results. NOTE: Results shown in the following charts are based on LM150. Better performance will be achieved with the LM80.

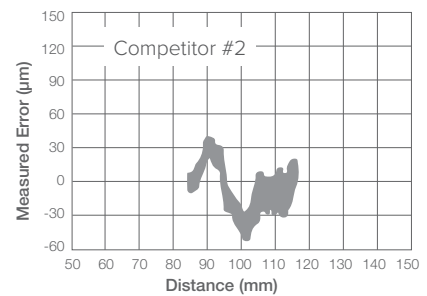
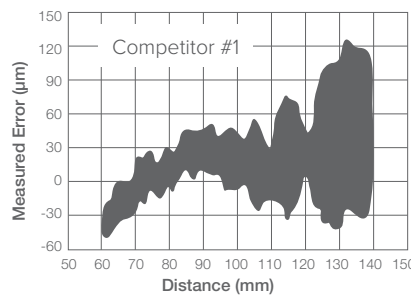
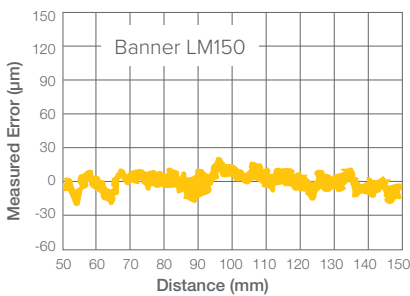

Example linearity on 90% white card

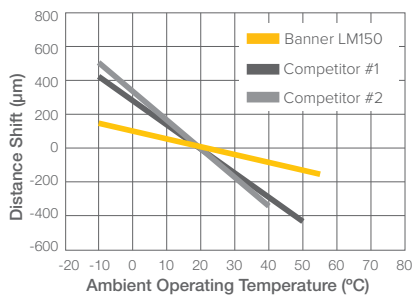

Example temperature effect at max range

Temperature Effect

A sensor with minimal temperature effect is critical for precise sensing applications, since the induced error from just a few degrees of temperature shift can significantly affect the sensors' results.

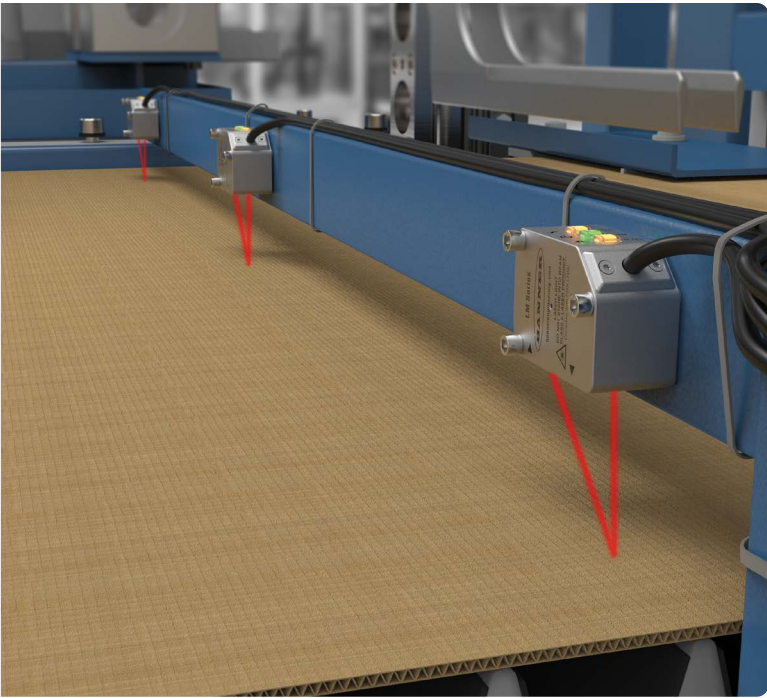

Material Thickness

Many times, product quality is verified at the end of the line. Material that is too thin or too thick must be scrapped. When running long rolls of cardboard sheeting, it is preferable to continuously monitor the thickness, preventing large quantities of product from being out of specification and reducing scrapped material.

Challenge

Cardboard material is run in wide sheets, and the thickness can vary from side to side as well as along the entire length. The temperature in a factory can fluctuate several degrees throughout the day, introducing measurement errors with most sensors.

Solution

Three LM150s placed across the span of material monitor real-time changes in material thickness. The 0.004 mm resolution can detect very small changes in thickness and signal a PLC to speed up or slow down the process, reducing waste. The LM150's stainless-steel design makes it more stable across temperature changes in this environment



Crankshaft Runout Measurement

Crankshaft runout is measured to make sure it is within the manufacturer's tolerance. If the crankshaft is out of tolerance, it can lead to mechanical failures and damage to the engine.

Challenge

A crankshaft can be a challenging target for any optical sensor, because the shiny metal generates specular reflections while oil residue can present a much darker target. In production environments, crankshafts are often rotated quickly to minimize the time spent on inspection and increase throughput.

Solution

The LM has dynamic power adjustment for precision measurement across shiny and dark targets, providing less measurement variation and enabling more reliable inspections. The LM is capable of a 4 kHz measurement rate, a best in class measuring speed, for more precise tracking of geometry changes and more robust inspections. The accuracy of the LM sensor can assure parts meet tight tolerances with fewer missed defects and false failures.



Q20-2

Compact Laser Measurement Sensor

- Infrared laser sensor's range uses time-of-flight technology to consistently and reliably detect targets up to 3 meters away
- Multiple sensing modes solve many different application problems, reducing stock by using just one sensor
- Visible red alignment LED expedites and simplifies setup, and can be switched on or off
- Industry standard 25.4 mm mounting hole spacing on the compact housing makes mounting easy, both on new builds and by using existing mounting holes when retrofitting equipment
- IO-Link® streamlines control system integration and provides easy access to measurement values, delay timers, and advanced diagnostics
- PulsePro output allows direct integration with Banner Pro lighting for real-time visual feedback without a PLC

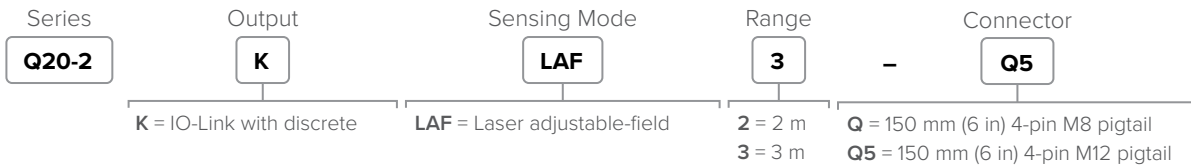

Q2X

Miniature Laser Measurement Sensor

- Measure farther with the industry's longest sensing range for a sensor in a miniature housing
- Sense the most challenging targets like dark or shiny poly bags with a powerful infrared laser with best-in-class excess gain
- Employ in many applications with an array of sensing modes, including background suppression, window mode, and dual mode
- Integrate easily into most control systems and access advanced diagnostics via IO-Link
- Provide real-time visual feedback to machine operators without using a PLC by integrating the PulsePro output directly into Banner Pro lights

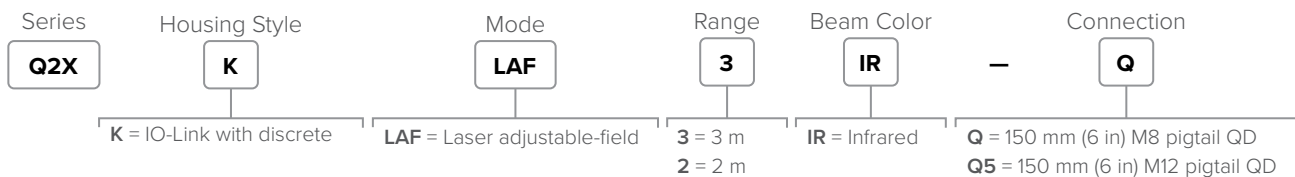

QD models require mating cordset

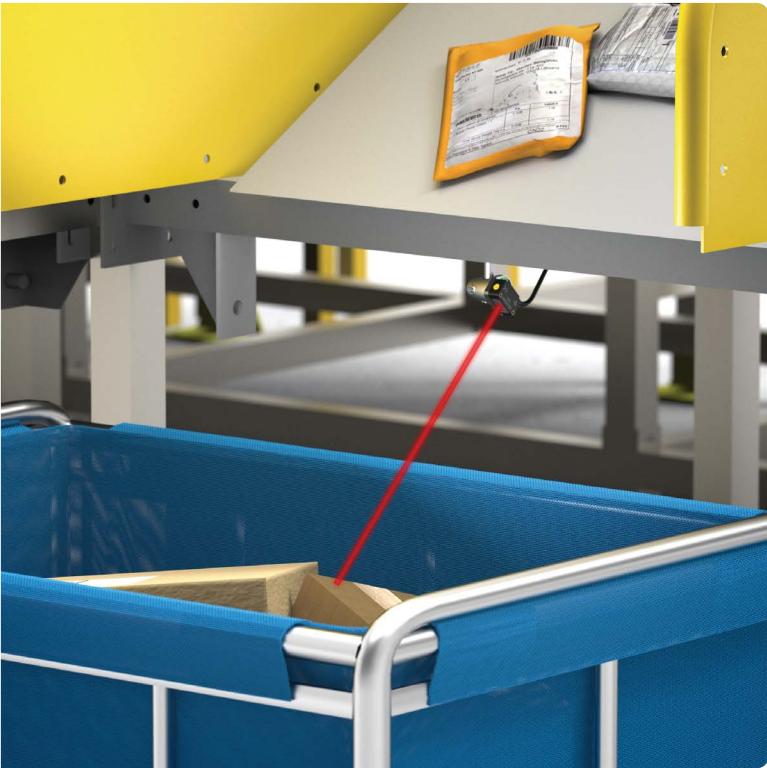

Single-Point Bin Fill Level Measurement

Challenge

Without real-time bin-fill measurement, workers in a distribution center won't know when to most efficiently retrieve bulk containers full of packages distributed by automated sorting systems. This can lead to overfilled bins and possibly lost or misplaced goods if packages land in unexpected places.

Solution

- A Q20-2 Laser Measurement Sensor detects fill height using an infrared laser
- Measures varying types of surfaces, without regard to color, that may be shiny, dark, or clear
- Ideal for monitoring a single point, it delivers high performance at a lower cost than 3D time-of-flight options
- Visible red LED alignment aid for easy setup and installation



Jam Detection on Sorter Chutes

Challenge

Within warehouses, retroreflective sensors are often used to detect blocked chutes before they can disrupt throughput. However, a single package stuck blocking a beam can cause a false jam and shut down equipment.

Solution

- A Q2X Laser Measurement Sensor with adjustable background suppression detects jams accurately and reliably
- A cutoff distance taught slightly away from the back wall ignores temporarily stuck packages without halting operations
- Built-in delay timing (available over IO-Link) ensures the system waits to confirm a true jam before shutting down
- Reduces false jam events, resulting in improved throughput and operational efficiency

Smarter Automation. Better Solutions.™

Banner Engineering designs and manufactures industrial automation products including sensors, smart IIoT and industrial wireless technologies, LED lights and indicators, measurement devices, machine safety equipment, as well as barcode scanners and machine vision. These solutions help make many of the things we use every day, from food and medicine to cars and electronics. A high-quality, reliable Banner product is installed somewhere around the world every two seconds. Headquartered in Minneapolis since 1966, Banner is an industry leader with more than 10,000 products, operations on five continents, and a worldwide team of more than 5,500 employees and partners. Our dedication to innovation and personable service makes Banner a trusted source of smart automation technologies to customers around the globe.

