

## Testable surface sensor for moving operation on automatic door systems

### Translation of the original instructions

#### General

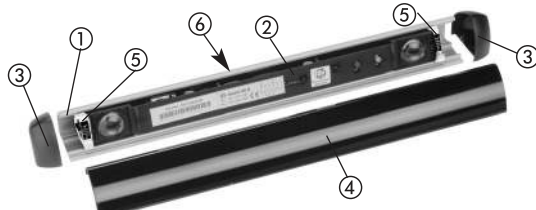

- ① Aluminium profile
- ② Sensor (US beam)
- ③ End cap 2x
- ④ Front cover
- ⑤ Bearing clamp 2x
- ⑥ Screw terminal (not visible in figure)

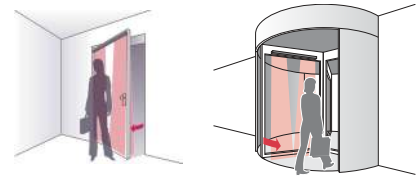

#### 1 Safety instructions



- Read these operating instructions thoroughly before putting the device into operation and keep them for future reference.
- This product is designed to be mounted above an overhead pedestrian door.
- Do not use this product other than for its specified application.
- Only trained and qualified personnel may install and initialize the device.
- Only authorized factory personnel may perform hardware/software changes or repairs to the product.
- Failure to follow these safety precautions may cause damage to sensor or objects, serious personal injury, or death.
- It is the responsibility of the equipment installer to carry out a risk assessment and to install the system, in compliance with applicable local, national and international regulations, safety standards, codes and laws as well as the Machinery Directive 2006/42/EC, should this apply.

- Always consider the safety functions of your applications as a whole, never just in relation to one individual section of the system.
- The sensor should only be operated from a safety extra low voltage (SELV) system with safe electrical separation according to EN 61558. The wiring must be protected against mechanical damage.
- If the front cover ④ breaks, there is a risk it may shatter.
- The sensor may only be operated in the aluminium profile provided for this purpose.
- Parts of the sensor may become hot during operation.
- Avoid touching any electronic and optical components.

#### 2 Start-up

**Recommended start-up sequence:** I. Mounting the aluminium profile, II. Connect, III. Mounting sensor/cables, IV. Adjusting the angle, V. Initialisation

The start-up procedure below covers virtually all applications. However, you may have need of a particular setting not described here. In this case, please refer to your application documents and to the table found in chapter 3 of these instructions; alternatively, you can contact our product specialists.

##### 2.1 Mounting the aluminium profile

I Mounting the profile

1. If the profile ① does not have any mounting holes, make some in the rear of the profile and mount it so that it is horizontal (use a spirit level). Important: The aluminium profile must lay **flat** against the mounting surface.

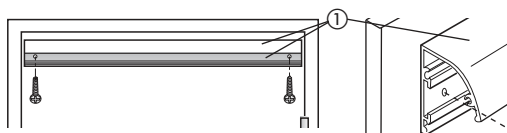

2. If the front cover ④ has been supplied by metre and needs to be cut to size, lay it on a **flat, clean surface** and cut it using a **fine tooth hacksaw, a metal cutter or a rotary tool** (with an appropriate attachment), without applying any pressure. To attach the cover following start-up: 1. remove protective foil 2. Insert the cover ④, 3. Click the cover into place.

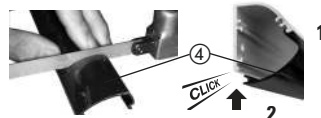

3. Affix the end caps after attaching the cover. Affix the end caps ③ with alignment pins on the profile side. Optional: Affix the end caps with screws for reinforced fixation. Therefore pierce through the drill-hole.

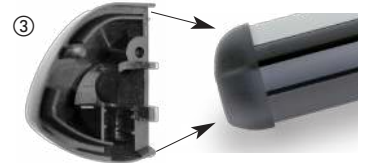

##### 2.2 Electrical connection

II Connect

###### Connection diagram for individual sensors

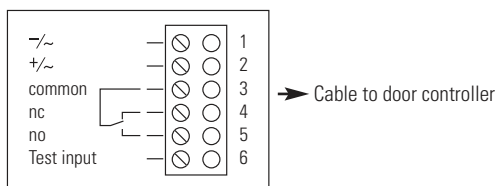

**Attention!** Connection scheme is illustrated powered off  
In standard relay is powered (passive)  
NC = Use connection 5 (NO)

###### Notes on wiring:

###### Wiring according to the requirement of the door system

1. Pull screw terminal ⑥ out of the sensor to be connected to the door controller (= master sensor).
2. Perform wiring in accordance with the door controller specifications.
3. Once the plug terminal has been wired, re-insert it into the sensor.

###### Master/slave wiring

Master/slave wiring using enclosed ribbon cable. A maximum of 3 additional slave modules can be added in this way.

**Attention!** If AC voltage is supplied, only single sensor operation is possible and it is not allowed to cascade the sensors by ribbon cable. Always use ferrules when wiring (recommended core cross-section 0.25 mm<sup>2</sup>).

For a both-sided protection of the door, it is recommended to use the optional Y-Adapter (288879).

##### 2.3 Mounting the optical unit

III Mounting sensor/cables

The buttons red and green on the optical unit must be mounted onto the corresponding door edge.

Sensor ②b must be rotated by 180° and mounted.

Rotate by 180°

To do this, rotate the mounting clips ⑤ on the sensor ② (in the sequence A, B, C, D).

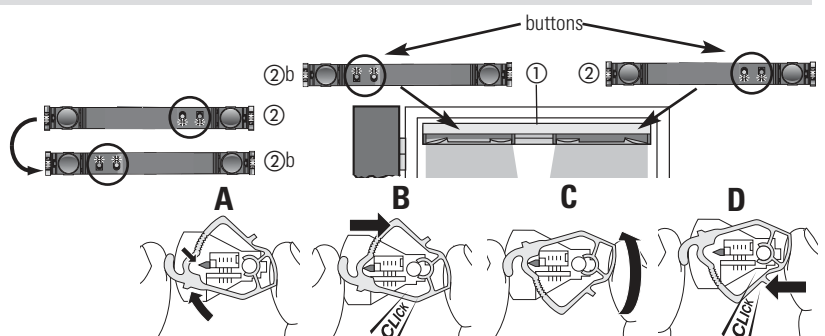

1. Click sensors ② and ②b onto the aluminium profile ①. Insert the upper lug of the mounting clips ⑤ into the upper groove of the profile ①, then click into place.
2. There is space for the cables between the mounting clip ⑤ and the profile ①.
3. Use the ribbon cable ⑧ to connect the individual sensors ② and ②b (note the narrow and wide grooves, do not use force to insert the cable).

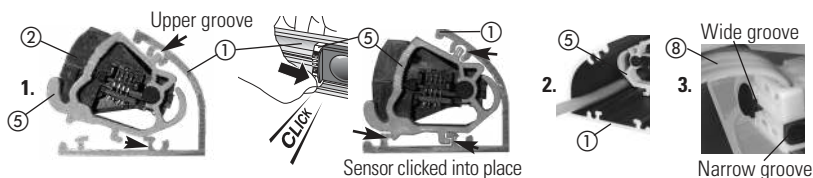

## 2.4 Setting the inclination angle

To ensure correct functioning, **the same angle must be set on the left and right sides of a sensor.**

The position of the detection field ⑩ is determined by the position of the US beam in the aluminium profile.

**Push the sensor as far as possible to the left or right end of the profile in order to protect the closing edges.**

The inclination angle of each sensor must be selected such that the door stops **BEFORE** it comes into contact with an obstacle.

The inclination angle values specified cover 90% of all applications. For special applications, refer to your application documents.

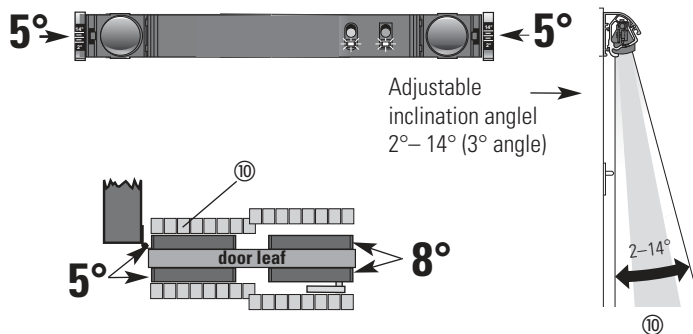

IV Adjusting the angle

## 2.5 Initialisation of a sensor

**A sensor must always be initialised on the master module on each start-up (first initialisation).**

Notes on initialisation for special backgrounds:

In the case of special backgrounds (such as a metal grating), place a cardboard on the background in order to ensure faultless initialisation (see the table in chapter 5 relating to background composition parameters).

### Master-initialisation using the «green» key:

Press the «green» key for **5 seconds** to trigger the master-initialisation procedure. Trigger the master-initialisation only on the sensor which is connected with the door controller.

«green» key «red» key

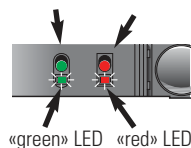

1. Both the red and green LEDs flash to show that the initialisation procedure has been triggered. You now have 6 seconds to leave the detection field.
2. The red LED flashes to show that initialisation is being performed. Do **not** enter the detection field.
3. If the LEDs continue to flash as before, please refer to chapter 4, Troubleshooting.
4. Once both LEDs cease to flash, initialisation is complete.

### Master-initialisation using the remote control (RegloBeam 2):

Initialisation:

1. Press key «G»
2. Press keys **F + 3 + 6** to trigger the initialisation procedure
3. lock the remote control: **F + 3 + 8**



The remote control is available as an optional accessory.

**After initialisation, the sensor is ready for operation. Please check the sensor's detection responses. If they do not meet your requirements, you can use the sensor's keys or the remote control to set various detailed configurations and optimise your door system's functionality (see next chapter).**

V Initialisation

## 3 Setting options for parameters and values

### Example of a sensitivity setting

#### Setting using the «red» and «green» keys:

1. Press the «red» and «green» keys for 1 second, -> device located at parameter 1, «test input».
2. Press the «red» key 3 times -> device moves to parameter 4, «sensitivity» and indicates a value of 3 (20 cm) by flashing green 3 times
3. Press the «green» key twice -> device indicates a value of 5 (40 cm) by flashing green 5 times.
4. Optional: Exit setting mode by pressing the «red» and «green» keys for 1 second.

#### Notes on setting options:

##### Nature of the background:

- One of 3 setting options must be selected, depending on the composition of the ground being used. If the red LED blinks twice and there is no object in the sensorfield, a special background has to be set:
  - Standard
  - Very dark and/or reflecting ground
  - Metal grating -> A base must be placed over the grating during initialisation (the sensitivity is then fixed at  $\geq 50$  cm). This setting will switch off the background test and -tracking function.

##### Synchronisation:

- Synchronisation is active in standard mode and ensures that the sensors will continue to work faultlessly even if fields overlap.
  - Caution: If a US beam (green label) or a R3 (yellow label) is used together with an older release, synchronisation must be switched off and overlapping prevented manually (various levels, switch off beams).

#### Setting using the remote control:

1. Press key «G» on the remote control («3» lights up for the device with address 3, for example).
2. Press key «D»; key «3» lights up, i.e. the previous value was 3 (20 cm).
3. Press key «5»; a value of 5 (40 cm) is set (key «5» lights up).

Note:

The parameterisation by remote control will be locked after 30 min without operation. Reactivation: briefly press the green key, switch the supply on/off or enter an activation code.

#### Sensitivity:

- The sensitivity value must be selected on-site in accordance with requirements (e.g. DIN 18650, EN 16005).
  - The values specified are guide values and relate to the height of the object to be detected. This will vary depending on the composition of the background and must be checked on-site.

#### Initialisation:

- The mounting height of the sensors is memorised during initialisation.
  - The corresponding specified height is saved in parameter 8 using values 1 – 4 (1 = 1.4 – 1.7 m approx., 2 = 1.7 – 2 m approx., 3 = 2.0 – 2.4 m approx., 4 = 2.4 – 3.0 m approx.).

#### Restoring the factory default setting:

- **Press both the «red» and «green» keys for 5 seconds until the red LED flashes rapidly, then release them.**

#### Enhanced levels

Standard mode sets all values to their factory default settings and switches all light beams on. Power saving mode sets all values to their factory default settings and switches light beams 2, 4 and 6 off.

## Setting options using keys & remote control:

**Note: If parameters are changed, an initialisation procedure must always be performed on the corresponding sensor module.**

	Value 1:	Value 2:	Value 3:	Value 4:	Value 5:	Value 6:	Value 7:	Value 8:	Value 9:	Notes:
<b>1</b> Test input	Remote control	1	2	3	4	5	6	7	8	9
<b>2</b> Light beams	Sensor keys	flashes 1x	flashes 2x	flashes 3x	flashes 4x	flashes 5x	flashes 6x	flashes 7x	flashes 8x	flashes 9x
<b>3</b> Output	Remotecont.	press 1x	press 1x	press 1x	press 1x	press 1x	press 1x	press 1x	press 1x	press 1x
<b>4</b> Sensitivity	A	High aktive pull up	High aktive pull down	Low aktive pull up	Low aktive pull down	Low aktive pull down	Low aktive pull down	Low aktive pull down	Low aktive pull down	Low aktive pull down
<b>5</b> Relay hold interval	C	Relay active circuit	Relay active circuit	Relay active circuit	Relay active circuit	Relay active circuit	Relay active circuit	Relay active circuit	Relay active circuit	Relay active circuit
<b>6</b> Device address	D	10 cm	15 cm	20 cm	30 cm	50 cm	70 cm	10 s	10 s	10 s
<b>7</b> Nature of the background (ground)	E	0 ms	50 ms	200 ms	500 ms	1 s	3 s	6 s	10 s	10 s
<b>8</b> Initialisation	F + 1	1	2	3	4	5	6	7	8	9
<b>9</b> Synchronisation mode	F + 2	standard	Floor: dark/reflecting	Floor: Metal grating (use a base when making settings)	Mount. height 1.7 - 2 m approx.	Mount. height 2 - 2.4 m approx.	Mount. height 2.4 - 3.0 m approx.	Mount. height 2.4 - 3.0 m approx.	Mount. height 2.4 - 3.0 m approx.	Mount. height 2.4 - 3.0 m approx.
Enhanced levels (via remote control only)	F + 3	Standard mode	Standard mode	Standard mode	Standard mode	Standard mode	Standard mode	Standard mode	Standard mode	Standard mode
	F + 4	Standard mode	Standard mode	Standard mode	Standard mode	Standard mode	Standard mode	Standard mode	Standard mode	Standard mode
	F + 8	Standard mode	Standard mode	Standard mode	Standard mode	Standard mode	Standard mode	Standard mode	Standard mode	Standard mode

**Parameter 2, light points:** The setting options available via the remote control and sensor keys differ for parameter 2. Individual beams can be switched off and on using the remote control, whilst light beam patterns can be set using the «red» and «green» keys. **If light beams are switched on or off, the «light teach-in» function must be executed.** With sensitivity levels 6 and 7, the sensor only has access to 7 light beams; beam 8 is deactivated.

	Value 1:	Value 2:	Value 3:	Value 4:	Value 5:	Value 6:	Value 7:	Value 8:	Value 9:
<b>2</b> Light beams	Remote control	B + Nr.: beam 1	B + 3: beam 3	B + 4: beam 4	B + 5: beam 5	B + 6: beam 6	B + 7: beam 7	B + 8: beam 8	B + 9: all beams on
	Displayed and selected as «on» or «off» using keys 1 and 2	1: on, 2: off	3: on, 4: off	5: on, 6: off	7: on, 8: off	9: on, 0: off	1: on, 2: off	3: on, 4: off	5: on, 6: off, 7: on, 8: off, 9: on
	Sensor keys	flashes 1x	flashes 3x	flashes 4x	flashes 5x	flashes 6x	flashes 7x	flashes 8x	flashes 9x
	After parameter 1, press 1x	1-2-3-4-5-6-7-8	3-4-5-6-7-8	4-5-6-7-8	1-2-3-4-5-6-7	1-2-3-4-5-6-7	1-2-3-4-5-6-7	2-3-4-5-6-7	1-2-3-4-5-6-7-8
	flashes 2x	1-2-3-4-5-6-7-8	3-4-5-6-7-8	4-5-6-7-8	1-2-3-4-5-6-7	1-2-3-4-5-6-7	1-2-3-4-5-6-7	2-3-4-5-6-7	1-2-3-4-5-6-7-8

Parameter 2 using the «red» and «green» keys

○ = Fulfills DIN 18650 installed moving ○ Factory default setting \* As-delivered condition

## 4 Troubleshooting

Symptom	Possible cause	Remedy
The red LED flashes 8 times after initialisation	- The detection field was not empty during initialisation - The bearing clamps are not mounted correctly in the profile - The bearing clamps are set to different angles on the same sensor - Reflecting background or metal grating	- Carry out the initialisation again - Click the bearing clamps into the profile correctly - Set the bearing clamps to the same angle - Select a different background
The red LED flashes continuously	- Faulty ribbon cable	- Replace the ribbon cable
The red LED flashes twice	- Dark or reflecting ground - Object in the detection field (no fault)	- Set parameter 7 to «dark / reflecting»
The door does not open or close although nothing has been detected	- The test input has not been activated or an incorrect version has been activated	- Make sure that the test input has been activated - Set the correct relay output in accordance with the door controller (see page 3, test input)
Master initialisation does not work, the red LED flashes 4 times	- Use of AC voltage	- Convert the sensors to a DC supply
Not all sensors react when carrying out the master initialisation	- Use of AC voltage - Connection interrupted along the ribbon cable	- Convert the sensors to a DC supply - Insert the ribbon cable correctly or replace it
No reaction from the doors, although detection is taking place	- Initialisation has been carried out on a sensor that is not directly connected to the door controller or to the Y adapter	- Carry out initialisation on the sensor that is directly connected to the door controller
The sensor functions without the cover but not with it	- The angle of the bearing clamps has changed - The cover is of poor quality (has coarse grooves) - Sensitivity too low	- Check the angle of the bearing clamps - Replace the cover - Increase the sensitivity
The red LED flashes 4, 5, 6 or 7 times	- Use of AC voltage - Configuration error (sensors have been swapped following master initialisation) - Sensors have been incorrectly initialised or not initialised at all - Self-test failed, triggered unexpectedly	- Convert the sensors to a DC supply - Carry out the initialisation again - Carry out initialisation on the master (sensor on the door controller) - Carry out the initialisation again
Both LEDs (red and green) are lit permanently	- Supply voltage is not stable enough - Supply voltage is too low - Voltage break	- Isolate the sensor from the supply - Check the power supply - Switch the supply on again
Detection sometimes takes place whilst the door panels are moving	- If the floor is very uneven and the door moves, this may lead to detection - Incorrect background parameters have been selected	- Reduce the sensitivity - Select the correct background parameters - Set a different angle (ensure safety requirements are met)
Incomprehensible response to a cascade of several devices, red LED flashes once	- Various sensor releases have been used (release 2, release 3 and US beam sensors)	- Only use US beam and/or release 3 sensors - For US beam or release 3 sensors, switch synchronisation off and manually prevent any overlap
The red LED flashes 10 times	- Loss of power during parameterisation (memory error)	- Carry out initialisation on the master (sensor on the door controller)
The green LED on the slave module lights up permanently	- The master is in standby mode and the slave is not. Only the slave was reactivated.	- Reactivate master using door activation - Carry out initialisation on master (sensor on door controller) - Check test input (parameter 1) - Activate synchr. on all sensors (parameter 9) - Replace ribbon cable if necessary

Note: Carrying out master initialisation or switching the operating voltage off/on will reset an error.

## 5 Technical data

Technology	Active infrared (triangulation)	Making current	< 500 mA
Wavelength	880 nm	Test input	4 versions (high/low active, pull up/down)
Number of IR beams	8, can be switched separately, synchronized	Output	Change-over relay, max. 40 V DC / 40 V AC, 1 A
Dimensions of an IR beam	30 mm x 60 mm at 2.2 m mounting height	Hold intervals	0 – 10 s (adjustable)
Detection zone, dimensions	471 mm x 60 mm at 2.2 m mounting height	Operating temperature	-20 °C bis 60 °C
Response time	< 50 ms	Type of protection	IP54
Mounting height	1.7 – 3.0 m, depending on the background	Remote control range	5 m
Angle setting	2° – 14°, set in increments of 3°	Number of devices that can be interconnected	4 units, synchronized
Installation length in the profile	300 mm incl. mounting clips	Application	Stationary/moving presence detection
Operating voltage	15 – 37 V DC 15 – 26 V AC, 50/60 Hz	Functional safety level	EN ISO 13849-1: PLd EN 61508: SIL2
Power consumption	Max. 3.3 W, 0.17 W per beam		

## 6 EU Declaration of Conformity

 See attachment

## 7 WEEE



Devices with this symbol must be treated separately during disposal. This must be done in accordance with the laws of the respective countries for environmentally sound disposal, processing and recycling of electrical and electronic equipment.

## 8 Contact

**BBC Bircher Smart Access**, BBC Bircher AG, Wiesengasse 20, CH-8222 Beringen, [www.bircher.com](http://www.bircher.com)

Designed in Switzerland / Made in China