



Metal Detectors



Special-Sensors for Automation

Metal Detectors

Contents

Technique and application for Metal Detectors

Overview	8.3
Application notes	8.4 - 8.5

Amplifiers, detector coils and accessories

Amplifier for detector coils Series MDVH 3261	8.6
Amplifier for detector coils Series MDV 3221	8.7
Amplifier for detector coils Series Series MDV 3172	8.8
Amplifier for detector coils Series Series MDV 3173	8.9
Detector coil Series MDS	8.10 - 8.11
Overvoltage protection / Supply isolation unit Series NTG / DTG	8.12
Connection box for the combination of detector coils Series MA 125	8.13
Detector coil extension cable Series KS031-DS	8.14

We reserve the right to make technical alterations without prior notice.

Metal Detectors

Technique & Application

Overview

How to use

System 3000 provides an effective protection solution for industrial equipment such as rock crushers, vibrators and wood chippers. The metal detector detects larger metal objects such as excavator bucket teeth, wrenches and other objects that could cause serious damage to the equipment. In addition, the MDVH 3261 amplifier detects smaller metal objects such as nails or nuts. This combination provides comprehensive protection that effectively minimises machine downtime and repair costs.

Components / setup of the metal detector system

A metal detector system consists of one or two coils and an amplifier. The following diagrams illustrate this with examples.

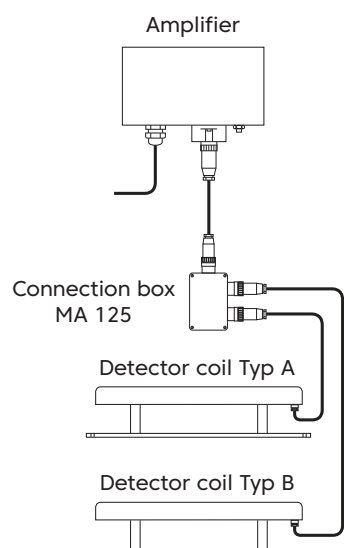
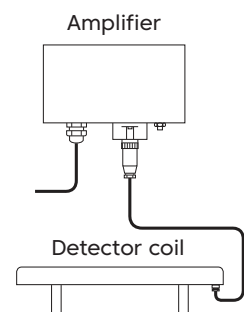

Amplifier

MDV 3172 / 3173



- Robust design with plastic housing
- Fixed cable connection
- Sensitivity adjustable
- 24 V DC / 115 V AC / 230 V AC
- "Fail-safe" logic for switching output for MDV 3173

MDV 3221



- Version with aluminium housing and screw terminal connection
- Sensitivity adjustable
- Internal and external test function
- Extended control range for surrounding metal
- Diagnostic function / LED
- 24 V DC / 230 V AC
- "Fail-safe" logic selectable for switching output

MDVH 3261



- Higher sensitivity for more applications
- Version with aluminium housing and screw terminal connection
- Sensitivity adjustable
- Internal and external test function
- Extended control range for surrounding metal
- Diagnostic function / LED
- 24 V DC / 230 V AC
- "Fail-safe" logic selectable for switching output

Detector coils

The coils are available in three different widths:

Coil type A

- MDS 3065-SA:** 650 mm
- MDS 3075-SA:** 750 mm
- MDS 3095-SA:** 950 mm

Coil type B (for combination of coils)

- MDS 3065-SB:** 650 mm
- MDS 3075-SB:** 750 mm
- MDS 3095-SB:** 950 mm



Accessories

Protection for faulty mains

- DTG 24 (24 V DC)**
- NTG 251 (230 V AC)**
- NTG 255 (115 V AC)**



Connection box for the simultaneous use of two coils

MA 125



Extension cable for coils

KS031-DS



Metal Detectors

Technique & Application

Application notes

How to use

The EGE metal detection system is an efficient solution for detecting metal objects in industrial applications. It consists of one or two MDS series detection coils and an MDV or MDVH amplifier. The system detects metal objects, for example on conveyor belts, and sends a signal to the connected control system. This prevents damage to system components before costly repairs become necessary. It protects the system, reduces repair costs and can be easily integrated into existing control systems.



Function

The detector coil produces an electromagnetic field. When a sufficiently large metal object passes through this field, the change in field strength is detected by the amplifier unit, which activates a relay. A potentiometer can be used to adjust the sensitivity so that only objects above a certain size are detected. Metal parts of the conveyor belt construction and the mounting of the detector coil are masked out in the adjustment range to prevent malfunction.

The switching logic of the output relay can be changed to "fail-safe" logic on the MDV 3221 and MDVH 3261, while it is fixed on the MDV 3173. In addition, the MDV 3221 and MDVH 3261 offer a test function that can be started either by a button on the unit or by an external voltage. This test function simulates the damping of the system by metal and tests the entire processing chain.

Detection sensitivity depends on the type of metal and the speed of the conveyor belt.

Mounting

The detector coil is mounted on an aluminium plate with spacers. This provides both shielding against electromagnetic interference from the ground and a stable mounting. In locations with electromagnetic interference, it is recommended that the coil is additionally shielded at the sides, for example with aluminium plates.

The detector coil is installed under the conveyor belt to detect metal objects in the material being conveyed. Ensure that there is a sufficient distance (B) from metal components such as conveyor rollers to avoid possible interference. The base plate should be securely bolted to the conveyor structure to prevent vibration.

To minimise the risk of shocks to the detector coil from a swinging or sagging belt, it is recommended that a safety beam be installed to absorb such shocks.

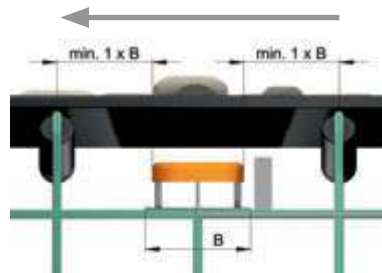

The evaluation unit can be installed either close to the coil or further away, for example in the control room or machine area. To minimise interference, cables carrying high currents or powering frequency controlled motors should be kept well away from the metal detector system components.

Mounting above the conveyor belt

This type of installation is only intended for special cases where other types of installation are not possible. It must be

ensured that the stacked material does not come into contact with the detector coil to avoid damage.

The coil must not be suspended freely from chains or similar.

Dealing with surrounding metal

The more surrounding metal (e.g. conveyor frame), the harder the leveling system has to work. The distance between the coil and such metal also plays a role. The diagnostic LED (MDVH 3261 and MDV 3221 only) helps with the design: it uses flashing codes to indicate if there is a borderline amount of surrounding metal.

Separate Metal Detector Systems

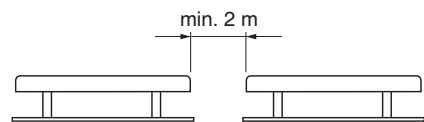

If two detector coils are to be operated, each with its own amplifier, a minimum lateral distance of 2 metres is required between the coils. Otherwise the coils may influence each other, resulting in interference or false alarms.

Metal Detectors

Technique & Application

Application notes

Combination of two detector coils

Two detector coils can be connected to a single amplifier. This requires the use of the MA 125 connection box. In addition, one coil must be of type A and one of type B.

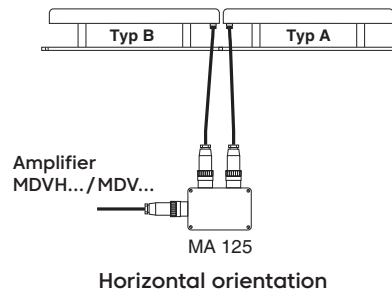

The horizontal orientation and the V-position (see drawing) are used to increase the detection range, e.g. on wider conveyor belts. The distance between the two coils should be as small as possible.

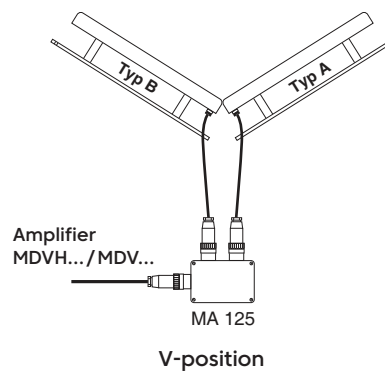

The stacked arrangement of the coils is used to increase the detection area vertically, e.g. to allow a higher load on the conveyor belt.

When stacked, the distance D can be greater than twice the operating distance of a single coil.

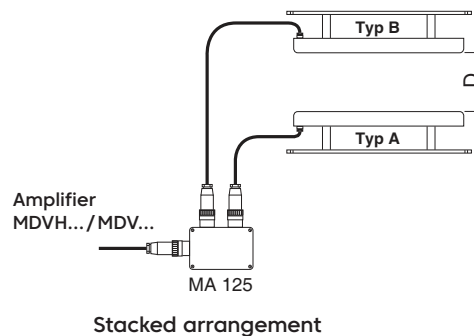

Protection for faulty mains DTG / NTG

The mains isolator is connected between the mains supply and the MDV.../MDVH... amplifier and is used to protect the amplifier from mains over-voltages and overloads. It is particularly useful where there is no overvoltage protection, where power is supplied via overhead mains or unregulated chargers, or where large inductances such as motors are directly switched on. The mains isolator also acts as a noise filter by reducing electromagnetic interference. The potential-free change-over output contact is designed for connection to a control contactor, but is not suitable for operating large loads.



Amplifier for detector coils

- Higher sensitivity for more applications
- Sensitivity adjustable
- Internal and external test function
- Extended control range for surrounding metal
- Diagnostic LED for faster setup
- "Fail-safe" logic selectable for switching output



Design MDVH 3261

Dimensions

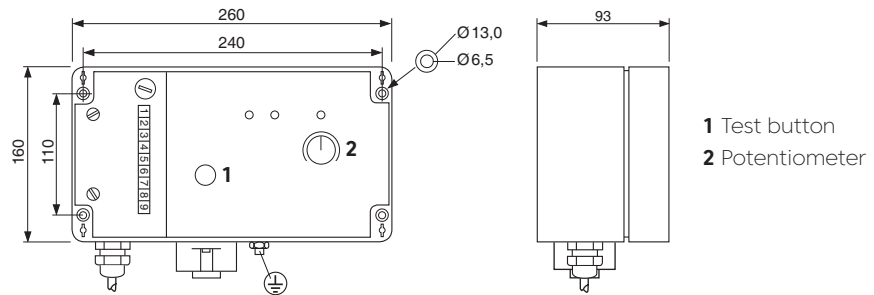

ID-No.	P81066	P81067
Type	MDVH 3261 GR	MDVH 3261 WR
Supply voltage [V]	24 DC ±10%	230 AC ±10%
Current consumption [mA]	< 250	< 50
Output	Relay / Change-over contact	
Switching voltage	250 V AC / 220 V DC	
Switching current	1 A AC / 2 A DC	
Switching power	125 VA / 60 W	
Test input [V]	≤ 24 DC	
Ambient temperature [°C]	-25...+60	
Protection [EN 60529]	IP 67	
Display	LED	
Clamping area		
Cable gland [mm]	4...10	
Housing material	Aluminium	
Connection	Screw terminals	

Note:
 The sensitivity of the system can be adjusted using the potentiometer.
 The test function can be used to check the complete operation of the MDVH 3261 with the detector coil connected. The test is triggered by pressing the test button or by applying a voltage to the test input.

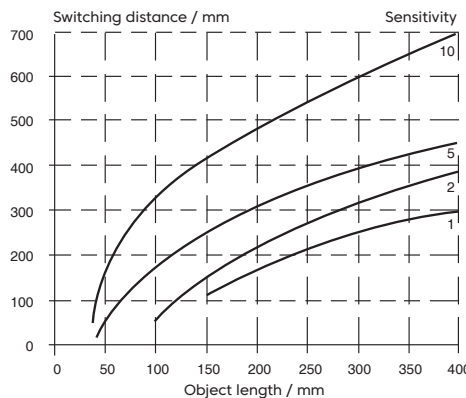

Maximum sensitivity with ST 37 sample



Amplifier for detector coils

- Sensitivity adjustable
- Internal and external test function
- Extended control range for surrounding metal
- Diagnostic LED for faster setup
- "Fail-safe" logic selectable for switching output



Design MDV 3221

Dimensions

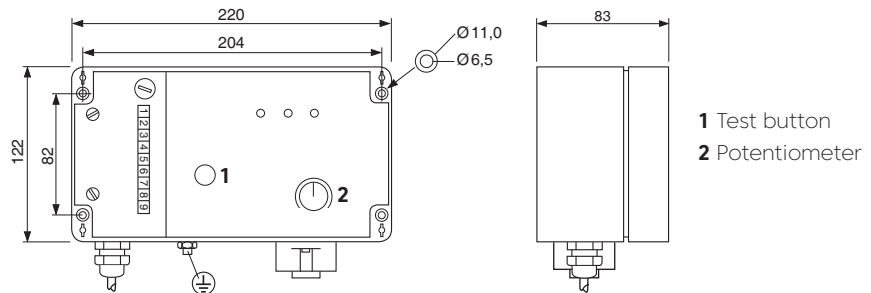

ID-No.	P81068	P81069
Type	MDV 3221 GR	MDV 3221 WR
Supply voltage [V]	24 DC ±10%	230 AC ±10%
Current consumption [mA]	< 100	< 20
Output	Relay / Change-over contact	
Switching voltage	250 V AC / 220 V DC	
Switching current	1 A AC / 2 A DC	
Switching power	125 VA / 60 W	
Test input [V]	≤ 24 DC	
Ambient temperature [°C]	-25...+60	
Protection [EN 60529]	IP 67	
Display	LED	
Clamping area		
Cable gland [mm]	4...10	
Housing material	Aluminium	
Connection	Screw terminals	

Note:

The sensitivity of the system can be adjusted using the potentiometer. The test function can be used to check the complete operation of the MDV 3221 with the detector coil connected. The test is triggered by pressing the test button or by applying a voltage to the test input.

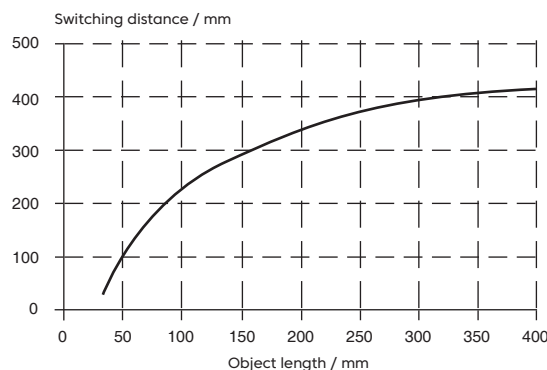

Maximum sensitivity with ST 37 sample



Amplifier for detector coils

Rugged design with plastic housing

Automatic control range for surrounding metal

Sensitivity adjustable



Design MDV 3172

Dimensions

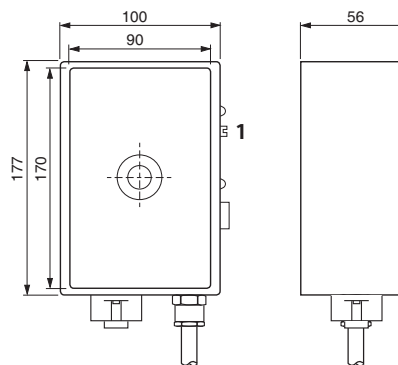

1 Potentionmeter

ID-No.	P81011	P81010	P81017
Type	MDV 3172 GR	MDV 3172 WR2	MDV 3172 WR1
Supply voltage [V]	24 DC ±10%	230 AC ±10%	115 AC ±10%
Current consumption [mA]	< 100	< 20	< 60
Output	Relay / Change-over contact		
Switching voltage	250 V AC / 220 V DC		
Switching current	1 A AC / 2 A DC		
Switching power	125 VA / 60 W		
Ambient temperature [°C]	-25...+60		
Protection [EN 60529]	IP 67		
Display	LED		
Housing material	PBT		
Connection	2 m PVC cable 7x0.5 mm ²		

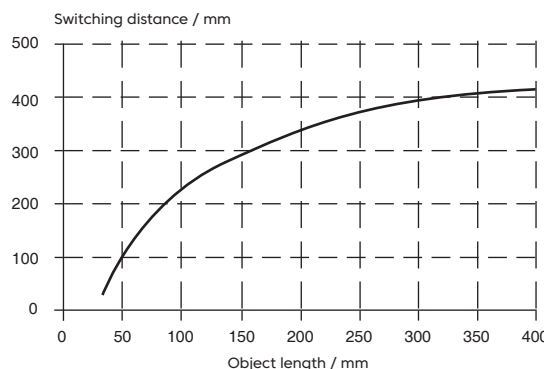

Maximum sensitivity with ST 37 sample

Accessories Central screw M16x1 (Z00105) is part of delivery



Amplifier for detector coils

Rugged design with plastic housing

Automatic control range for surrounding metal

Sensitivity adjustable

"Fail-safe" logic permanently set for switching output



Design	MDV 3173		
<i>Dimensions</i>	<p>1 Potentionmeter</p>		
ID-No.	P81064	P81063	P81065
Type	MDV 3173 GR	MDV 3173 WR2	MDV 3173 WR1
Supply voltage [V]	24 DC $\pm 10\%$	230 AC $\pm 10\%$	115 AC $\pm 10\%$
Current consumption [mA]	< 100	< 20	< 60
Output	Relay / Change-over contact		
Switching voltage	250 V AC / 220 V DC		
Switching current	1 A AC / 2 A DC		
Switching power	125 VA / 60 W		
Ambient temperature [°C]	-25...+60		
Protection [EN 60529]	IP 67		
Display	LED		
Housing material	PBT		
Connection	2 m PVC cable 7x0.5 mm ²		

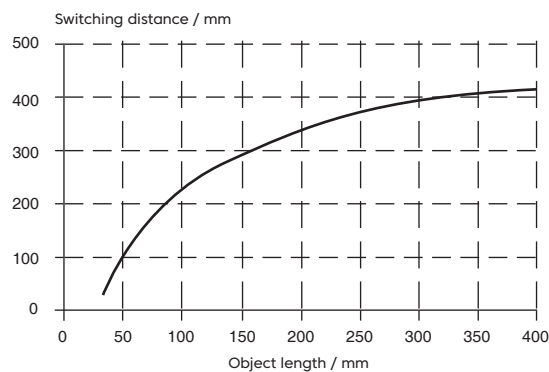

Maximum sensitivity with ST 37 sample

Accessories

Central screw M16x1 (Z00105) is part of delivery



Detector coils

Designed for outdoor use

Rugged construction

High stability



Design	MDS 3065-S		MDS 3075-S	
Dimensions				
	ID-No.	P81054	P81055	P81070
Type	MDS 3065-SA	MDS 3065-SB	MDS 3075-SA	MDS 3075-SB
Coil type	A	B	A	B
Ambient temperature [°C]	-25...+70			
Protection [EN 60529]	IP 67			
Housing material	PBT / Aluminium plate			
Connection	3 m PUR cable with cable plug			
Note:	If two coils are to be connected to an amplifier via the MA 125 connection box, one type A coil and one type B coil must be used.			
Accessories	Connection box MA 125 p. 8.13, Extension cable for coils KS031-DS..., p. 8.14			



Detector coils

Designed for outdoor use

Rugged construction

High stability



Design	MDS 3095-S	
Dimensions		
ID-No.	P81056	P81057
Type	MDS 3095-SA	MDS 3095-SB
Coil type	A	B
Ambient temperature [°C]	-25...+70	
Protection [EN 60529]	IP 67	
Housing material	PBT / Aluminium plate	
Connection	3 m PUR cable with cable plug	
Note:	If two coils are to be connected to an amplifier via the MA 125 connection box, one type A coil and one type B coil must be used.	
Accessories	Connection box MA 125 p. 8.13, Extension cable for coils KS031-DS..., p. 8.14	



Overvoltage protection | Power supply isolation device

- Limits mains overvoltages
- Protects the amplifier from overload
- Acts as a noise filter
- Floating change-over output contacts
- Quick mounting on standard rail (DIN EN 50022)



Design DTG / NTG

Dimensions

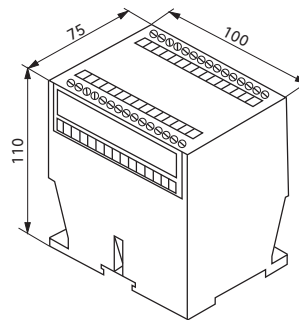

ID-No.	P81053	P81030	P81032
Type	DTG 24	NTG 251	NTG 255
Output	Relay	Relay	Relay
Supply voltage [V]	19...30 DC	230 AC ±15%	115 AC ±15%
Power consumption [VA]	6	8	8
Output voltage	24 V DC ±2%	230 V AC ±15%	115 V AC ±15%
Output	Relay / Change-over contact		
Switching voltage max. [V]	250 AC		
Switching current max. [A]	4 AC		
Switching power max.	1000 VA / 60 W		
Ambient temperature [°C]	-25...+60		
Protection [EN 60529]	Terminals: IP 20 / Housing: IP 40		
Display	LED		
Connection	Screw terminals		

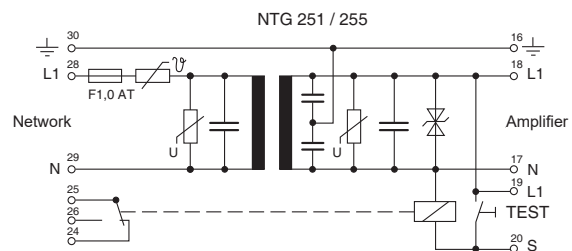
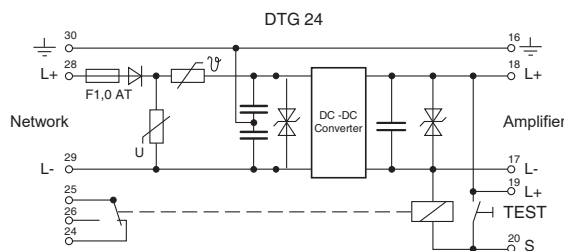



Connection box for detector coils

Connection box for the combination of detector coils



Design	MA 125
Dimensions	
ID-No.	P81058
Type	MA 125
Ambient temperature [°C]	- 25...+60
Protection [EN 60529]	IP 67
Housing material	Aluminium, painted
Connection	Plug connection, 2x socket / 1x plug

Two detector coils can be operated together with one MDVH / MDV... using the MA 125 connection box. The maximum cable length between a coil and the MA 125 connection box is 3 m.

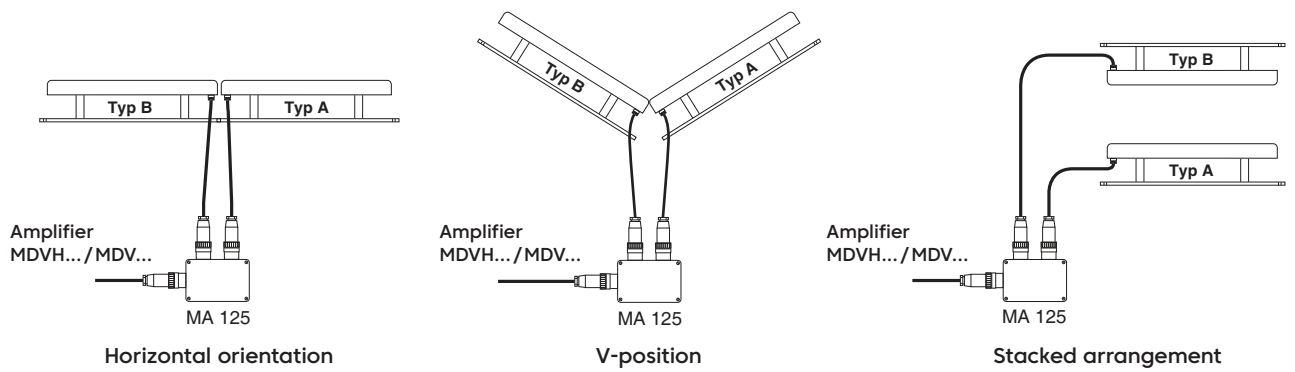



Extension cable for detector coil

The extension cable KS031-DS connects the detector coil MDS... with the amplifier MDVH... / MDV...



Design KS031-DS

Dimensions

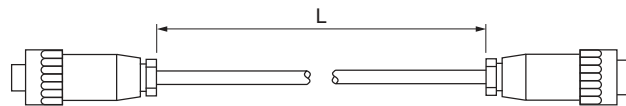

ID-No.	P81051	P81052	
Type	KS031-DS05	KS031-DS10	KS031-DSXX
Cable length L [m]	5	10	length on request
Cable shield		•	
Cable material		PUR	
Protection [EN 60529]		IP 67	
Connection		Socket, plug	

The KS031-DS detector coil extension cable is designed for use with 3000 series metal detectors. Its rugged construction and tough PUR jacket means it will not generate interference that could cause an error signal in the amplifier.

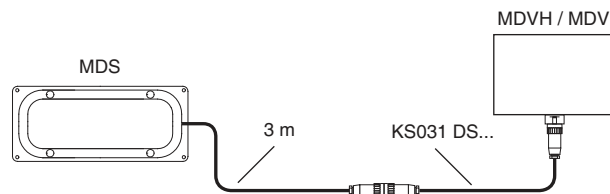

Process Sensors

Flow sensors

- Electronical monitoring of flow
- Lubrication monitoring
- Measuring range 1 ml/min...100 l/min
- Detection range 1...300 cm/s
- Reaction time 0.5 s

Level sensors

- For level monitoring $-230...+230\text{ }^{\circ}\text{C}$
- Steam proof at a pressure of up to 30 bar
- For hot motor oil
- For liquid nitrogen
- For chemically aggressive media

Infrared detectors

- Measurement of temperature
- Monitoring of hot media
- Position control

Temperature sensors

- Monitoring in pipes and containers
- Temperature $-40...+120\text{ }^{\circ}\text{C}$ ($\pm 0,3\text{ }^{\circ}\text{C}$)
- Pressure up to 100 bar
- Compact models
- Multi use output NO/NC + analog

Pressure sensors

- Monitoring in pipes and containers
- Pressure up to 16 bar
- Level up to 10 m ($\pm 1\text{ cm}$)
- Compact models
- Programmable

Ultrasonic sensors

- Switching distance up to 6000 mm
- Level monitoring
- Watertight housing
- Teach-in functions



Sales partners, wholesalers and representatives



ARGENTINA, Lomas de Zamora
AUSTRALIA, Warabrook NSW 2304
AUSTRIA, Wien
BELGIUM, Aalst
BRAZIL, Sao Paulo
CANADA, Oldcastle – Ontario
CHINA, Shanghai
COLOMBIA, Bogota D.C.
CZECH REPUBLIC, Ostrava
DENMARK, Aabenraa
ESTONIA, Tallinn
FINLAND, Jyväskylä
FRANCE, Nanteuil les Meaux
GREECE, Sindos - Thessaloniki

GREAT BRITAIN, Staffordshire
HUNGARY, Budapest
INDIA, Mumbai
IRELAND, Clane, Co. Kildare
ISRAEL, Tel-Aviv
ITALY, Carate Brianza (MI)
JAPAN, Tokyo
NAMIBIA, Windhoek
NETHERLANDS, LG Dordrecht
NEW ZEALAND, Greenmount,
Auckland
NORWAY, Kolsås
PHILIPPINES, Taguig City
POLAND, Jezow Sudecki
POLAND, Katowice

RUSSIAN FEDERATION, Moscow
PORTUGAL, Porto
ROMANIA, Bucharest
SINGAPORE, Singapore
SLOVAKIA, Banská Bystrica
SLOVENIA, Ljubljana - Crnuce
SOUTH AFRICA, Cleveland
SOUTH KOREA, Gwangmyeongsi,
Gyeonggi-do
SPAIN, Nigran
SWEDEN, Borås
SWITZERLAND, Uster
TAIWAN, New Taipeh City
TURKEY, Kurtköy / Pendik / Istanbul
USA, Gastonia
VIETNAM, Ho Chi Minh City



<https://www.ege-elektronik.com/company/about-us>

We look forward to your enquiry.
Please contact us!

EGE-Elektronik
Spezial-Sensoren GmbH
Ravensberg 34 • 24214 Gettorf • Germany
T +49 (0) 4346-41580 F +49 (0) 4346-5658
info@ege-elektronik.com
ege-elektronik.com

EE80325

