

# Pressure Sensors



Special-Sensors for Automation

# Pressure Sensors

## Technique & Application

### Application

Devices of the series DN monitors pressure levels in pipes and containers. However, the high accuracy of its capacitive ceramic gauge head makes it an effective fill level monitor as well. It can record fill levels with an accuracy of one centimeter in containers that stand five meters tall. Measurement instruments with a 1000 mbar measurement range have proven to be very useful for these types of applications. When measuring the fill level of water, 10 mbar of pressure corresponds to 10 cm water height. The instrument displays the pressure value digitally. The fill level measurement is not effected by foam on the liquid's surface. Suspended matter inside the container will not effect the measurement either - as long as the matter does not disturb the pressure distribution in the area surrounding the sensor membrane. The pressure sensor is a compact device that contains all the measurement and evaluation electronics. It is designed for use with 24 V DC. In addition to many programmable features, it also provides two PNP switch outputs and a 4 to 20 mA current output. Additionally we offer a model with 2 switching points and a rapid programming feature which can be used, for example, for minimum and maximum detection in a container. A model with one analog output only is also available.

### Functionality

The pressure sensor is designed to be screwed into the wall of a pressure container or a pipe. The medium contacts the sensor's ceramic gauge head directly. A pressure mediating fluid is not used. The dry capacitive gauge head provides a high level of overload stability. The medium pressure will cause the measurement membrane to deflect by a maximum of 0.03 mm. At maximum deflection, the membrane lies against the ceramic carrier, thereby enabling an instrument designed for a pressure range of 0 to 16 bar to withstand an overload or pressure spike of up to 64 bar without being damaged. When the overload passes, the membrane returns to its neutral position without exhibiting any hysteresis. Deflection of the membrane against the ceramic carrier effects a capacity change that the integrated micro-processor-controlled evaluating electronics convert into a pressure-proportional DC signal of 4 to 20 mA. The measurement value is displayed on the four-digit LED display, whereby all values can be freely scaled to four digits with up to three decimal places. The signal can be processed internally with buffering of up to 30 seconds, thereby making it possible to diminish pressure spikes in pipes. Three buttons and a four-digit LED display

enable the user to calibrate the sensor measurement range and to program the PNP switch outputs, and the buffering. Only a few button combinations are required to rapidly complete configuration. Both integrated PNP switch outputs are freely programmable, allowing the user to adjust the limit value, hysteresis, and functionality type (normally closed or normally open) as needed. A LED signals the switching condition of the PNP switch outputs. The programmed data is stored in an EEPROM, providing security even in the event of power failure. The sensors DN 752 GPP and DN 752 GA have a three-digit LED display and they allow a fast and easy programming for either two switchpoints or one analog output.

For measurement and monitoring of gases of low pressures (0...30 mbar) use the pressure controller DN 752 GA-003 with analog output.

### Sealing materials

The sensor membrane must be resistant to the medium in which the sensor will be used. A fluoroelastomer (FPM) gasket is standard equipment.

### Installation of the pressure sensor

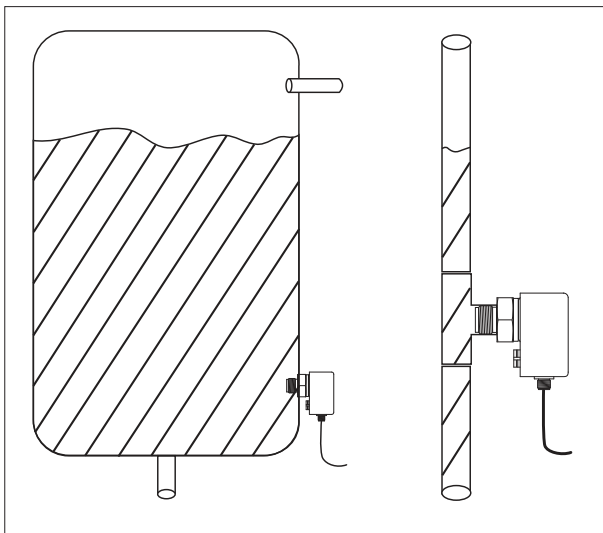

### Resistance characteristics

Sign	FPM	EPDM	NBR	Kalrez
Trade name	Viton	Keltan	Perbunan	Kalrez
Water	++	++	++	++
Aromatic hydrocarbons	++	-	-	++
Halogenated solvents	+	-	-	+
Acid	++	+	-	++
Lye	-	++	+	++
Vegetable oil	++	-	++	++
Animal fat	++	-	++	++
Fuel	++	-	+	++
Lubricating oil	++	-	+	++
Hydraulic oil	++	-	+	++



## Two switching points

Monitoring sensor for gases and fluids

Fast and easy programming

Two independent switching points

7-segment display

Display rotatable



**Design** **DC PNP • G3/4**

**Dimensions**

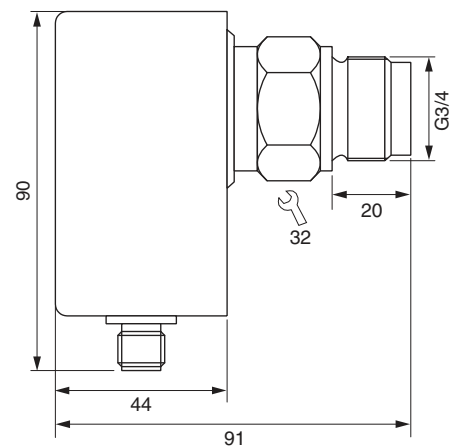
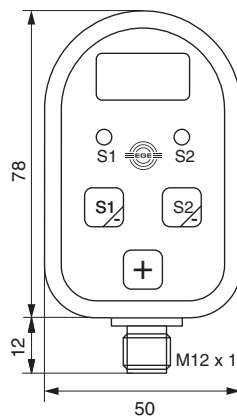

Sensing range	[bar]	0...1 relative	0...16 relative
Output		2 x  PNP NO	
ID-No.		P72014	P72015
Type		DN 752 GPP-01	DN 752 GPP-16
Supply voltage	[V]	24 DC ±20%	
Switching current	[mA]	200	
Current consumption	[mA]	<50	
Ambient temperature	[°C]	-20...+70	
Medium temperature	[°C]	-20...+80	
Compressive strength	[bar]	5	48
Sensor material		AISI 316 Ti	
Material gauge head		Ceramic	
Sealing material		FPM	
Housing material		PBT	
Protection	[EN 60529]	IP 65	
Connection		M12 connector	

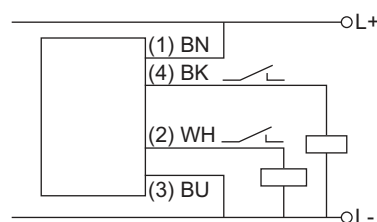
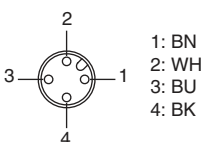

**Accessories** Connecting cable type SLG 4-2 (Z00445)



# Analog output

Monitoring sensor for gases and fluids

Fast and easy programming

Analog output model

7-segment display  
Display rotatable



**Design** **DC • G3/4**

*Dimensions*

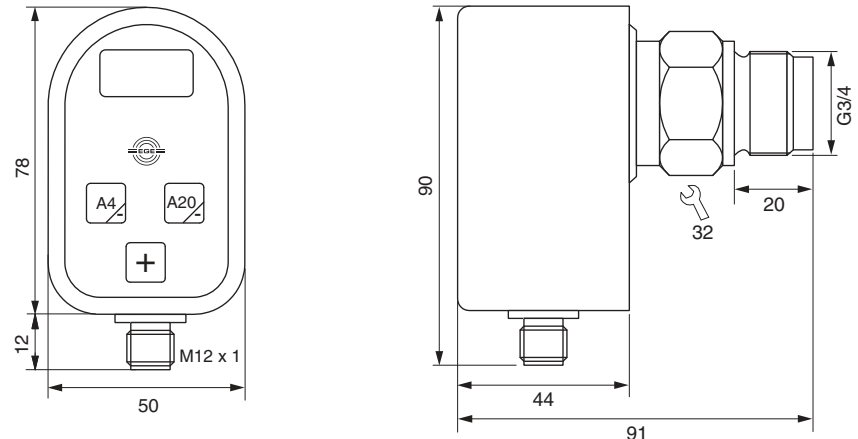

Sensing range	[bar]	0...1 relative	0...16 relative
Output		—( )— 4...20 mA	
ID-No.		P72016	P72017
Type		DN 752 GA-01	DN 752 GA-16
Supply voltage	[V]	24 DC ±20%	
Current output	[mA]	4...20 linear	
Load R <sub>L</sub>	[Ω]	200...500	
Current consumption	[mA]	<50	
Ambient temperature	[°C]	-20...+70	
Medium temperature	[°C]	-20...+80	
Compressive strength	[bar]	5	48
Sensor material		AISI 316 Ti	
Material gauge head		Ceramic	
Sealing material		FPM	
Housing material		PBT	
Protection	[EN 60529]	IP 65	
Connection		M12 connector	

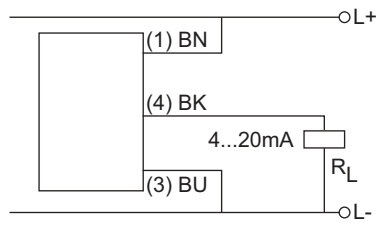
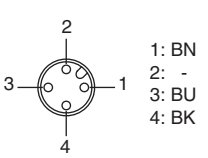

**Accessories** Connecting cable type SLG 3-2 (Z01076)



# Two switching points and analog output

Monitoring sensor for gases and fluids

Linear current output 4...20 mA

Two programmable switching points

NC/NO programmable

Display rotatable



**Design** **DC • G3/4**

*Dimensions*

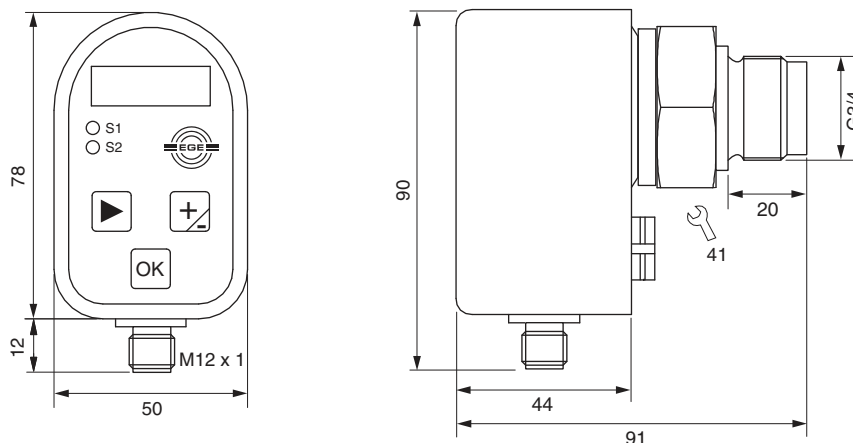

Sensing range	[bar]	0...1 relative	0...16 relative
Output		2 x  PNP NC/NO +  4...20 mA	
ID-No.		P72012	P72013
Type		DN 752 GAPP-01	DN 752 GAPP-16
Supply voltage	[V]	24 DC ±10%	
Current output	[mA]	4...20	
Switching current	[mA]	200	
Load R <sub>L</sub>	[Ω]	0...400	
Current consumption	[mA]	20	
Ambient temperature	[°C]	-20...+70	
Medium temperature	[°C]	-20...+80	
Compressive strength	[bar]	16	64
Sensor material		AISI 316 Ti	
Material gauge head		Ceramic	
Sealing material		FPM	
Housing material		PBT	
Protection	[EN 60529]	IP 67	
Connection		M12 connector	

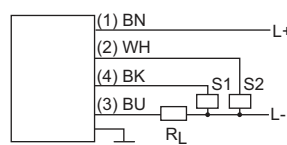
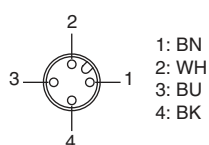

Accessories Connection cable type SLG 4-2 (Z00445)



## Switching points and analog output

### Additional technical data DN 752 GAPP...

Output analog	4...20 mA	
Linearity	≤0.2%	of maximum value
Temperature drift	≤0.1% / 10 K	of maximum value
Long time drift	≤0.1% / Year	of maximum value
Influence of supply voltage	≤0.5% / 10 V	of maximum value
Input/output resolution	16 Bit	
Alignment range	zero point 0% - 95% / final point 3,3% - 100%	
Adjustment range of damping	0...30 seconds	

### Switching output

S1 / S2	PNP NO/NC programmable
Output voltage	+U <sub>B</sub> - 1.5 V
Time delay	< 8 ms
Rise time	< 400 μs with R <sub>L</sub> < 400 Ω or I <sub>L</sub> > 4.5 mA, respectively

### Characteristics

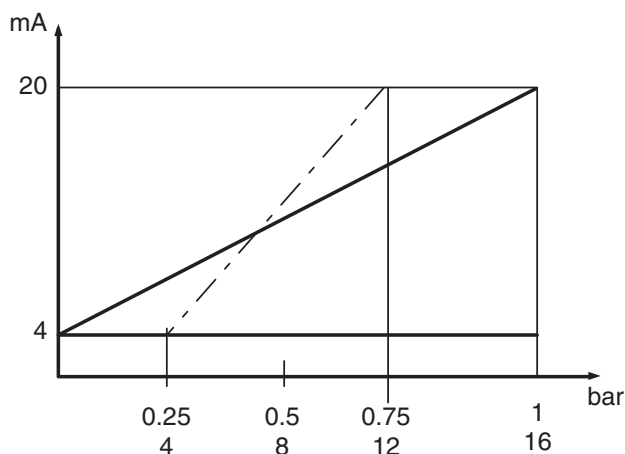

### Notice

Install signal and measurement wires separate from power-carrying wires. Use only shielded wires for signals and measurement. Ground the shield only on one side. Operate inductive loads like relays or auxiliary contactors (used to avoid voltage spikes) only with a recovery diode or a RC module.

Before installation, make sure that the sensor membrane's gasket is suitable for the medium you will use. Our factory provides a fluoroelastomer (FPM) gasket.

The sensor is delivered with pre-programmed default settings. You must first enter an access code if you wish to change the programmed parameters to meet your requirements. Please refer to the operating instructions manual for this code.

### Default setting

The pressure sensor is programmed at the factory to enable immediate use with a default setting for the analogue output. The digital display shows the current pressure value.

### Operational and display elements

The display has four digits and shows the current pressure during operation. The LEDs for the S1 (SP1) and S2 (SP2) switching points illuminate when the respective switch output is activated.

During the programming procedure, the LED display will show (alpha-numerically) either the numeral value just entered or the respective program step.

### Front view

7 segment LED display

LED for each switching point

Keypad for programming

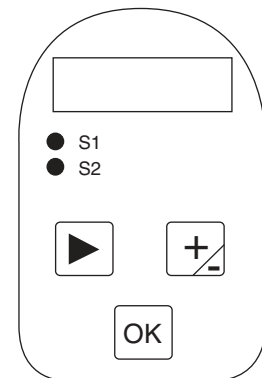

Program the sensor by means of the programming buttons:

- OK button:** Enter the submenu and accept the selected values.
- Arrow button:** Jumps from one spot in the menu to another. Changes the +/- button's direction of action. Changes the setting in a selection menu.
- +/- button:** Adjusts the displayed value. Hold this button depressed to run quickly through the values.

The operating instructions describe how to program the operational parameters.



# Analog output

Monitoring sensor for gases

Sensing range 0...30 mbar relative



**Design** **DC • G3/4**

*Dimensions*

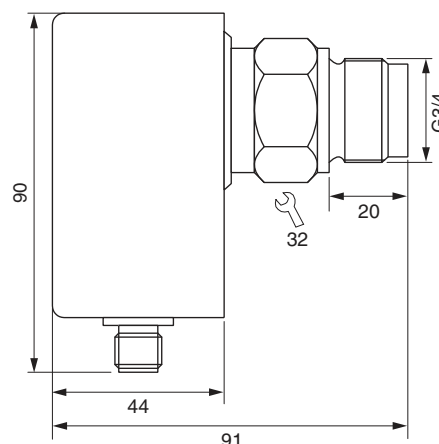
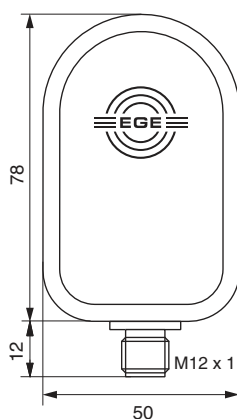

Sensing range [mbar]	0...30 relative
Output	4...20 mA
ID-No.	P72032
Type	DN 752 GA-003
Supply voltage [V]	24 DC ±10%
Load RL [Ω]	200...500
Current consumption [mA]	< 20
Ambient temperature [°C]	-20...+70
Medium temperature [°C]	-20...+70
Compressive strength [mbar]	160
Sensor material	AISI 316 Ti
Material gauge head	Ceramic
Sealing material	FPM
Housing material	PBT
Protection [EN 60529]	IP 60

**Connection** **M12 connector**

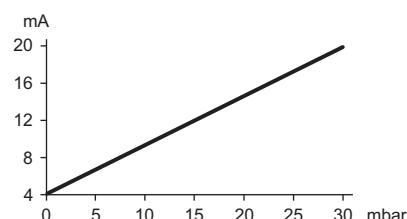
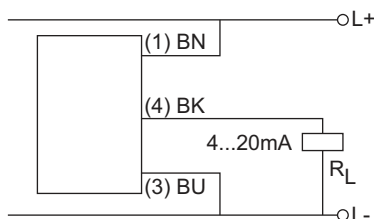
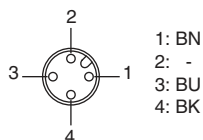

**Accessories** **Connection cable type SLG 3-2 (Z01076)**

# Sales partners, wholesalers and representatives



ARGENTINA, Lomas de Zamora  
AUSTRALIA, Warabrook NSW 2304  
AUSTRIA, Wien  
BELGIUM, Aalst  
BRAZIL, Sao Paulo  
CANADA, Oldcastle – Ontario  
CHINA, Shanghai  
COLOMBIA, Bogota D.C.  
CZECH REPUBLIC, Ostrava  
DENMARK, Aabenraa  
ESTONIA, Tallinn  
FINLAND, Jyväskylä  
FRANCE, Nanteuil les Meaux  
GREECE, Sindos - Thessaloniki

GREAT BRITAIN, Staffordshire  
HUNGARY, Budapest  
INDIA, Mumbai  
IRELAND, Clane, Co. Kildare  
ISRAEL, Tel-Aviv  
ITALY, Carate Brianza (MI)  
JAPAN, Tokyo  
NAMIBIA, Windhoek  
NETHERLANDS, LG Dordrecht  
NEW ZEALAND, Greenmount,  
Auckland  
NORWAY, Kolsås  
PHILIPPINES, Taguig City  
POLAND, Jezow Sudecki  
POLAND, Katowice

RUSSIAN FEDERATION, Moscow  
PORTUGAL, Porto  
ROMANIA, Bucharest  
SINGAPORE, Singapore  
SLOVAKIA, Banská Bystrica  
SLOVENIA, Ljubljana - Crnuce  
SOUTH AFRICA, Cleveland  
SOUTH KOREA, Gwangmyeongsi,  
Gyeonggi-do  
SPAIN, Nigran  
SWEDEN, Borås  
SWITZERLAND, Uster  
TAIWAN, New Taipeh City  
TURKEY, Kurtköy / Pendik / Istanbul  
USA, Gastonia  
VIETNAM, Ho Chi Minh City



<https://ege-elektronik.com/en/organisation/ege/>

We look forward to your enquiry.  
Please contact us!

EGE-Elektronik  
Spezial-Sensoren GmbH  
Ravensberg 34 • 24214 Gettorf • Germany  
T +49 (0) 4346-41580 F +49 (0) 4346-5658  
info@ege-elektronik.com  
**ege-elektronik.com**

EP71120

