

Operating Instructions

Fork Light Barrier

FS-Series

All technical specifications refer to the state of the art 05/2011, they are subject to modifications.



Warning!

The fork light barriers FS... are not safety systems and should not be used as such systems. The devices are not be used for applications where personal safety is dependent on their function.

The operator of the higher-level overall system, e.g. a machine installation, is responsible for complying with the national and international safety and accident prevention regulations which apply to the specific use.

Mounting and electrical connections of the fork light barrier must be performed by a person trained to follow legal regulations and without voltage applied to the machine. The machine must be secured to prevent unintentional restart.

Product description

The fork light barriers are to be used for the contact free detection of objects in machines or production systems. They are a combination of a transmitter and receiver in one case, which works on the principle of through-beam light barriers. Thanks to the complete integration of the electronics into one case, simple installation and alignment is possible.

The FS-Series has a high resolution, operating accuracy, and reproducibility which is the prerequisite for exact position detection. They distinguish themselves by the high variability, by the adjustable fork width and flexibility, by comprehensive settings.

Operation mode

The operation mode determines the method of adjustment for the transmit power to the ambient conditions. Selectable is:

- Automatic - The transmit power will be adjusted automatically depending on the ambient conditions.
- Manual - The transmit power will be adjusted manually depending on the to the ambient conditions by the user.
- Teach ignore - The transmit power will be adjusted automatically to a given object, so that the object will not be detected.

Switching output type

The switching output type determines the transistor type of switching output.

Selectable is:

- PNP - The switching output has a transistor which switches the load to the positive supply voltage U_B .
- NPN - The switching output has a transistor which switches the load to the negative supply voltage 0V.
- PNP/NPN - The switching output has one transistor which switches the load to the positive supply voltage U_B and one transistor which switches the load to the negative supply voltage 0V. Only one transistor is switched.

Impulse stretching

The impulse stretching stretches the switching pulse of the output. Selectable is:

- Off - The impulse stretching is off.
- 1 ms - The switching pulse has at least 1 ms.
- 10 ms - The switching pulse has at least 10 ms.
- 100 ms - The switching pulse has at least 100 ms.

Switching behaviour

The switching behavior describes the behavior of the switching output on interruption or clearance of the infrared beam. Selectable is:

- Light switching - The switching output will be activated when light is on the receiver.
- Dark switching - The switching output will be activated when no light is on the receiver.

Scope of supply

The following parts are included in the scope of supply. If all parts are not included, please contact the vendor from which you brought the product.

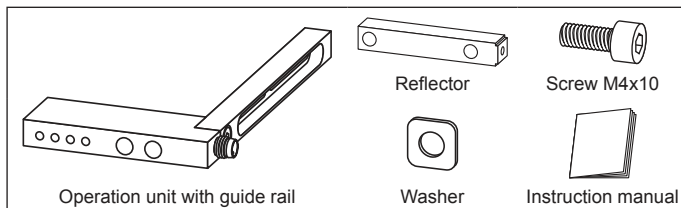

Mounting

Monting instructions

Please note the following instructions:

- Please check, with help of the technical data, if the fork light barrier is acceptable for your application.
- The object that will be detect must pass the fork opening without any contact.
- The mounting should be configured so that unintentional adjustment is impossible.
- The releasing of the fastener should be only possible with tools.

Fork width adjustment

You need a hexagon socket wrench size 3mm for the adjustment of the fork width. Set the reflector to desired distance. The optic must be visible to the operation unit. Put the washer on the enclosed hexagon screw M4x10. Use the hexagon socket wrench to twist the screw tightly (max. tightening torque 2 Nm).

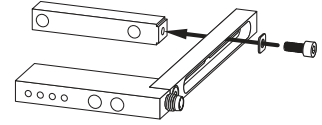

Note!

The screw is furnished with locking varnish. In a repeated loosening necessary (> 4 times), then must the screw coat again with locking varnish.

Mechanical mounting

The fork will be mounted with M4 screws. You can see the mounting points in the drawing on the right side. The exact position is shown in the dimensional drawing.

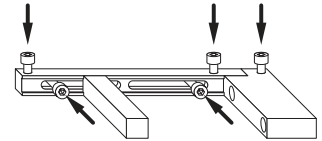

Electrical connection

Connection plug



Attention!

The plug must be connected or removed without power applied.

The fork light barrier will be connect with the 3-pole circular plug connector ⑦. The supply voltage should not be lower than +12 V DC or higher than +30 V DC. Voltage outside these limits can restrict the correct function or damage the sensor.

	Connection	Symbol	Description
④	Pin 1	+ U_B	Operation voltage +
①	Pin 4	S	Switching output
③	Pin 3	0V	Operation voltage 0V

Connection diagram

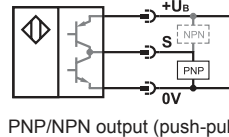
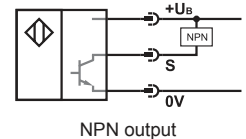
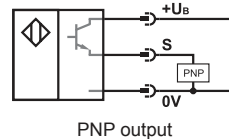

Technical Data (20°C, 24 V DC)

Operating voltage	+12 V DC ... +30 V DC
Current consumption I_B ($I_{OUT} = 0$ mA)	max. 20 mA
Switching output	PNP / NPN / PNP-NPN
Output voltage	$U_B > U_{OUT} > (U_B - 0,3V)$
max. load I_{OUT}	200 mA
Voltage drop	1,3 V
max. Switching frequency	4 kHz (...-S-B3 = 10 kHz)
Resolution (smallest detectable part)	1,0 mm
Reproducibility	0,1 mm
Pulse stretching	0 / 1 / 10 / 100 ms
Ambient light immunity	60.000 Lux
Electrical connection	3-pole plug M8x1 with snap and screw locking
Connection cable	length max. 50 m
Housing material	aluminum black anodized
EMV-standard	EN 60947-5-2
Protection class	IP67
Operation temperature	-10 °C ... +60 °C
Storage temperature	-25 °C ... +80 °C

• Device description

- ① Switching output display (OUT)
- ② Signal display (SIGNAL)
- ③ Alarm display (ALARM)
- ④ Power on display (ON)
- ⑤ PROGRAM button (PROG [-])
- ⑥ RESET button (RESET [+])
- ⑦ Connection (plug M8, 3-pole)

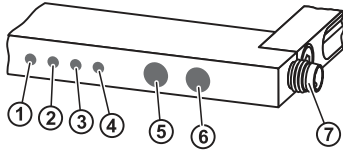

• Operation

The operating elements are the buttons PROGRAM ⑤ and RESET ⑥. It is differentiated between long keypress (>2 seconds) and short keypress (<1 second).

	PROGRAM button	RESET button
reduce transmit power / sensitivity	short keypress	
raise transmit power / sensitivity		short keypress
select program mode	long keypress	
make reset		long keypress
select communication mode	long keypress	long keypress
Program mode (power on display lights red)		
change program level	long keypress	
choose setting	short keypress	short keypress
leave program mode		long keypress
Communication mode (alarm and power on display flashes red)		
leaving communication mode	switch power off	

• Program fork

The programming will be done using the buttons on the fork or with a PC. The fork has the following factory settings: Operation mode = automatic; Switching output = PNP; Pulse stretching = off; Switching behavior = light.

a) program fork with keys

The operation is described here. The color of the switching output ① shows the selected function and the signal and alarm display ② + ③ shows the chosen adjustment.

Overview

Program mode (Power on display ④ = red)	Output display ①
Automatic	⊗ ⊗ ⊗ green
Manual	⊗ ⊗ ⊗ yellow
Teach ignore	⊗ ⊗ ⊗ red

Program level 1-1: Operation mode		
	Signal display ②	Alarm display ③
Automatic	⊗ ⊗ ⊗ green	⊗
Manual	⊗	⊗ ⊗ ⊗ green
Teach ignore	⊗ ⊗ ⊗ green	⊗ ⊗ ⊗ green

Program level 1-2: Switching output type		
	Signal display ②	Alarm display ③
PNP	⊗ ⊗ ⊗ green	⊗
NPN	⊗	⊗ ⊗ ⊗ green
PNP/NPN	⊗ ⊗ ⊗ green	⊗ ⊗ ⊗ green

Program level 1-3: Pulse stretching		
	Signal display ②	Alarm display ③
OFF	⊗	⊗
1 ms	⊗ ⊗ ⊗ green	⊗
10 ms	⊗	⊗ ⊗ ⊗ green
100 ms	⊗ ⊗ ⊗ green	⊗ ⊗ ⊗ green

Program level 1-4: Switching behavior		
	Signal display ②	Alarm display ③
Light switching	⊗ ⊗ ⊗ green	⊗
Dark switching	⊗	⊗ ⊗ ⊗ green

⊗ LED off
⊗ ⊗ ⊗ LED on

Step by step instruction for programming

- Press the PROGRAM button ⑤ long, to enter the program mode.
→ the power on display ④ lights red
- Press the PROGRAM button ⑤ several times until the output display ① shows the color of the required function.
- Press the PROGRAM button ⑤ or RESET button ⑥ short, to select the setting.
- Press the RESET button ⑥ long, to leave the program mode.
→ the power on display ④ lights green

b) program fork with PC

For the communication between the PC and fork, the interface box IFB-1 and the software, WinConnect is required. You will find detailed information about programming with a PC in the operating instructions from the interface box and the WinConnect software.

• Operating procedure

Switch on the power supply. The power on display ④ lights green. The operating mode depends on the selected operation mode.

Automatic

After switching on the supply voltage or after leaving the programm mode the device will reset. The transmit power will be adjusted automatically and the signal display ② lights green when the beam is not interrupted. If the beam is interrupted, the signal display ② is off.

As the optics pollute slowly, the fork will permanently raise the transmit power level. At 95 % of the maximum transmit power, the alarm display ③ lights. The sensitivity can be increased with a short keypress on the RESET button ⑥ and decreased with short keypress on PROGRAM button ⑤.

Manual

The fork must be adjusted to the ambient conditions with the buttons. The transmit power will be raised by pressing the RESET button ⑥ short and reduced by pressing the PROGRAM button ⑤ short. Press the RESET button ⑥ short until the signal display ② is lit constantly. The fork is adjusted to the maximum sensitivity. As the RESET button ⑥ is pressed short once more, the fork will become less sensitive.



Hinweis!

After adjustment of the transmit power, the signal display ② serves as an indicator for the correct adjustment. As the optics slowly polluted, the signal display ② will begin to flash and go out if the optics become contaminated. For the optimal working conditions, the transmit power must be adjusted again or the sensor heads must be cleaned.

Teach ignore

The Fork will be adjusted for an object which is in the light beam during the teach procedure, e.g. package without contents. Pressing the RESET button ⑥ a long time will activate the teach procedure. The transmit power will be adjusted shortly before the switching point. Objects with the same or less optical attenuation will not be detected. The beam can be interrupted by objects with a higher optical attenuation, e.g. package with contents. If the teach procedure is finished, the signal display ② lights. When the teach procedure can not be finished, by the reason that the optical attenuation of the object is too high, the alarm display ③ lights. The switching sensitivity can be increased by a short press of the RESET button ⑥ and decreased by a short press of the PROGRAM button ⑤.

• Switching logic

The switching output ① and the switching output display will switch according to the beam status, see Switching logic.

Beam status	Switching behavior	Switching output type	Output display	Output
	light	PNP	⊗ ⊗ ⊗	+U _B
		NPN	⊗ ⊗ ⊗	0 V
		PNP/NPN	⊗ ⊗ ⊗	+U _B
	dark	PNP	⊗	0 V
		NPN	⊗	+U _B
		PNP/NPN	⊗	0 V
	light	PNP	⊗	0 V
		NPN	⊗	+U _B
		PNP/NPN	⊗	0 V
	dark	PNP	⊗ ⊗ ⊗	+U _B
		NPN	⊗ ⊗ ⊗	0 V
		PNP/NPN	⊗ ⊗ ⊗	+U _B

• Servicing and troubleshooting

Cleaning of the case and optics

Clean the case or the optics with a soft tissue and a mild cleaner if required. Switch off the device before starting cleaning.

Troubleshooting

If the fork light barrier is not working correctly, check the following points:

Problem	possible reason
Power on display ④ jitters or is not lighting	- No or wrong supply voltage. - Device is not correctly connected.
Signal display ② jitters or is not lighting	- Transmit power / Sensitivity is not adjusted correctly. - The beam is interrupted. - The reflector is not mounted correctly. - The optics are contaminated.
Buttons ⑤ + ⑥ without function	- Keylock is active (see operating instruction WinConnect software).

• Dimensions (in mm)

FSx-085V060-...

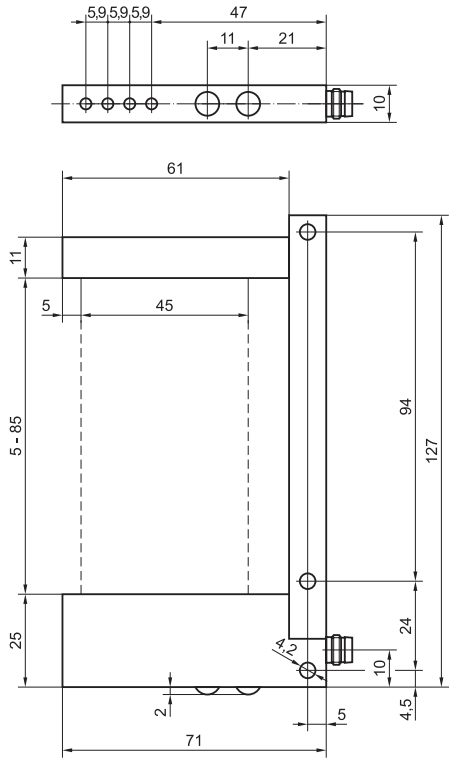

FSx-085V090-...

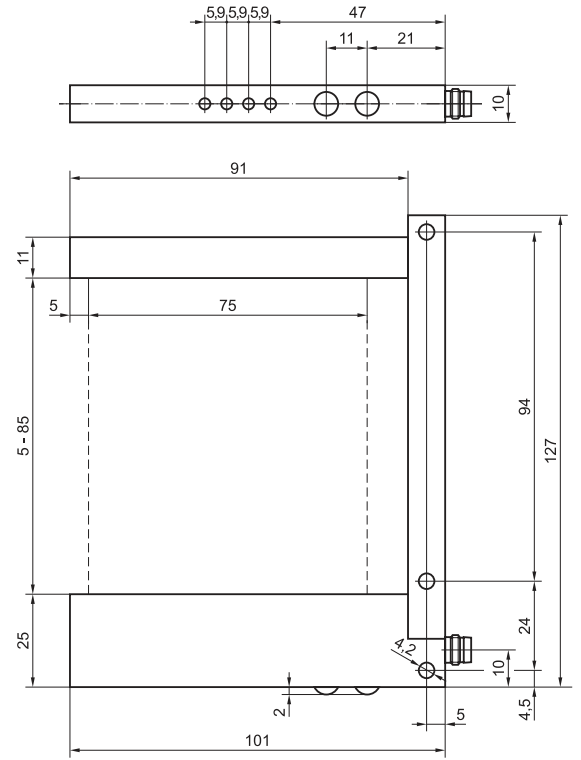

FSx-145V060-...

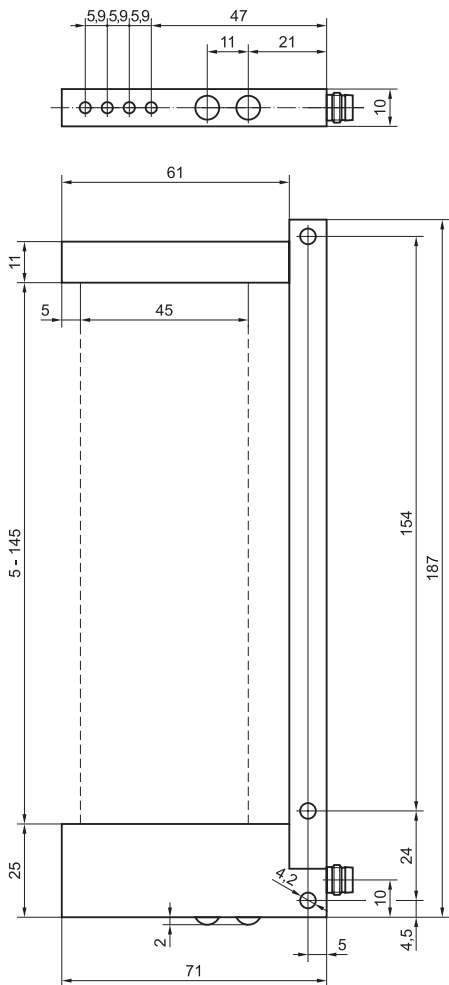

FSx-145V090-...

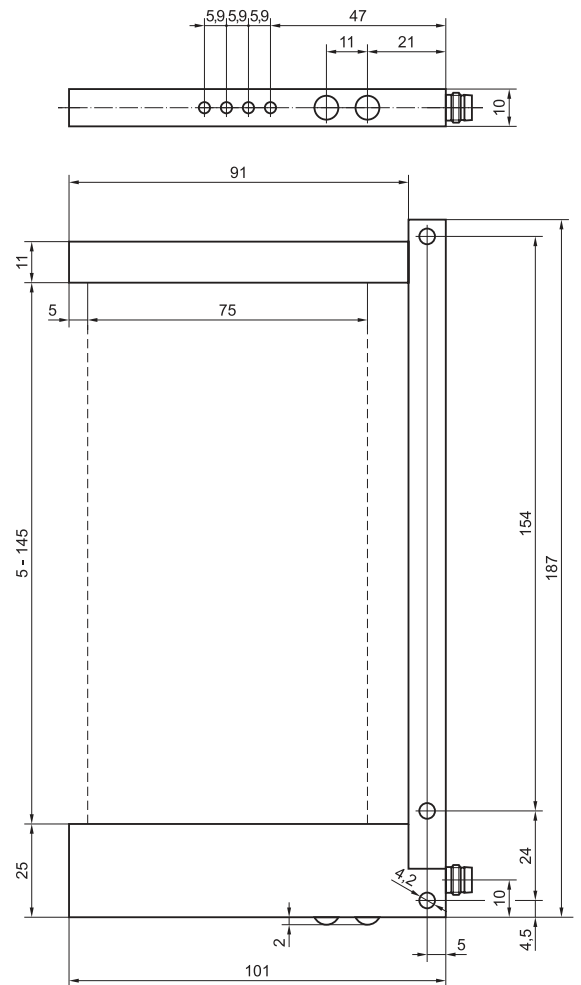

O1141001EN - 10/2014