

IMX-N24...

Features

- Light barrier with modulated IR-Light
- 2-channel installation system for tight assembly without cross talk
- Range up to 50 m (164 ft)
- One relay output (normally open) per channel
- Sensitivity for each channel adjustable with potentiometer
- Programmable light / dark function
- System power 20% / 100% selectable by bit switch
- Multiplex-speed 16 ms / 8 ms switchable
- Transmitter and receiver terminals are short circuit proof
- 11-pin DIN railmounting socket for simple installation

Ordering Table

Supply voltage	Order code
230 V AC	IMX-N24/230VAC
115 V AC	IMX-N24/115VAC
24 V AC	IMX-N24/24VAC
24 V DC	IMX-N24/24VDC
Accessories	Order code
11-pin DIN mounting socket	ISO1
Protective enclosure	PanBox 1x2
Retaining clip	RTC11

Safety Instructions



Warning!

The infrared light barriers IMX-... are not safety systems and should not be used as such systems. The devices are not to be used for applications, where personal safety is dependent on their function.

Short Description

On the 2-channel multiplexer with manual gain setting can work up to two sensor heads (transmitter and receiver) without the possibility of cross talk.

The multiplexer has one relay output (normally open contact) and a yellow status LED for each channel.

Different working conditions can be selected, according to the application, for each channel on the back side of the device by easy accessible DIP-switches.

Consequently, the user is able to change the sensitivity value, which is adjusted to needed range and pollution, for increasing the fine adjustment of the potentiometer or to optimize the object recognition.

Infrared transmitters and receivers in different, compact and robust designs are described in the sensor heads datasheet.



Device Overview

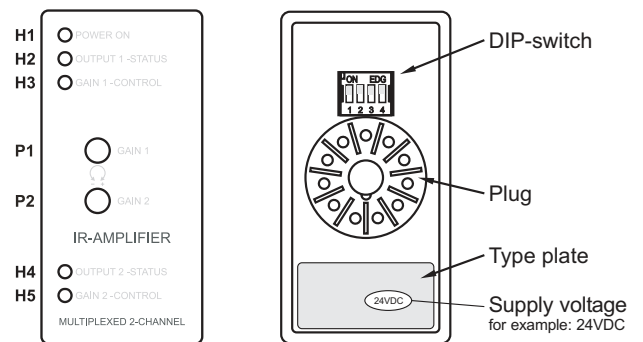

Displays and operating elements

- H1 – Power ON display (green)
- H2 – Output status indicator channel 1 (yellow)
- H3 – Sensitivity indicator channel 1 (green)
- H4 – Output status indicator channel 2 (yellow)
- H5 – Sensitivity indicator channel 2 (green)
- P1 – Gain setting channel 1
- P2 – Gain setting channel 2

DIP-switch setting

DIP-switch	1	2	3	4
	switching function channel 1		switching function channel 2	
	dark	ON	dark	ON
	light	OFF	light	OFF
	100 %	ON	16 ms	ON
	20 %	OFF	8 ms	OFF

Factory setting is marked in dark grey

Switching logic

Beam status	Switching mode	Output status	
		Indicator H2 / H4	Relay output
	light	⊗	—●—
	dark	⊗	—○—
	light	⊗	—○—
	dark	⊗	—●—

IMX-N24...

Technical Data (at 20 °C / 68 °F)

Supply voltage ...AC	230/115/24 V AC / ±10%	
Supply voltage ...DC	24 V DC / ± 10%	
Power consumption (max.)	...AC: 4,4 VA	...DC: 2,3 W
Power loss (max.) (EN 61439)	...230VAC : 3,6 W	...24VDC: 2,3 W
	...115VAC : 3,6 W	
	...24VAC : 3,6 W	
max. Range (through beam)	Receiver IRL-...	Receiver IR-..., IRH-...
Transmitter IT-..., ITL-...	10 m (33 ft)	20 m (66 ft)
Transmitter IT-...HP, ITH-...	15 m (49 ft)	30 m (98 ft)
Transmitter ITA-...	25 m (82 ft)	50 m (164 ft)
Operating basis	modulated IR-light	
Transmit frequency	4,0 kHz	
System power	manual	
Switching behavior	light / dark	
Basic transmit level	20% / 100%	
Switching delay	—	

Multiplex speed low / high	16 ms (62 Hz) / 8 ms (125 Hz)
Relay output	1 normally open contact
Switching data (max.)	5A / 230 V AC (24 V DC)
Reaction time T _{ON} / T _{OFF}	16 ms / 16 ms
Switching frequency (max.)	31 Hz
Transistor output	—
Alarm output	—
Test input	—
MTBF (EN/IEC 61709)	2,2 · 10 ⁶ h (T _{ambient} = 40 °C / 104 °F)
Operating temperature	-25 °C ... 60 °C (-13 °F ... 140 °F)
Storage temperature	-40 °C ... 80 °C (-40 °F ... 176 °F)
Housing material	Plastic
Housing protection	IP 40
Mounting	11-pin DIN socket
Mounting orientation	free
Dimensions	40,0 x 76,5 x 78,5 mm

Connection Diagram



Before connecting the amplifier, look on the type plate and check if the power supply is the same as the connection value. Other values can impair the unit functions or destroy the amplifier.

Caution! The AC-supply devices are isolated from main. A grounded connection on the low voltage side is required (PIN 7).

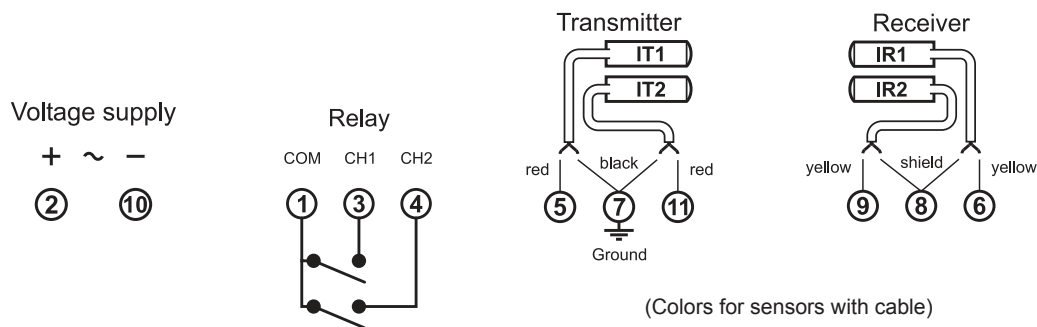

Dimensions (in mm)

