

ISG-A144

Features

- Amplifier with modulated infrared light
- Range up to 50 m (164 ft)
- High immunity to ambient light and interference from other light barriers
- Automatic Level Control (ALC) according to assembly distance and direction
- Test function to check installation and signal strength
- Teach mode for programmable object detection
- Programmable light/dark function
- Two basic transmit levels
- Transmission channel frequency selection by dip-switch
- Test input
- Relay output (1 changeover)
- Transmitter and receiver connections are short-circuit proof
- 11-pin DIN rail mounting socket for simple installation

Ordering Table

| Supply voltage | Order code |
|----------------|-----------------|
| 230 V AC | ISG-A144/230VAC |
| 115 V AC | ISG-A144/115VAC |
| 24 V AC | ISG-A144/24VAC |
| 24 V DC | ISG-A144/24VDC |

| Accessories | Order code |
|----------------------------|------------|
| 11-pin DIN mounting socket | ISO1 |
| Protective enclosure | PanBox 1x1 |
| Retaining clip | RTC11 |

Safety Instructions



The infrared light barriers ISG-... are not safety systems and should not be used as such systems. The devices are not to be used for applications, where personal safety is dependent on their function.

Short Description

This 1-channel automatic amplifier has set a new standard for devices of this type. It is an amplifier with an integrated analysis unit. The automatic gain setting enables the user to simplify the installation and work.

The amplifier can be switched to the different working conditions by DIP-switches. The sensitivity of the device can be switched to 4 basic transmit levels using the same method. Also, the transmitter power can be increased to optimize object recognition.

A control unit, which can be activated by simply pressing a button, is used to determine malfunctions in the transmitter or the receiver. If nothing is defective, the test function shows the signal quality by flashing an LED from 1 to 10 times. The flashes are proportional to the received signal.

Another feature of the amplifier is the test input which enables a PLC to check the system by switching the transmitter on and off. This allows the user to verify the transistor output functionality.

An alarm display and output, which shows errors and the limit of the transmit power and is connectable with a PLC, enables users to safely work with the photoelectric amplifier.

Infrared transmitters and receivers in different, compact and robust designs are described in the sensor heads datasheet.



Device Overview

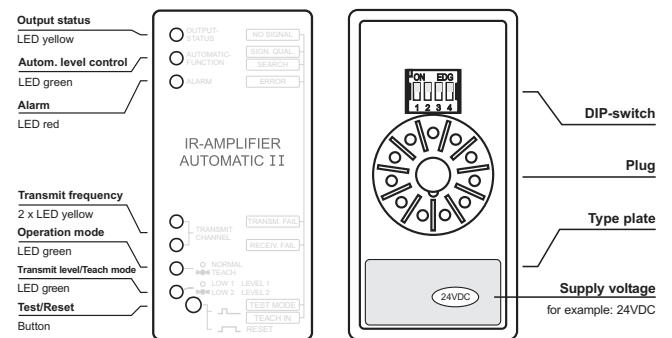

Dip-switch setting

| DIP-switch | 1 | 2 | 3 | 4 |
|------------|----------------|-----------------------------------|----------------|--------------------|
| | Operation mode | Basic transmit level / teach mode | Switching mode | Transmit frequency |
| ON | Teach ON | Level 2 ON Level 1 OFF | dark ON | 4,1 kHz ON |
| OFF | Normal OFF | Low 2 ON Low 1 OFF | light OFF | 3,7 kHz OFF |

Factory setting is marked in dark grey

Switching logic

| Beam status | Switching mode | Output status | |
|-------------|----------------|---------------|------------------|
| | | Indicator | Relay output |
| Light beam | light | Indicator lit | Relay output 1-4 |
| Dark beam | dark | Indicator off | Relay output 1-4 |
| Light beam | light | Indicator off | Relay output 1-4 |
| Dark beam | dark | Indicator lit | Relay output 1-4 |

Dimensions (in mm)

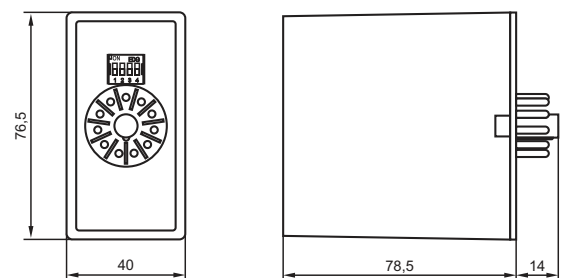

ISG-A144

Technical Data (at 20 °C / 68 °F)

| | | |
|---------------------------------|------------------------|--------------------------|
| Supply voltage ...AC | 230/115/24 V AC / ±10% | |
| Supply voltage ...DC | 24 V DC / ±10% | |
| Power consumption (max.) | ...AC: 4,1 VA | ...DC: 1,9 W |
| Power loss (max.) (EN 61439) | ...230VAC : 3,4 W | ...24VDC: 1,9 W |
| | ...115VAC : 3,4 W | |
| | ...24VAC : 3,2 W | |
| max. Range (through beam) | | |
| | Receiver IRL-... | Receiver IR-..., IRH-... |
| Transmitter IT-..., ITL-... | 7 m (23 ft) | 15 m (49 ft) |
| Transmitter IT-...HP, ITH-... | 12 m (39 ft) | 25 m (82 ft) |
| Transmitter ITA-... | 20 m (66 ft) | 50 m (164 ft) |
| Operating basis | | |
| | modulated IR-light | |
| Transmit frequency (kHz) | 3,7 / 4,1 | |
| System power | automatic | |
| Basic transmit level | Low1 / Low2 | |
| Switching behavior | light / dark | |
| Switching delay | — | |
| ALC delay | — | |

| | |
|--|---|
| Relay output | 1 change over |
| Switching data (max.) | 5A / 230 V AC (24 V DC) |
| Reaction time T _{ON} / T _{OFF} | 25 ms / 25 ms |
| Transistor output | — |
| Alarm output | pnp |
| Switching data (max.) ...AC | 24 V DC / 5 mA |
| Switching data (max.) ...DC | 24 V DC / 100 mA |
| Test input | 0 ... 30 V DC |
| MTBF (EN/IEC 61709) | 2,7 · 10 ⁶ h (T _{ambient} = 40 °C / 104 °F) |
| Operating temperature | -25 ... 60 °C (-13 ... 140 °F) |
| Storage temperature | -40 ... 80 °C (-40 ... 176 °F) |
| Mounting orientation | see below |
| Housing material | Plastic |
| Housing protection | IP 40 |
| Mounting | 11-pin DIN socket |
| Dimensions (mm) | 40 x 76,5 x 78,5 |

Connection Diagram



Before connecting the amplifier, look on the type plate and check if the power supply is the same as the connection value. Other values can impair the unit functions or destroy the amplifier.

Caution! The AC-supply devices are isolated from main. A grounded connection on the low voltage side is required (PIN 7).

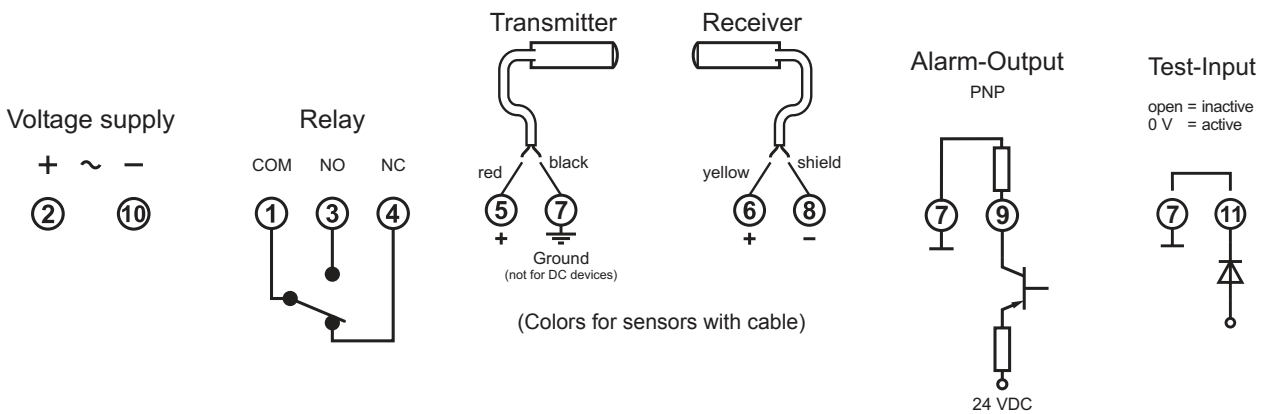

Mounting orientation



For optimum heat dissipation there are ventilation slots in the housing. Ventilation slots must be clean and opened.

Caution! Maintain the minimum distances (see picture 3: Distances).

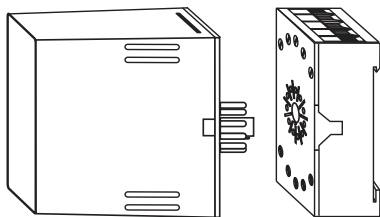

picture 1: Vertical mounting orientation, ventilation slots right

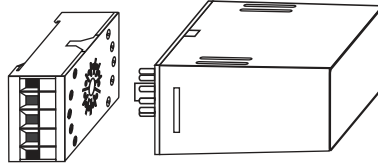

picture 2: Horizontal mounting orientation, ventilation slots top

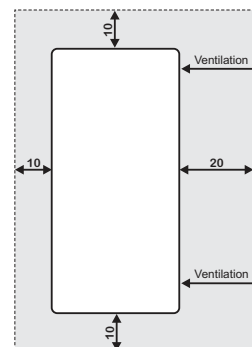

picture 3: Distances (mm)