

## ISG-N138...

### Features

- Amplifier with modulated infrared light
- Range up to 55 m (181 ft)
- Automatically check of the sensor heads
- Sensitivity adjustable with potentiometer
- Switching mode light/dark switchable
- Basic transmit power 20%/100% switchable
- 4 different selectable transmit frequencies
- Adjustable switching-on and switching-off delay
- Relay output (1 change over)
- Transistor output (npn)
- Alarm output
- Transmitter and receiver connections are short-circuit proof
- 11-pin DIN rail mounting socket for simple installation

### Ordering Table

Supply voltage	Order code
230 V AC	ISG-N138/230VAC
115 V AC	ISG-N138/115VAC
24 V AC	ISG-N138/24VAC
24 V DC	ISG-N138/24VDC

Accessories	Order code
11-pin DIN mounting socket	ISO1
Protective enclosure	PanBox 1x1
Retaining clip	RTC11

### Safety Instructions



#### Warning!

The infrared light barriers ISG-... are not safety systems and should not be used as such systems. The devices are not to be used for applications, where personal safety is dependent on their function.

### Short Description

This 1-channel photo-electric amplifier is a processor controlled amplifier with an integrated analysis and sensor head control unit. The photoelectric amplifier works with modulated infrared light, which enables a high degree of immunity to ambient light and cross talk from neighbouring photo-sensors. The manual gain setting, adjusted with a potentiometer located on the front side, enables the user to simplify the installation and work.

According to the application the amplifier can be switched to the different working conditions by DIP-switches. Thus, the user can switch to different basic transmit levels, which selected according to the range and the pollution level, to increase the fine adjustment of the sensitivity. Thus, the object recognition can be optimize.

For the error detection at the sensor heads there is a permanent active sensor control unit. This unit shows the user, if an error is at the transmitter or at the receiver.

An alarm display and output, which shows errors and the limit of the transmit power and is connectable with a PLC, enables users to safely work with the photoelectric amplifier.

Infrared transmitters and receivers in different, compact and robust designs are described in the sensor heads datasheet.



### Device Overview

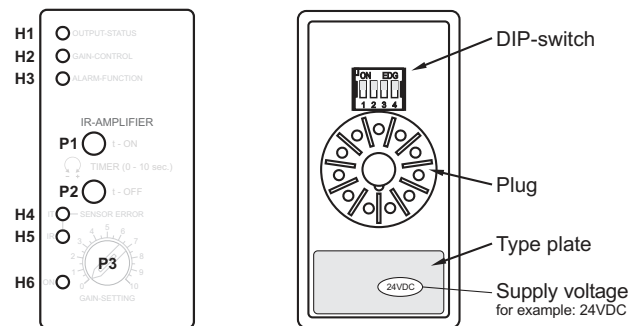

### Displays and operating elements

- H1 – Output status indicator (yellow)
- H2 – Sensitivity indicator (green)
- H3 – Alarm display (red)
- H4 – Transmitter error display (red)
- H5 – Receiver error display (red)
- H6 – Power ON display (green)
- P1 – Switching-on delay
- P2 – Switching-off delay
- P3 – Gain setting

DIP-switch	1	2	3	4
	System power		Transmit frequency	
	20 %	dark	3,0 kHz	ON ON
	100 %	light	3,3 kHz	OFF ON
			3,7 kHz	ON OFF
			4,0 kHz	OFF OFF

Factory setting is marked in dark grey

### Switching logic

Beam status	Switching mode	Output status		
		Indicator H1	Relay output	Transistor output
	light			0 V
	dark			open
	light			open
	dark			0 V

## ISG-N138...

### Technical Data (at 20 °C / 68 °F)

Supply voltage ...AC	230/115/24 V AC / ±10%	
Supply voltage ...DC	24 V DC / ±20%	
Power consumption (max.)	...AC: 3,8 VA	...DC: 1,5 W
Power loss (max.) (EN 61439)	...230VAC : 2,9 W ...115VAC : 2,7 W ...24VAC : 2,7 W	...24VDC: 1,5 W
max. Range (through beam)	Receiver IRL-...	Receiver IR-..., IRH-...
Transmitter IT-..., ITL-...	10 m (33 ft)	20 m (66 ft)
Transmitter IT-...HP, ITH-...	20 m (66 ft)	35 m (115 ft)
Transmitter ITA-...	35 m (115 ft)	55 m (181 ft)
Operating basis	modulated IR-light	
Transmit frequency (kHz)	3,0 / 3,3 / 3,7 / 4,0	
System power	manual	
Switching behavior	light / dark	
Basic transmit level	20% / 100%	
Switching delay	0 ... 10 s	

Relay output	1 change over
Switching data (max.)	5 A / 230 V AC (24 V DC)
Switching frequency (max.)	35 Hz (20% basic transmit level) 9 Hz (100% basic transmit level)
Transistor output	npn
Switching data (max.)	100 mA (30 V DC)
Switching frequency (max.)	50 Hz (20% basic transmit level) 10 Hz (100% basic transmit level)
Alarm output	npn / pnp (pnp only ...DC types)
Switching data (max.)	100 mA (24 V DC)
Test input	—
MTBF (EN/IEC 61709)	259 a (8760 h/a, 40 °C / 104 °F)
Operating temperature	-25 °C ... 50 °C (-13 °F ... 122 °F)
Storage temperature	-40 °C ... 80 °C (-40 °F ... 176 °F)
Housing material	Plastic
Housing protection	IP 40
Mounting	11-pin DIN socket
Dimensions (mm)	40 x 76,5 x 80,0

### Connection Diagram

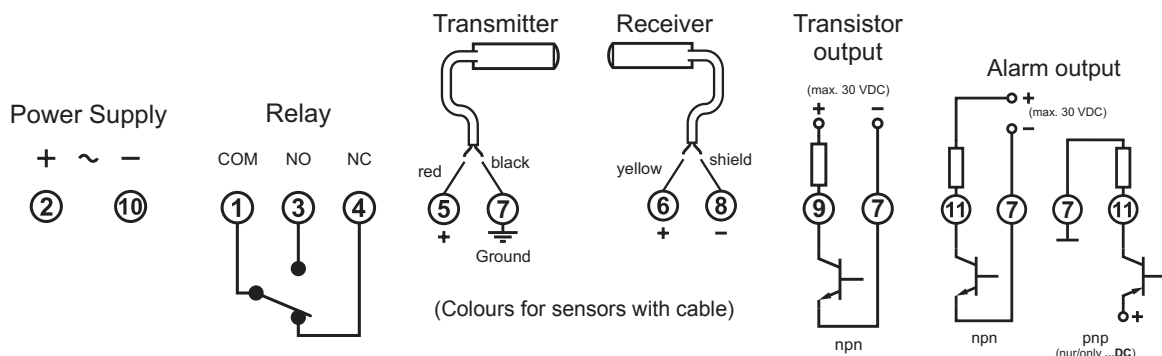

**Caution!**

The AC-supply devices are isolated from main.  
A grounded connection on the low voltage side is required (PIN 7).

### Dimensions (in mm)

