

ISG-N34...

Features

- Amplifier with modulated infrared light
- Range up to 70 m (230 ft)
- high immunity to ambient light and interference from other light barriers
- Sensitivity adjustable with potentiometer
- Adjustable switching-on and switching-off delay
- Switching mode light/dark switchable
- Basic transmit power 20%/100% switchable
- 4 different selectable transmit frequencies
- Test input
- Relay output (changeover)
- Transistor output (npn/pnp)
- Transmitter and receiver connections are short-circuit proof
- 11-pin DIN railmounting socket for simple installation

Ordering Table

Supply voltage	Order code
230 V AC	ISG-N34/230VAC
115 V AC	ISG-N34/115VAC
24 V AC	ISG-N34/24VAC
24 V DC	ISG-N34/24VDC
Accessories	Order code
11-pin DIN mounting socket	ISO1
Protective enclosure	PanBox 1x1
Retaining clip	RTC11

Safety Instructions



Warning!

The infrared light barriers ISG-... are not safety systems and should not be used as such systems. The devices are not to be used for applications, where personal safety is dependent on their function.

Short Description

The 1-channel photoelectric amplifier with manual gain setting is an amplifier with an integrated analysis unit. The amplifier works with modulated infrared light, which enables a high degree of immunity to ambient light and cross talk from neighbouring photo-sensors. The manual gain setting, adjusted with a potentiometer located on the front side, enables the user to simplify the installation and work.

According to the application the amplifier can be switched to the different working conditions by DIP-switches. Thus, the user can switch to different basic transmit levels, which selected according to the range and the pollution level, to increase the fine adjustment of the sensitivity. By this, the object recognition can be optimize. If several sensor heads are mounted side by side, the amplifier works only by different transmit frequencies. Four transmit frequencies are selectable.

Another feature of the amplifier is the test input which enables a PLC to check the system by switching the transmitter on and off. This allows the user to verify the relay or transistor outputs functionality.

Infrared transmitters and receivers in different, compact and robust designs are described in the sensor heads datasheet.



Device Overview

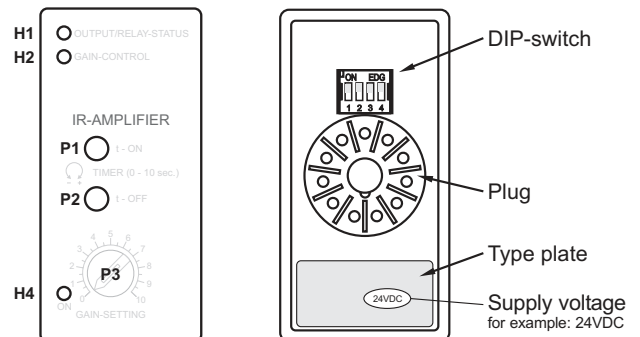

Displays and operating elements

- H1 – Output status indicator (yellow)
- H2 – Sensitivity indicator (green)
- H4 – Power ON display (green)
- P1 – Switching-on delay
- P2 – Switching-off delay
- P3 – Gain setting

DIP-switch	1	2	3	4		
	System power		Switching mode		Transmit frequency	
	20 %	ON	dark	ON	3,5 kHz	ON ON
					3,8 kHz	ON OFF
	100 %	OFF	light	OFF	4,0 kHz	OFF ON
				4,5 kHz	OFF OFF	

Factory setting is marked in dark grey

Switching logic

Beam status	Switching mode	Output status		
		Indicator H1	Relay output	Transistor output
	light	⊗		0 V
	dark	⊗		...AC: 12 VDC ...DC: 24 VDC
	light	⊗		...AC: 12 VDC ...DC: 24 VDC
	dark	⊗		0 V

ISG-N34...

Technical Data (at 20 °C / 68 °F)

Supply voltage ...AC	230/115/24 V AC / ±10%	
Supply voltage ...DC	24 V DC / ±20%	
Power consumption (max.)	...AC: 4,2 VA	...DC: 2,0 W
Power loss (max.) (EN 61439)	...230VAC : 3,1 W ...115VAC : 3,0 W ...24VAC : 3,0 W	...24VDC: 2,0 W
max. Range (through beam)	Receiver IRL-...	Receiver IR-..., IRH-...
Transmitter IT-..., ITL-...	20 m (66 ft)	25 m (82 ft)
Transmitter IT-...HP, ITH-...	30 m (98 ft)	35 m (115 ft)
Transmitter ITA-...	50 m (164 ft)	70 m (230 ft)
Operating basis	modulated IR-light	
Transmit frequency (kHz)	3,5 / 3,8 / 4,0 / 4,5	
System power	manual	
Basic transmit level	20% / 100%	
Switching behavior	light / dark	
Switching delay	0 ... 10 s	

Relay output	1 change over
Switching data (max.)	5A / 230 V AC (24 V DC)
Switching frequency (max.)	18 Hz
Transistor output	npn / pnp
Switching data (max.) ...AC	npn: 100 mA (30 V DC) pnp: 5 mA (12 V DC)
Switching data (max.) ...DC	100 mA (30 V DC)
Switching frequency (max.)	30 Hz
Alarm output	—
Test input	0 ... 30 V DC
MTBF (EN/IEC 61709)	312 a (8760 h/a, 40 °C / 104 °F)
Operating temperature	-25 ... 50 °C (-13 ... 122 °F)
Storage temperature	-40 ... 80 °C (-40 ... 176 °F)
Housing material	Plastic
Housing protection	IP 40
Mounting	11-pin DIN socket
Dimensions (mm)	40 x 76,5 x 80,0

Connection Diagram

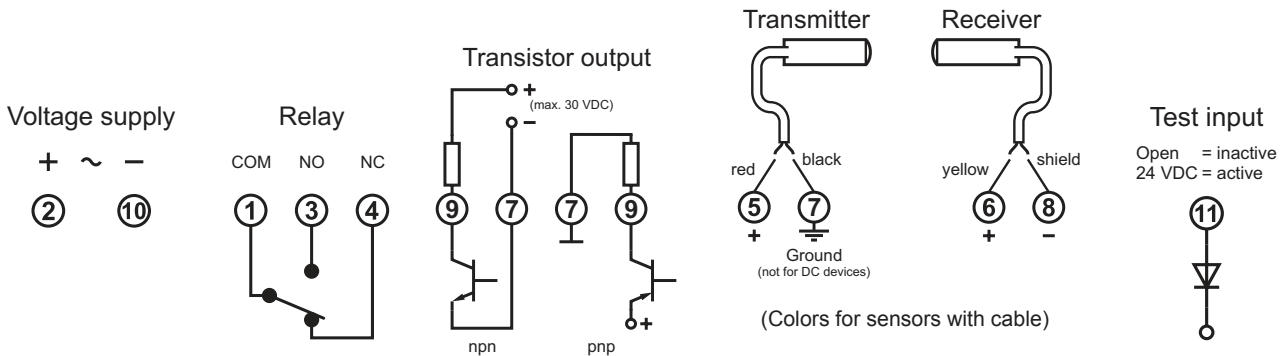

Caution!

The AC-supply devices are isolated from main.
A grounded connection on the low voltage side is required (PIN 7).

Dimensions (in mm)

