

ISM-1220S

Features

- Light barrier with modulated infrared light
- Range up to 55 m
- Manual / automatic operation selectable
- Permanent sensor monitoring
- Test function
- Relay output (1 change over)
- Relay switches delayed or pulsed
- Alarm output
- Test input for external test equipment
- Transmitter and receiver connections are short circuit proof
- Mounting for DIN rail EN 60715

Short Description

The light barrier amplifier ISM series were specially designed for areas with a high range or extreme dirt in which other light barriers reach their limits.

The system includes an amplifier, transmitter IT..., and receiver IR..., and has very high power. Distances up to 55 m are possible. The modulation of the infrared light will additionally give the system a high degree of immunity to ambient light, disturbing impulse and influence from other light barriers.

The amplifier is equipped with an automatic power adjustment, with which the transmit power adjusts to the special environments of the application.

To increase the overall accuracy of the device, permanent sensor monitoring was included, which detects errors at the sensor heads and signals this to the user by the error output. A red LED illuminates to show the error combined with a yellow LED (error transmitter) or a green LED (error receiver).

A relay output gives the light beam status, free or interrupted, to the following evaluation unit, e.g. a PLC. A yellow LED shows this. The output signal can be switched delayed (ON delay or OFF delay) or pulsed (ON pulse or OFF pulse).

Included as extra equipment is the integrated test input with which it is possible to examine the light barrier system's functionality. When the test input is activated, the transmitter will be switched off and the status of the switching output should change.

Infrared transmitters and receivers in different, compact and robust designs are described in the sensor heads datasheet.



Safety Instructions



Warning!

The infrared light barriers ISM-... are not safety systems and should not be used as such systems.

The devices are not to be used for applications, where personal safety is dependent on their function.

Device Overview

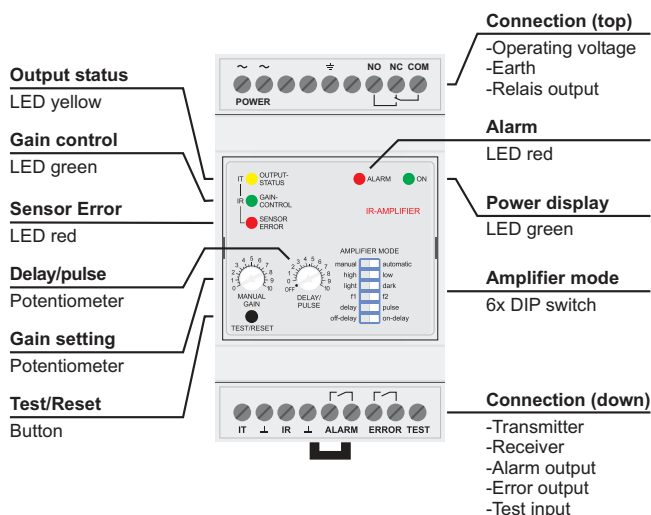

Ordering Table

Operation voltage	Order code
230 V AC	ISM-1220S/230VAC
115 V AC	ISM-1220S/115VAC
24 V AC	ISM-1220S/24VAC
Accessories	
Protective enclosure	PanBox 1x1

ISM-1220S

Technical Data (at 20 °C / 68 °F)

Operating voltage (see type plate)	230 / 115 / 24 V AC / ±10%
Power consumption (max.)	4,8 VA
Power loss (max.) (EN 61439)	not available
Operating basis	modulated infrared light
Transmit frequency [kHz]	3,7 / 4,3
Transmit power	manual / automatic
Basic transmit level	low / high
Switching behavior	light / dark
Multiplex speed	—
Switching delay	0 ... 10 s
MTBF (IEC 61709)	2,0 · 10 ⁶ h (T _a = 40 °C / 104 °F)
Operation temperature	-25 °C ... 50 °C (-13 °F ... 122 °F)
Storage temperature	-40 °C ... 80 °C (-40 °F ... 176 °F)
Housing material	NORYL (self-extinguishing)
Protection class (EN 60529)	IP20
Mounting	top hat rail EN 60715
Electrical connection	screw terminal 0,14 - 2,5 mm ²

Switching output	1 change over	
Switching data (max.)	5 A / 230 V AC (24 V DC)	
max. switching frequency	20 Hz (Low) / 11 Hz (High)	
Alarm output	NO (semiconductor relay) floating distance, short circuit proof	
Switching data (max.)	60 V AC (DC) / 100 mA	
Error output	NO (semiconductor relay) floating distance, short circuit proof	
Switching data (max.)	60 V AC (DC) / 100 mA	
Test input	max. 30 V DC / 2 mA	
response voltage	Low < 5 V DC; High > 15 V DC	
Analog output	—	
COM interface	—	
max. Range (through beam)	Receiver IRL-...	Receiver IR-..., IRH-...
Transmitter IT-..., ITL-...	8 m (26 ft)	20 m (66 ft)
Transmitter IT-...HP, ITH-...	10 m (33 ft)	25 m (82 ft)
Transmitter ITA-...	20 m (66 ft)	55 m (180 ft)

Connection Diagram

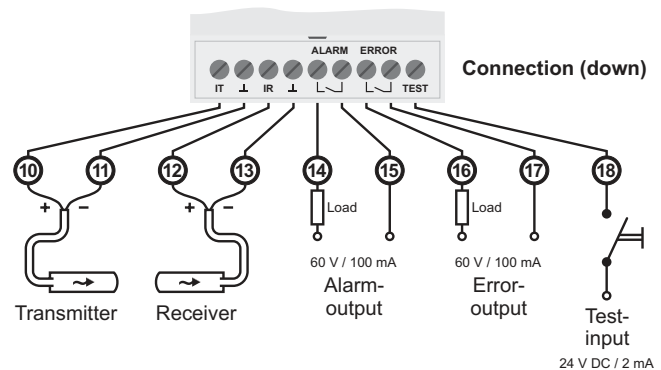
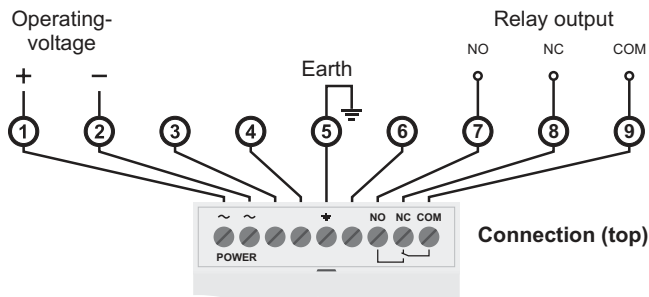

Dimensions (in mm)

