

ISM-2000 / ISM-2000S

Features

- 2-channel multiplex light barrier with modulated infrared light
- High degree of immunity to ambient light, disturbing impulse and influence from other light barriers
- Range up to 55 m
- Manual / automatic operation selectable
- Permanent sensor monitoring
- Test function
- Switching output 60 V / 100 mA, floating distance
- Alarm output for power limit
- Test input for external test equipment
- Sensor connections are short circuit proof
- Mounting for DIN rail EN 60715

Short Description

The light barrier amplifier ISM series were specially designed for areas with a high range or extreme dirt in which other light barriers reach their limits.

The system includes an amplifier, transmitter IT..., and receiver IR..., and has very high power. Distances up to 55 m are possible. The modulation of the infrared light will additionally give the system a high degree of immunity to ambient light, disturbing impulse and influence from other light barriers.

The amplifier is equipped with an automatic power adjustment, with which the transmit power adjusts to the special environments of the application.

To increase the overall accuracy of the device, permanent sensor monitoring was included, which detects errors at the sensor heads and signals this to the user by the alarm output. A red LED illuminates to show the error combined with a yellow LED (error transmitter) or a green LED (error receiver).

A floating distance and short circuit proof switching output give the light beam status, free or interrupted, to the following evaluation unit, e.g. a PLC. A yellow LED shows this.

Included as extra equipment is the integrated test input with which it is possible to examine the light barrier system's functionality. When the test input is activated, the transmitter will be switched off and the status of the switching output should change.

Infrared transmitters and receivers in different, compact and robust designs are described in the sensor heads datasheet.



Safety Instructions



Warning!

The infrared light barriers ISM-... are not safety systems and should not be used as such systems.

The devices are not to be used for applications, where personal safety is dependent on their function.

Device Overview

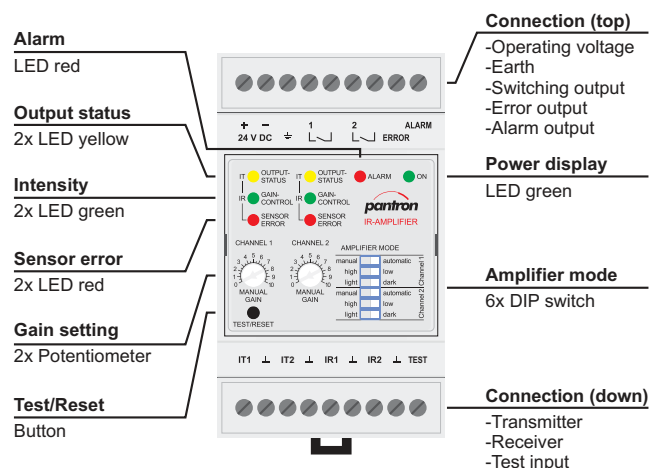

Ordering Table

Type	Order code
ISM-2000 with screw terminals	ISM-2000S/24VDC
ISM-2000 pluggable	ISM-2000/24VDC
Accessories	
Power supply unit 95...265 V AC	PSU-1000S/95-265VAC
Protective enclosure	PanBox 1x2

ISM-2000 / ISM-2000S

Technical Data (at 20 °C / 68 °F, 24 V DC)

Operating voltage	24 V DC / ±20%
Power consumption (max.) ¹	3,6 W
Power loss (max.) ¹ (EN 61439)	not available
Operating basis	modulated infrared light
Transmit frequency	3,9 kHz
Transmit power	manual / automatic
Basic transmit level	low / high
Switching behavior	light / dark
Multiplex speed	8 ms
Switching delay	—
MTBF (IEC 61709)	1,6 · 10 ⁶ h (T _a = 40 °C / 104 °F)
Operation temperature	-25 °C ... 50 °C (-13 °F ... 122 °F)
Storage temperature	-40 °C ... 80 °C (-40 °F ... 176 °F)
Housing material	NORYL (self-extinguishing)
Protection class (EN 60529)	IP20
Mounting	top hat rail EN 60715
Electrical connection	0,14 - 2,5 mm ²
ISM-2000...	pluggable
ISM-2000S...	screw terminal

Switching output	NO (semiconductor relay) floating distance, short circuit proof	
Switching data (max.)	100 mA / 60 V AC (DC)	
Reaction time	24 ms	
Alarm output	pnp, 24 V DC	
current carrying capacity	100 mA	
Error output	pnp, 24 V DC	
current carrying capacity	100 mA	
Analog output	0...10 V DC	
Test input	max. 30 V DC / 2 mA	
response voltage	Low < 5 V DC; High > 15 V DC	
COM interface	—	

max. Range (through beam)	Receiver IRL-...	Receiver IR-..., IRH-...
Transmitter IT-..., ITL-...	8 m (26 ft)	20 m (66 ft)
Transmitter IT-...HP, ITH-...	10 m (33 ft)	30 m (98 ft)
Transmitter ITA-...	20 m (66 ft)	55 m (180 ft)

¹ Without loads at the outputs

Connection Diagram

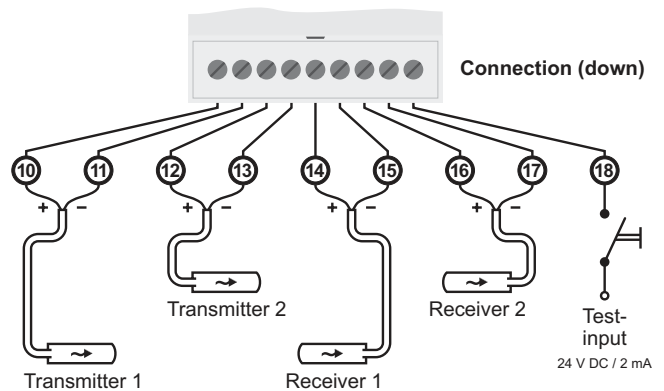
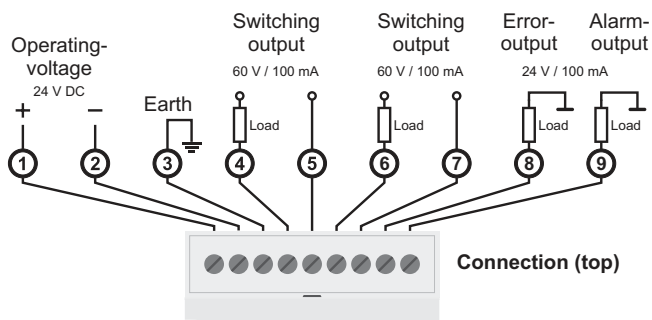

Dimensions (in mm)

ISM-2000

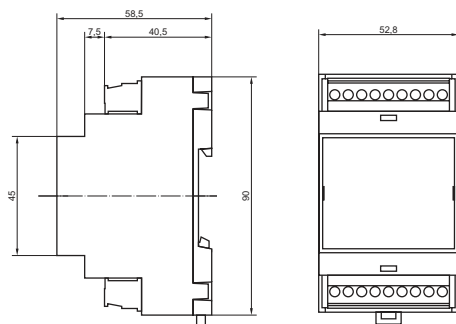

ISM-2000S

